

# LXF Centrifugal Fans

## AC 风机型号说明 Illustration of fan motor model

型号: LXF B 2 E 133 / 42 - P 72 / 15 - 0001  
 TYPE: ① ② ③ ④ ⑤ ⑥ ⑦ ⑧ ⑨ ⑩

- ① LXF-离心风机  
LXF-Centrifugal Fan
- ② B-后倾式, F-前倾式, FG-前倾离心单进风配蜗壳, FD-前倾离心双进风配蜗壳  
B-Backward, F-Forward  
FG-Forward centrifugal single inlet, with volute  
FD-Forward centrifugal dual inlet, with volute
- ③ 电机极数  
Motor poles
- ④ E-单相电容运转, D-三相异步运转  
E-Single phase capacitor operation, D-Three phases asynchronous operation
- ⑤ 叶轮直径  
The diameter of the impeller
- ⑥ 出风口高度  
Air outlet height
- ⑦ P-风轮为塑料材质, M-风轮为金属材质, X-风轮为混合材质  
P-The impeller is made of plastic material, M-Metal, X-Mixture
- ⑧ 转子直径  
The diameter of the rotor
- ⑨ 铁芯叠厚  
The thickness of laminated core
- ⑩ 流水号  
Serial number

## AC 风机接线方式 Wiring diagram

单相 Single phase      三相 Three phase

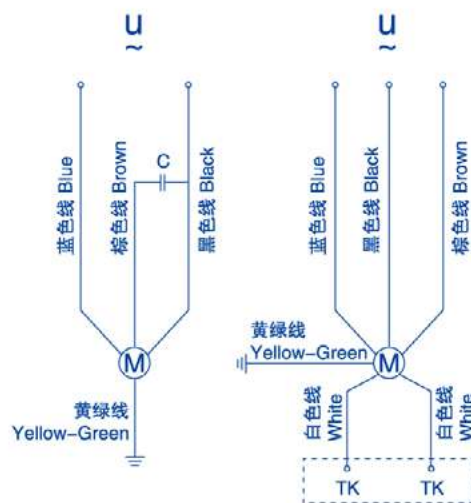

# LXF 交流前倾式离心风机 Forward Centrifugal Fans(AC)

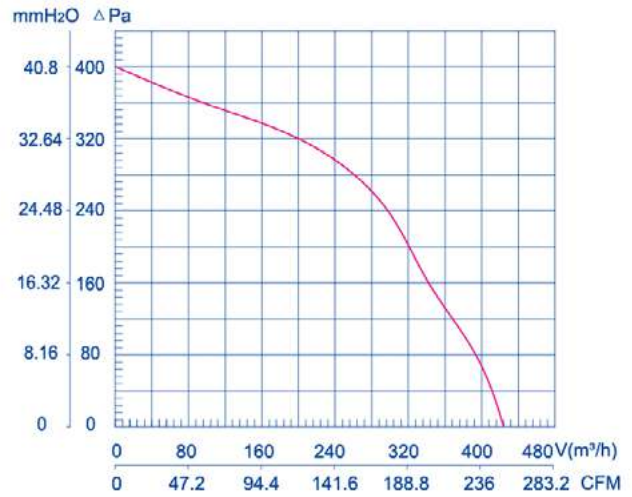

### 使用说明:

工作方式: S1  
 绝缘等级: B级/F级  
 环境温度: -25℃~+60℃  
 防护等级: IP44

### Instructions:

Operation mode: S1  
 Insulation class: B/F  
 Ambient temperature: -25℃~+60℃  
 Type of protection: IP44

Type 型号	Rated voltage 额定电压 V	Frequency 频率 Hz	Current 额定电流 A	Input power 输入功率 W	Rated speed 额定转速 r/min	AIR FLOW 最大风量 m³/h	Capacitance 电容 μF	Noise level 噪音 dBA	Net weight 净重 kg
LXFF2E140/60-P92/35-****	220	50	0.53	110	2500	480	3	67	3.0

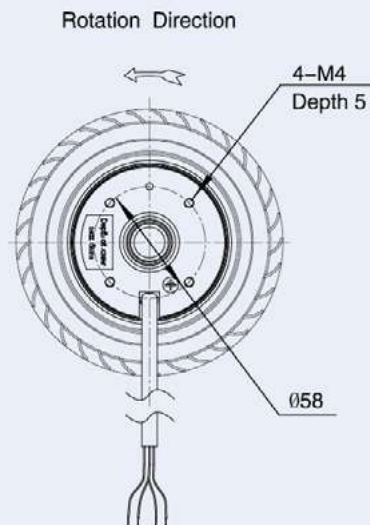
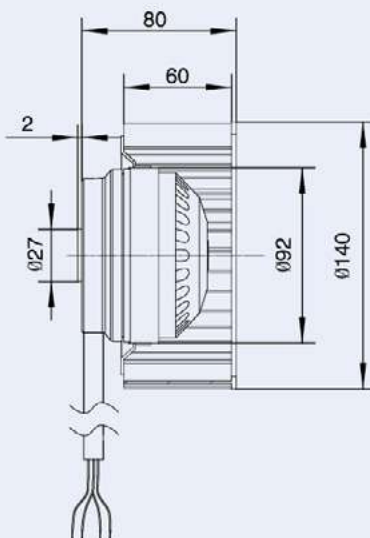

**LXF** 交流前倾式离心风机 **Forward Centrifugal Fans(AC)**

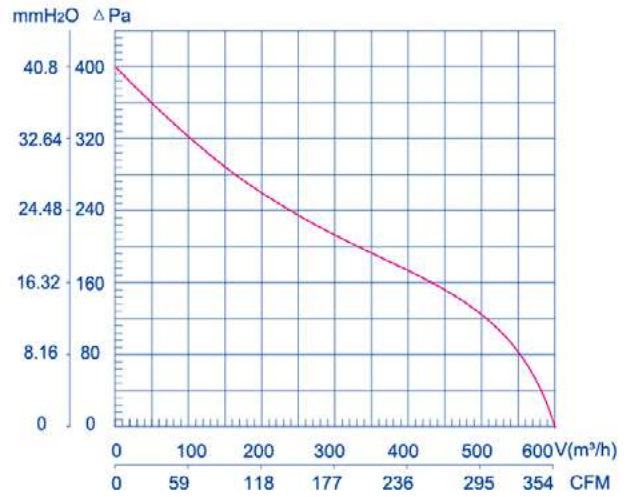

**使用说明:**

工作方式: S1  
绝缘等级: B级/F级  
环境温度: -25℃~+60℃  
防护等级: IP44

**Instructions:**

Operation mode: S1  
Insulation class: B/F  
Ambient temperature: -25℃~+60℃  
Type of protection: IP44

Type 型号	Rated voltage 额定电压 V	Frequency 频率 Hz	Current 额定电流 A	Input power 输入功率 W	Rated speed 额定转速 r/min	AIR FLOW 最大风量 m³/h	Capacitance 电容 μF	Noise level 噪音 dBA	Net weight 净重 kg
LXF6E277/45-P92/35-****	220	50	0.36	80	900	600	3	68	3.0

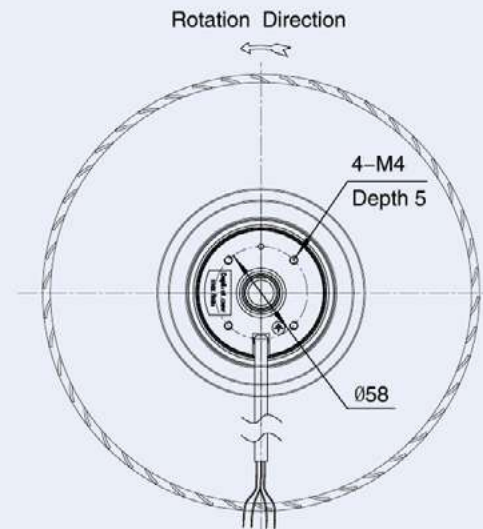
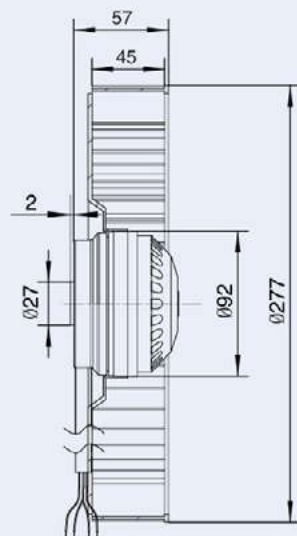

# LXF 交流前倾式离心风机 Forward Centrifugal Fans(AC)

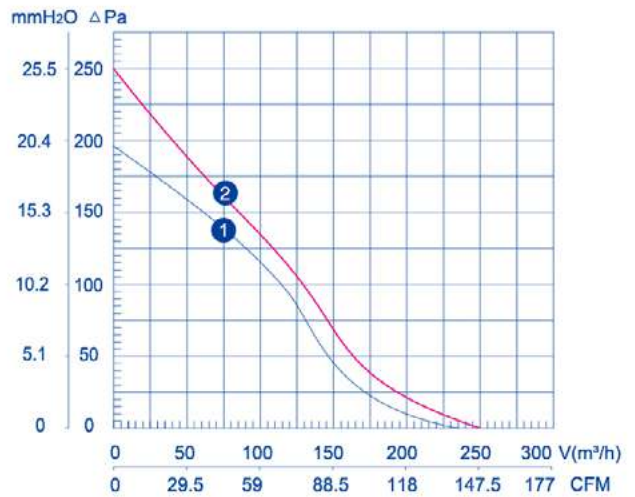

### 使用说明:

工作方式: S1  
 绝缘等级: B级/F级  
 环境温度: -25℃~+60℃  
 防护等级: IP44

### Instructions:

Operation mode: S1  
 Insulation class: B/F  
 Ambient temperature: -25℃~+60℃  
 Type of protection: IP44

Type 型号	Rated voltage 额定电压 V	Frequency 频率 Hz	Current 额定电流 A	Input power 输入功率 W	Rated speed 额定转速 r/min	Air Flow 最大风量 m³/h	Capacitance 电容 μF	Noise level 噪音 dBA	Net weight 净重 kg	Curve 曲线
LXFF2E120/60-M92/15-****	220	50	0.23	51	2400	230	2	45	1.8	①
	110	60	0.51	58	2570	250	6	47	1.8	②

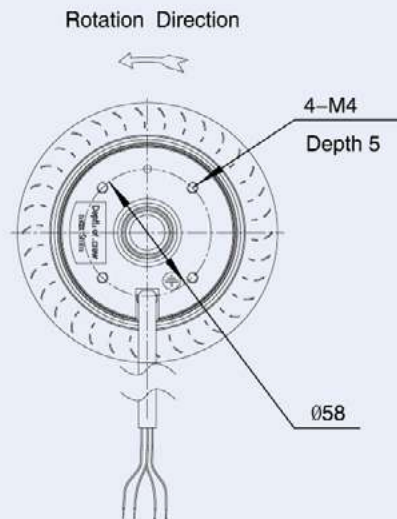
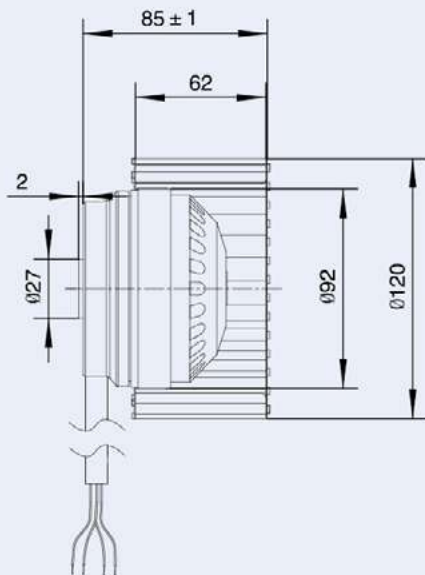

# LXF 交流前倾式离心风机 Forward Centrifugal Fans(AC)

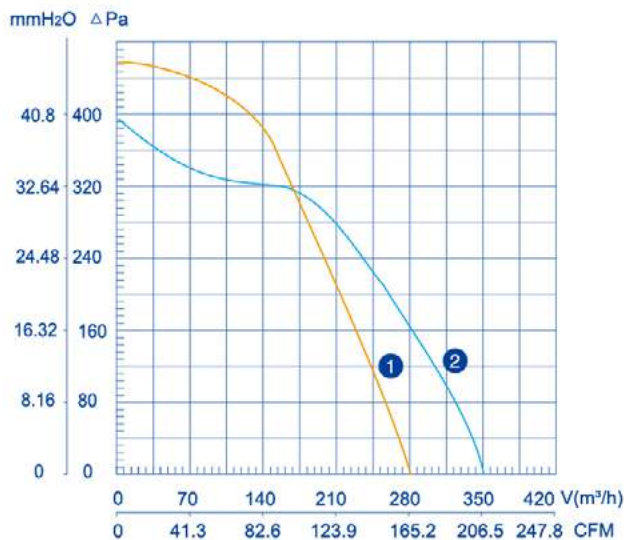

### 使用说明:

工作方式: S1  
绝缘等级: B级/F级  
环境温度: -25℃~+60℃  
防护等级: IP44

### Instructions:

Operation mode: S1  
Insulation class: B/F  
Ambient temperature: -25℃~+60℃  
Type of protection: IP44

Type 型号	Rated voltage 额定电压 V	Frequency 频率 Hz	Current 额定电流 A	Input power 输入功率 W	Rated speed 额定转速 r/min	AIR FLOW 最大风量 m³/h	Capacitance 电容 μF	Noise level 噪音 dBA	Net weight 净重 kg	Curve 曲线
LXFF2E133/50-M92/25-****	220	50	0.40	85	2420	280	3	51	1.8	①
LXFF2E133/73-M92/35-****	220	50	0.47	96	2700	370	3	52	2.0	②

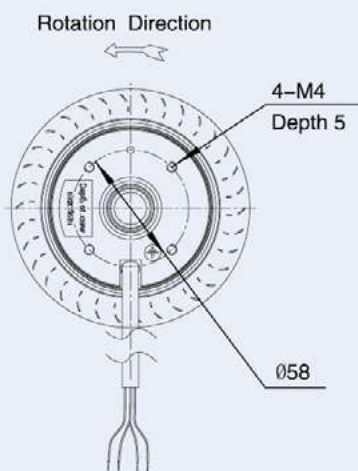
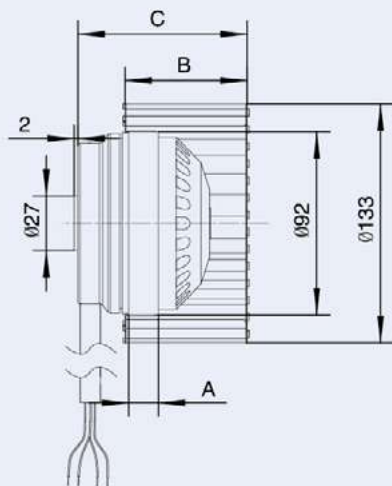

型号 Type	A	B	C
LXFF2E133/50-M92/25-****	25	50	74
LXFF2E133/73-M92/35-****	35	73	97

# LXF 交流前倾式离心风机 Forward Centrifugal Fans(AC)

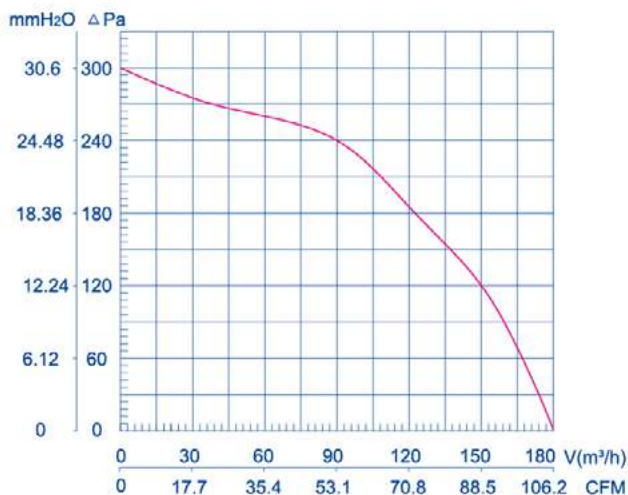

### 使用说明:

工作方式: S1  
 绝缘等级: B级/F级  
 环境温度: -25℃~+60℃  
 防护等级: IP44

### Instructions:

Operation mode: S1  
 Insulation class: B/F  
 Ambient temperature: -25℃~+60℃  
 Type of protection: IP44

Type 型号	Rated voltage 额定电压 V	Frequency 频率 Hz	Current 额定电流 A	Input power 输入功率 W	Rated speed 额定转速 r/min	Air Volume 额定风量 m <sup>3</sup> /h	Capacitance 电容 μF	Noise level 噪声 dBA	Net weight 净重 kg
LXFF2E140/30-M72/15-****	220	50	0.18	38	2000	180	1.5	50	1.5

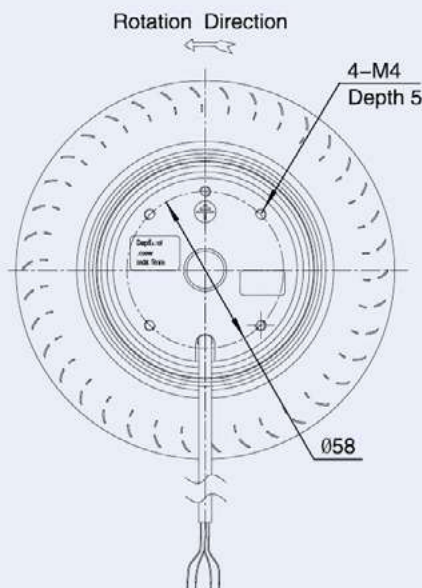
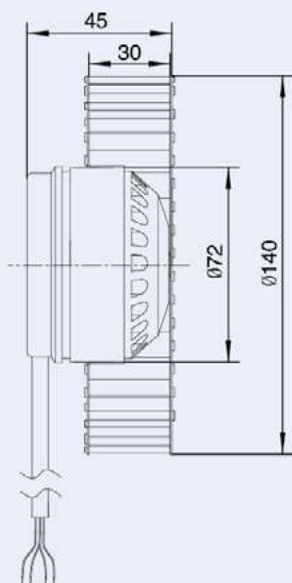

**LXF** 交流前倾式离心风机 **Forward Centrifugal Fans(AC)**

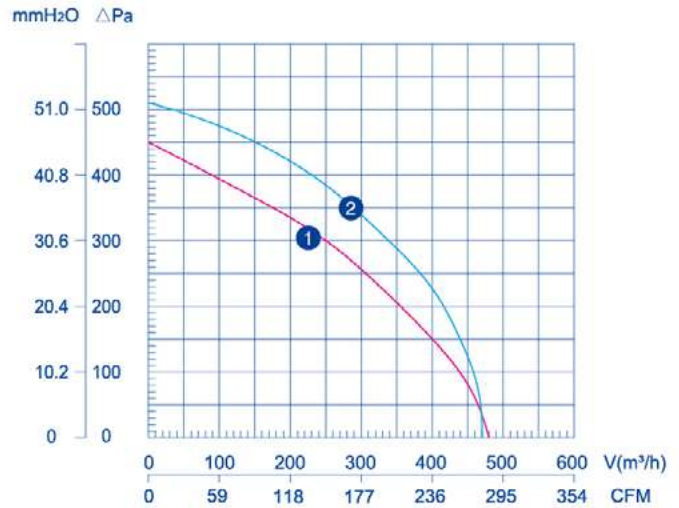

**使用说明:**

工作方式: S1  
绝缘等级: B级/F级  
环境温度: -25℃~+60℃  
防护等级: IP44

**Instructions:**

Operation mode: S1  
Insulation class: B/F  
Ambient temperature: -25℃~+60℃  
Type of protection: IP44

Type 型号	Rated voltage 额定电压 V	Frequency 频率 Hz	Current 额定电流 A	Input power 输入功率 W	Rated speed 额定转速 r/min	AIR FLOW 最大风量 m³/h	Capacitance 电容 μ F	Noise level 噪音 dBA	Net weight 净重 kg	Curve 曲线
LXFF2E140/60-M92/35-****	220	50	0.35	90	2750	480	3	72	3.0	①
	110	60	0.20	150	3200	470	16	75	3.0	②

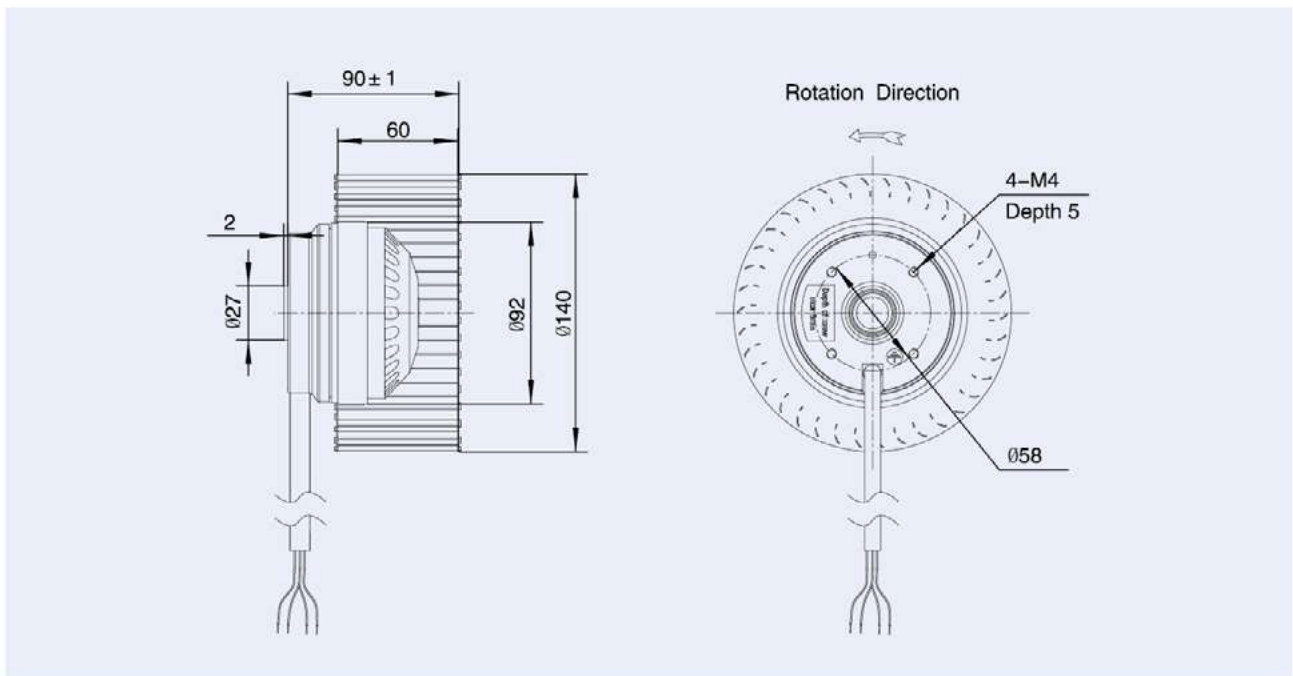

# LXF 交流前倾式离心风机 Forward Centrifugal Fans(AC)

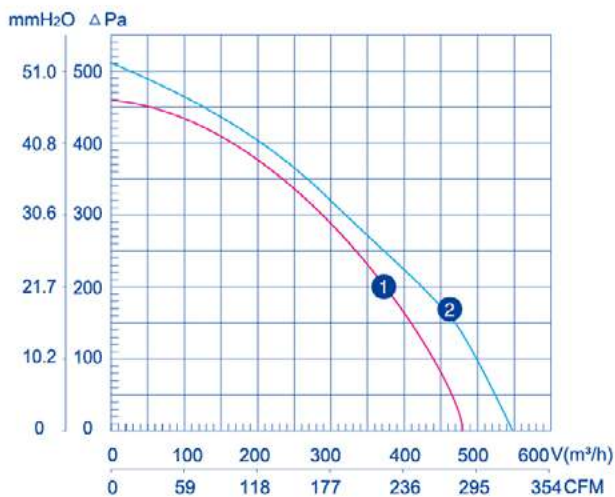

### 使用说明:

工作方式: S1  
 绝缘等级: B级/F级  
 环境温度: -25℃~+60℃  
 防护等级: IP44

### Instructions:

Operation mode: S1  
 Insulation class: B/F  
 Ambient temperature: -25℃~+60℃  
 Type of protection: IP44

Type 型号	Rated voltage 额定电压 V	Frequency 频率 Hz	Current 额定电流 A	Input power 输入功率 W	Rated speed 额定转速 r/min	AIR FLOW 最大风量 m³/h	Capacitance 电容 μF	Noise level 噪音 dBA	Net weight 净重 kg	Curve 曲线
LXFF2E150/70-M92/35-****	220	50	0.55	120	2550	500	3	75	3.0	①
	115	60	1.30	180	2930	550	18	76	3.0	②

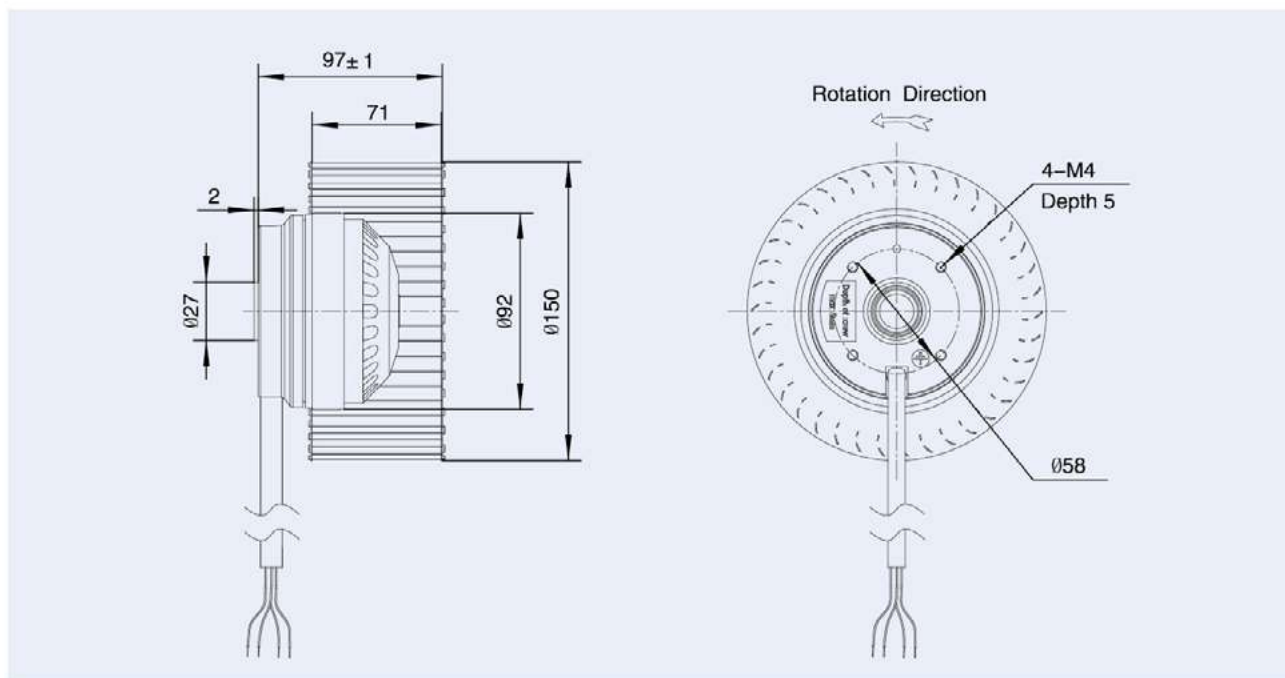



**LXF** 交流前倾式离心风机 **Forward Centrifugal Fans(AC)**

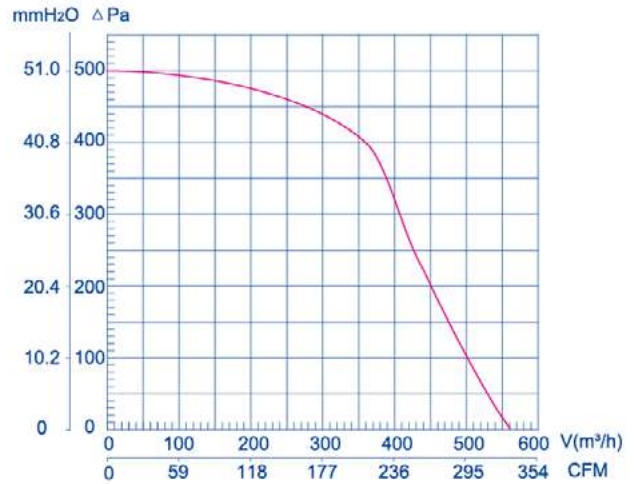

**使用说明:**

工作方式: S1  
绝缘等级: B级/F级  
环境温度: -25℃--+60℃  
防护等级: IP44

**Instructions:**

Operation mode: S1  
Insulation class: B/F  
Ambient temperature: -25℃--+60℃  
Type of protection: IP44

Type 型号	Rated voltage 额定电压 V	Frequency 频率 Hz	Current 额定电流 A	Input power 输入功率 W	Rated speed 额定转速 r/min	AIR FLOW 最大风量 m³/h	Capacitance 电容 μ F	Noise level 噪音 dBA	Net weight 净重 kg
LXFF2E160/60-M92/35-****	220	50	0.65	140	2600	560	4	75	3.5

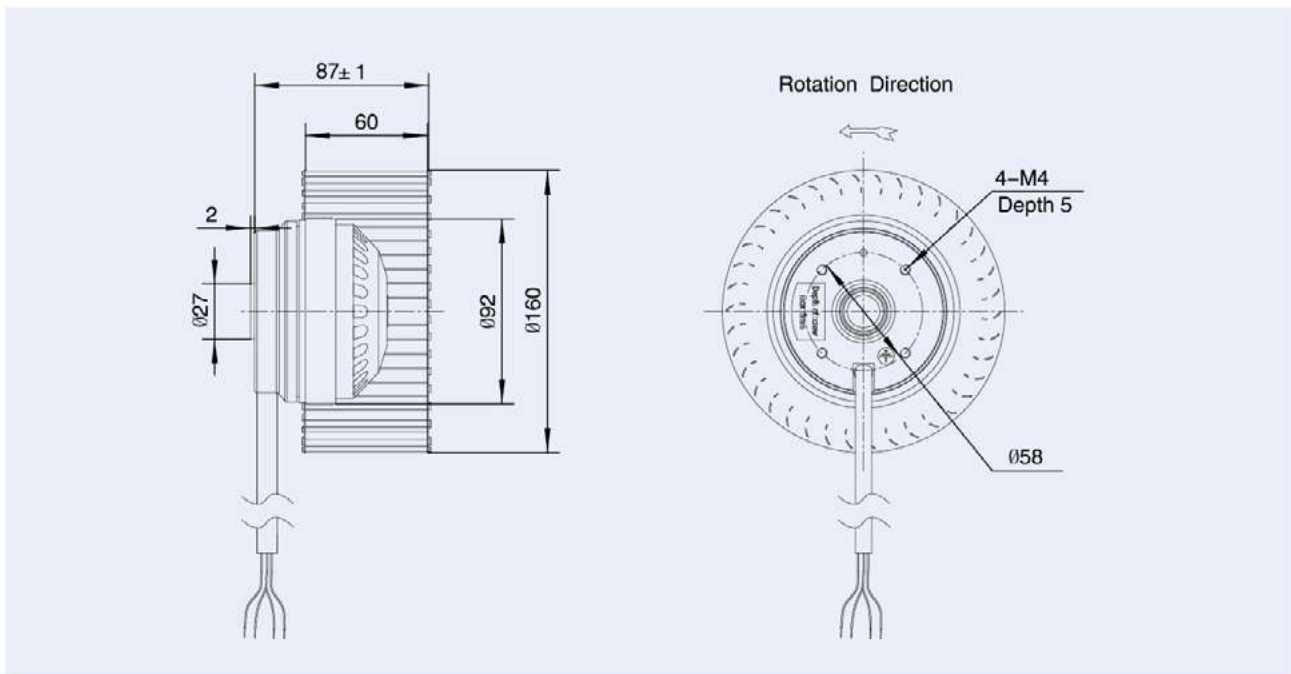

# LXF 交流前倾式离心风机 Forward Centrifugal Fans(AC)

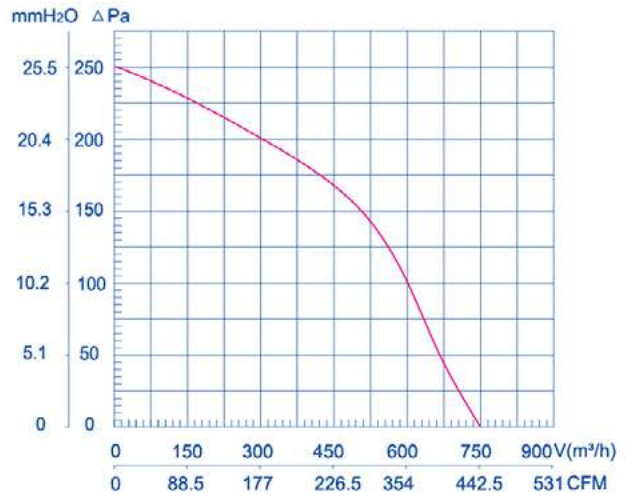

### 使用说明:

工作方式: S1  
 绝缘等级: B级/F级  
 环境温度: -25℃~+60℃  
 防护等级: IP44

### Instructions:

Operation mode: S1  
 Insulation class: B/F  
 Ambient temperature: -25℃~+60℃  
 Type of protection: IP44

Type 型号	Rated voltage 额定电压 V	Frequency 频率 Hz	Current 额定电流 A	Input power 输入功率 W	Rated speed 额定转速 r/min	AIR FLOW 最大风量 m³/h	Capacitance 电容 μF	Noise level 噪音 dBA	Net weight 净重 kg
LXFF4E180/90-M102/34-****	220	50	0.62	100	1450	750	4	57	4.0

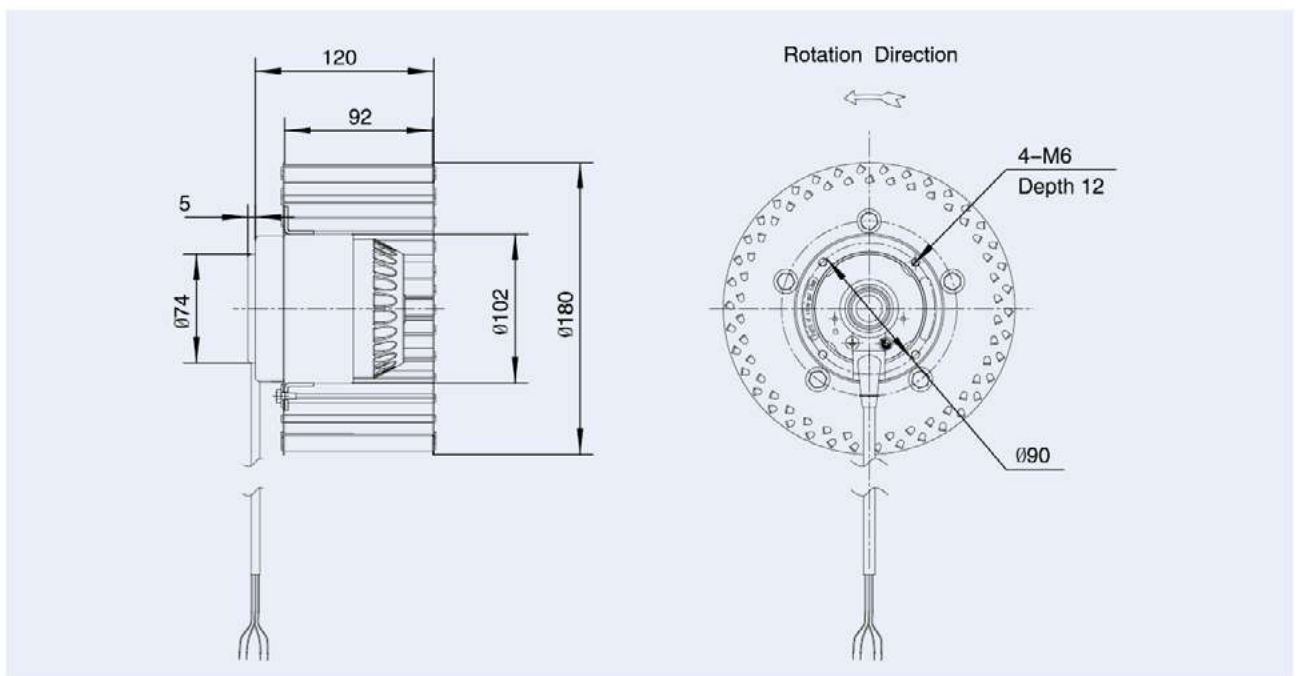

**LXF** 交流前倾式离心风机 **Forward Centrifugal Fans(AC)**

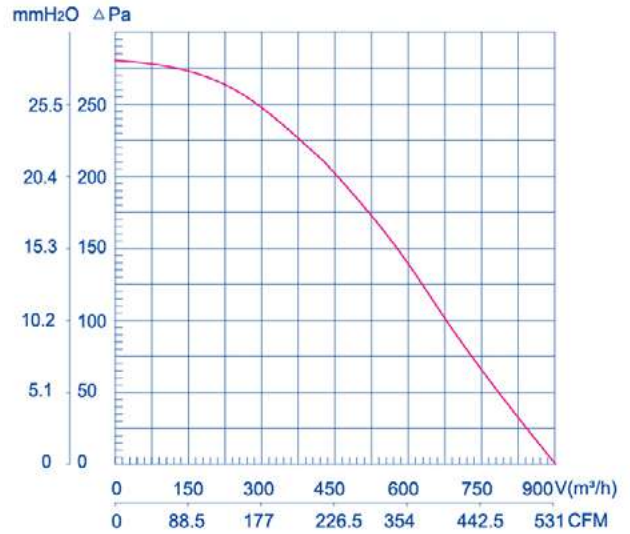

**使用说明:**

工作方式: S1  
绝缘等级: B级/F级  
环境温度: -25℃~+60℃  
防护等级: IP44

**Instructions:**

Operation mode: S1  
Insulation class: B/F  
Ambient temperature: -25℃~+60℃  
Type of protection: IP44

Type 型号	Rated voltage 额定电压 V	Frequency 频率 Hz	Current 额定电流 A	Input power 输入功率 W	Rated speed 额定转速 r/min	AIR FLOW 最大风量 m³/h	Capacitance 电容 μF	Noise level 噪音 dBA	Net weight 净重 kg
LXFF4E200/100-M102/34-****	220	50	0.65	130	1400	900	4	58	4.0

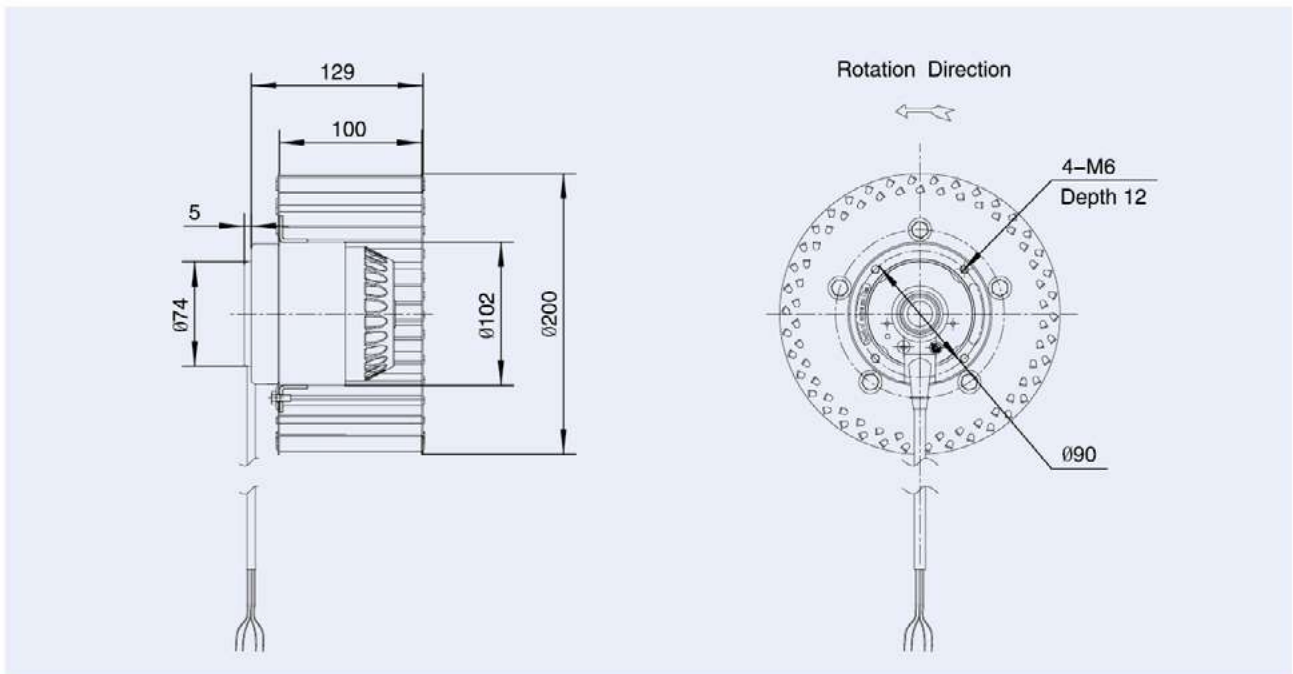

# LXF 双进风离心风机 Dual Inlet Centrifugal Fans (AC)

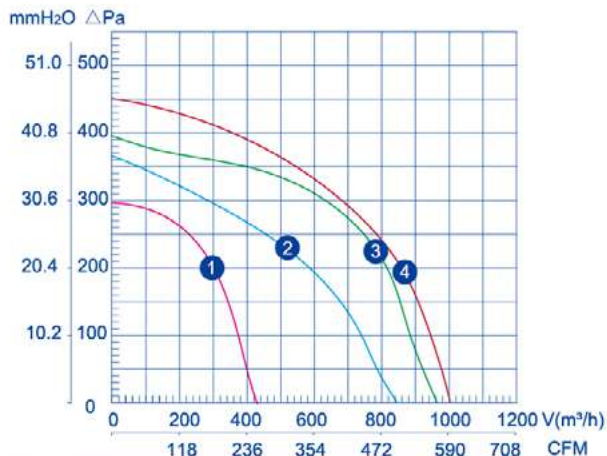

### 使用说明:

工作方式: S1  
 绝缘等级: B级/F级  
 环境温度: -25℃~+60℃  
 防护等级: IP44

### Instructions:

Operation mode: S1  
 Insulation class: B/F  
 Ambient temperature: -25℃~+60℃  
 Type of protection: IP44

Type 型号	Rated voltage 额定电压 V	Frequency 频率 Hz	Current 额定电流 A	Input power 输入功率 W	Rated speed 额定转速 r/min	Air Volume 额定风量 m³/h	Capacitance 电容 μF	Noise level 噪音 dBA	Net weight 净重 kg	Curve 曲线
LXFFG2E120/145-M92/35-****	220	50	0.61	130	2540	480	3	67	3.5	①
LXFFG2E133/215-M92/35-****	220	50	1.09	242	1720	840	6	68	4.0	②
LXFFG2E133/232-M92/45-****	220	50	1.38	300	1800	980	8	70	4.3	③
LXFFG2E146/232-M92/45-****	220	50	1.40	310	1600	1000	8	72	4.5	④

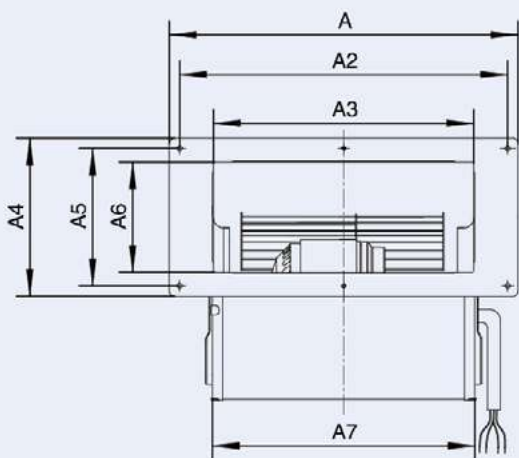

Type	A	A2	A3	A4	A5	A6	A7
120	175	164	138.5	79	47.5	41.5	145
133	254	238	213	108	92	79	216
133-232	309.5	291	231	140.5	122	98	233
146	309.5	291	231	140.5	122	98	233

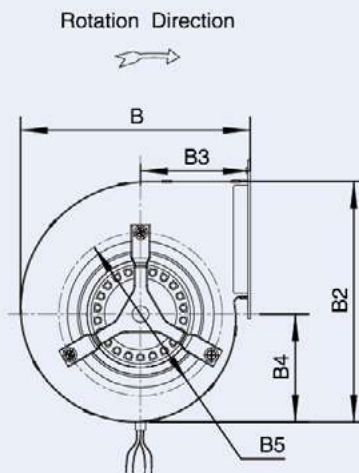

Type	B	B2	B3	B4	B5
120	157	166	75	80	124
133	172	180	89	80.9	144.5
133-232	204	213	97	95.5	144.5
146	204	213	97	95.5	144.5

# LXF 单进风离心风机 Single Inlet Centrifugal Fans (AC)

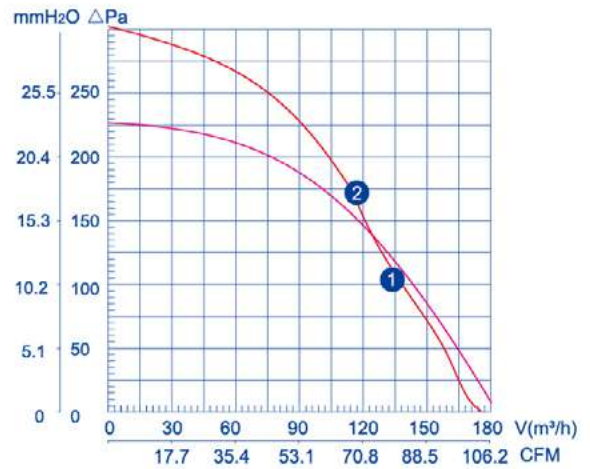

### 使用说明:

工作方式: S1  
 绝缘等级: B级/F级  
 环境温度: -25℃~+60℃  
 防护等级: IP44

### Instructions:

Operation mode: S1  
 Insulation class: B/F  
 Ambient temperature: -25℃~+60℃  
 Type of protection: IP44

Type 型号	Rated voltage 额定电压 V	Frequency 频率 Hz	Current 额定电流 A	Input power 输入功率 W	Rated speed 额定转速 r/min	Air Volume 额定风量 m <sup>3</sup> /h	Capacitance 电容 μF	Noise level 噪音 dBA	Net weight 净重 kg	Curve 曲线
LXFFG108/50-M72/15-****	220	50	0.25	50	2050	185	2	61	1.2	①
LXFFG108/50-M72/15-****	110	60	0.35	35	2350	172	4	62	1.2	②

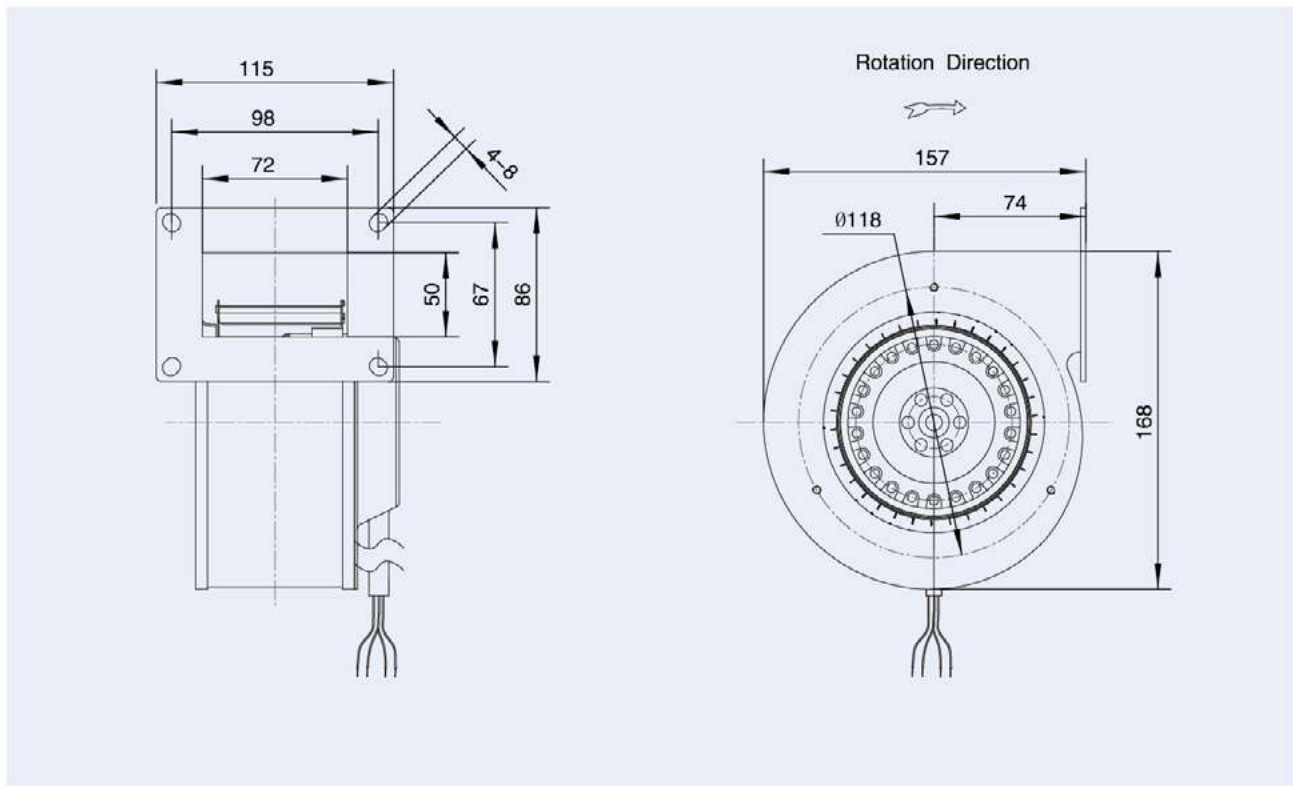

# LXF 单进风离心风机 Single Inlet Centrifugal Fans (AC)

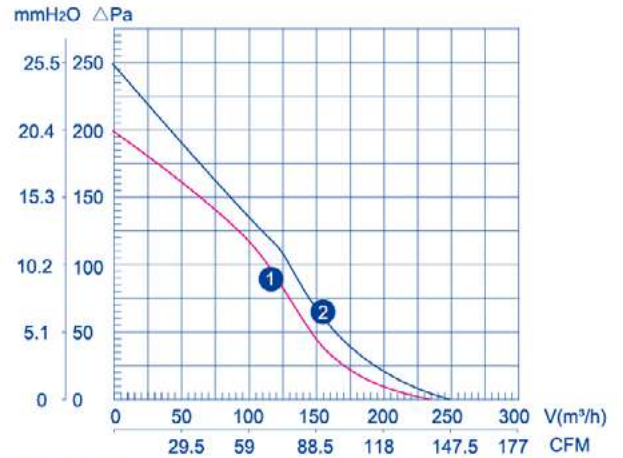

### 使用说明:

工作方式: S1  
 绝缘等级: B级/F级  
 环境温度: -25℃~+60℃  
 防护等级: IP44

### Instructions:

Operation mode: S1  
 Insulation class: B/F  
 Ambient temperature: -25℃~+60℃  
 Type of protection: IP44

Type 型号	Rated voltage 额定电压 V	Frequency 频率 Hz	Current 额定电流 A	Input power 输入功率 W	Rated speed 额定转速 r/min	Air Volume 额定风量 m³/h	Capacitance 电容 μF	Noise level 噪音 dBA	Net weight 净重 kg	Curve 曲线
LXFFG120/60-M92/15-****	220	50	0.23	51	2350	230	2	55	1.8	①
LXFFG120/60-M92/15-****	110	60	0.70	86	2630	250	6	57	1.8	②

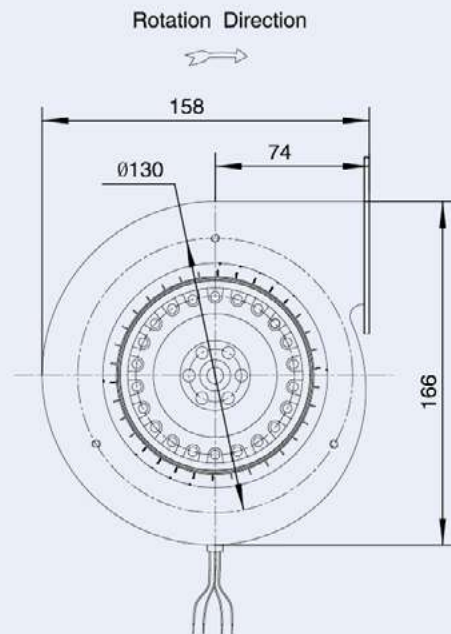
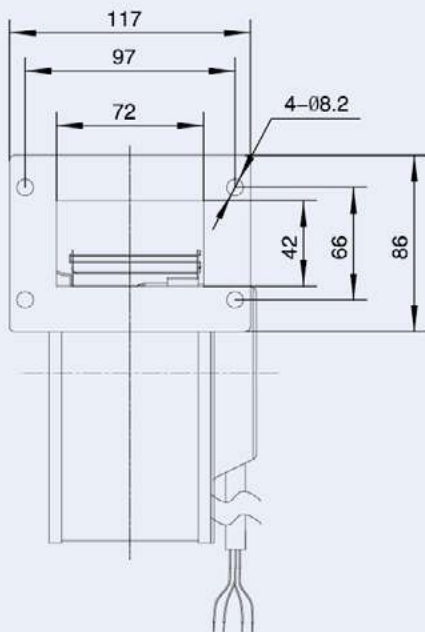

**LXF** 单进风离心风机 **Single Inlet Centrifugal Fans (AC)**

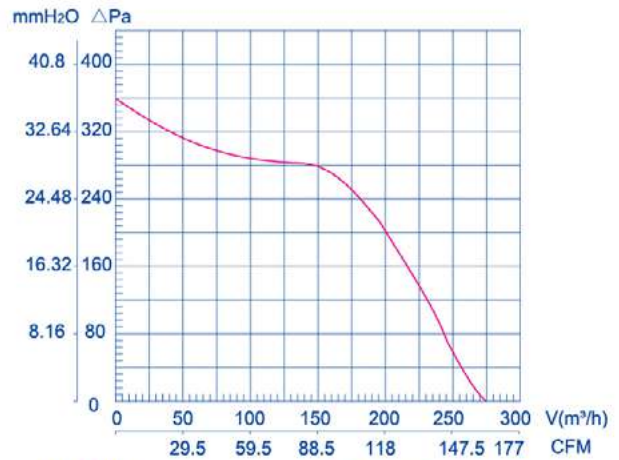

**使用说明:**

工作方式: S1  
绝缘等级: B级/F级  
环境温度: -25℃~+60℃  
防护等级: IP44

**Instructions:**

Operation mode: S1  
Insulation class: B/F  
Ambient temperature: -25℃~+60℃  
Type of protection: IP44

Type 型号	Rated voltage 额定电压 V	Frequency 频率 Hz	Current 额定电流 A	Input power 输入功率 W	Rated speed 额定转速 r/min	Air Volume 额定风量 m <sup>3</sup> /h	Capacitance 电容 μF	Noise level 噪音 dBA	Net weight 净重 kg
LXFFG2E133/50-M92/25-****	220	50	0.40	85	2350	280	3	70	2.5

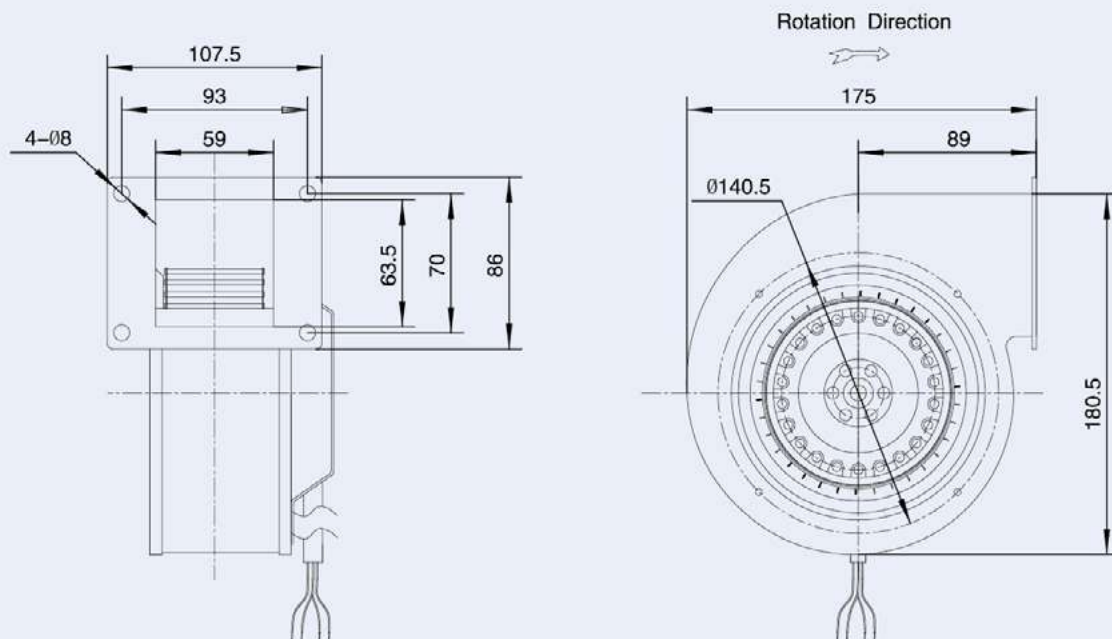

# LXF 单进风离心风机 Single Inlet Centrifugal Fans (AC)

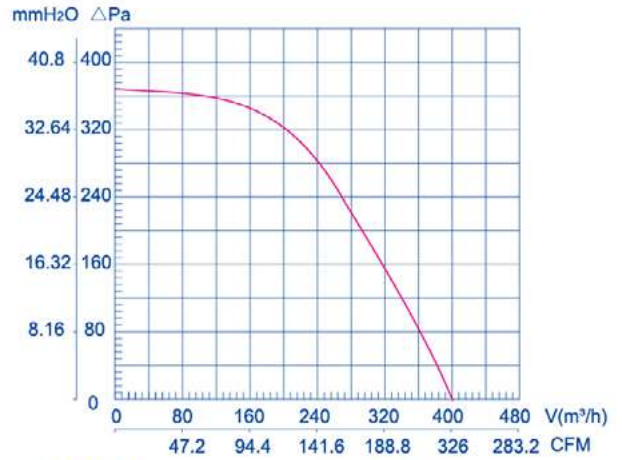

### 使用说明:

工作方式: S1  
 绝缘等级: B级/F级  
 环境温度: -25℃~+60℃  
 防护等级: IP44

### Instructions:

Operation mode: S1  
 Insulation class: B/F  
 Ambient temperature: -25℃~+60℃  
 Type of protection: IP44

Type 型号	Rated voltage 额定电压 V	Frequency 频率 Hz	Current 额定电流 A	Input power 输入功率 W	Rated speed 额定转速 r/min	Air Volume 额定风量 m <sup>3</sup> /h	Capacitance 电容 μF	Noise level 噪音 dBA	Net weight 净重 Kg
LXFFG2E133/73-M92/35-****	220	50	0.59	127	2520	400	3	72	4

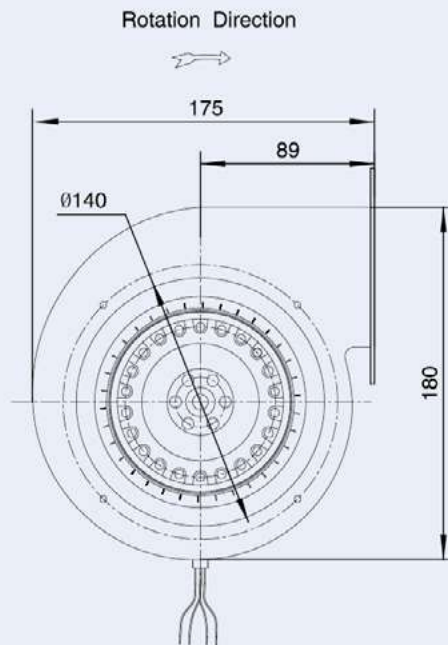
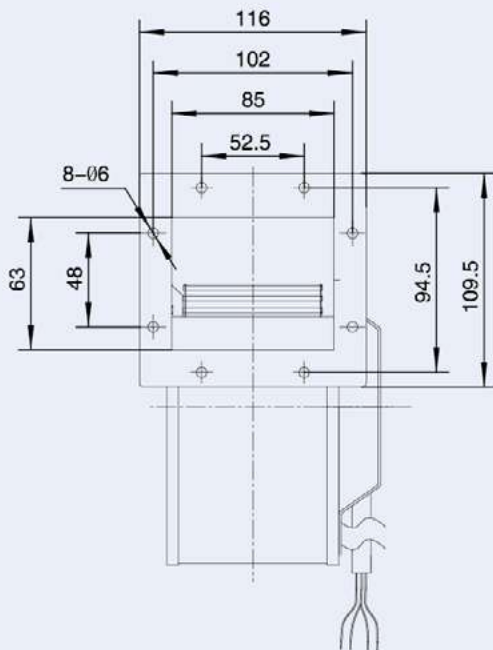



**LXF** 单进风离心风机 **Single Inlet Centrifugal Fans (AC)**

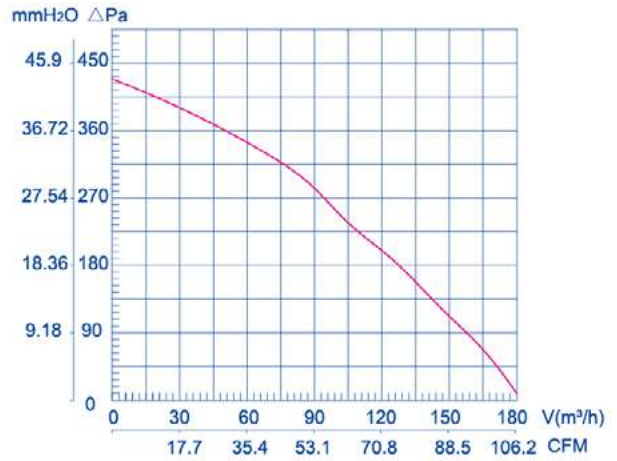

**使用说明:**

工作方式: S1  
绝缘等级: B级/F级  
环境温度: -25℃~+60℃  
防护等级: IP44

**Instructions:**

Operation mode: S1  
Insulation class: B/F  
Ambient temperature: -25℃~+60℃  
Type of protection: IP44

Type 型号	Rated voltage 额定电压 V	Frequency 频率 Hz	Current 额定电流 A	Input power 输入功率 W	Rated speed 额定转速 r/min	Capacitance 电容 μF
LXFFG2E133/44-M72/20-****	220	50	0.22	50	2300	2

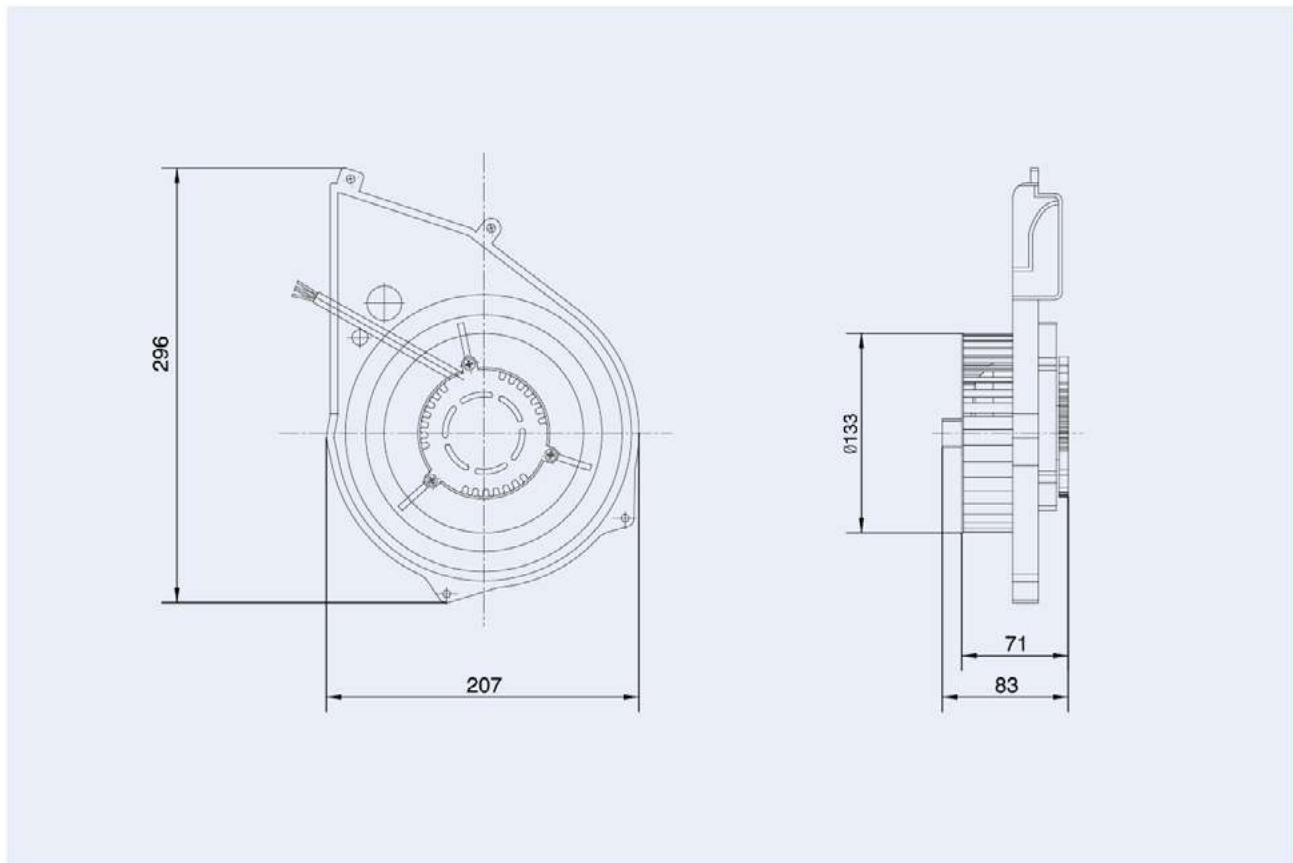

# LXF 单进风离心风机 Single Inlet Centrifugal Fans (AC)

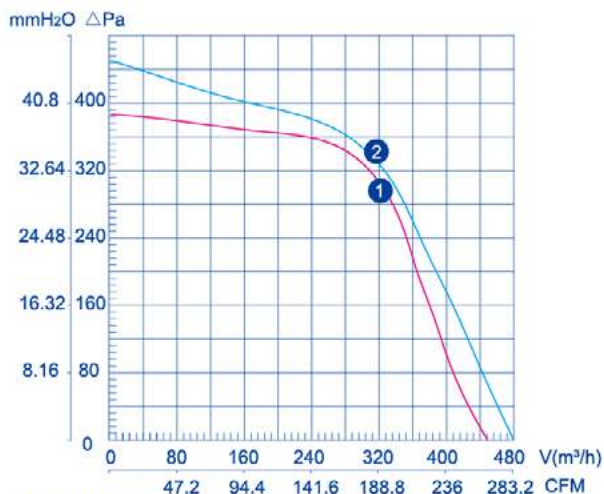

### 使用说明:

工作方式: S1  
 绝缘等级: B级/F级  
 环境温度: -25℃~+60℃  
 防护等级: IP44

### Instructions:

Operation mode: S1  
 Insulation class: B/F  
 Ambient temperature: -25℃~+60℃  
 Type of protection: IP44

Type 型号	Rated voltage 额定电压 V	Frequency 频率 Hz	Current 额定电流 A	Input power 输入功率 W	Rated speed 额定转速 r/min	Air Volume 额定风量 m <sup>3</sup> /h	Capacitance 电容 μF	Noise level 噪音 dBA	Net weight 净重 kg	Curve 曲线
LXFFG2E140/60-M92/35-****	220	50	0.72	155	2380	460	3	72	3.0	①
LXFFG2E140/60-M92/35-****	110	60	1.80	200	2550	480	16	74	3.0	②

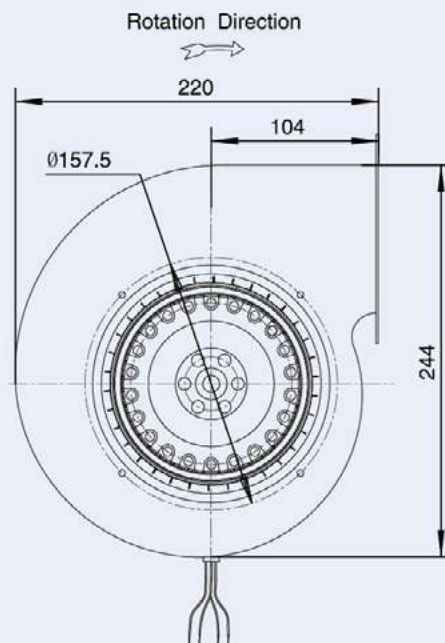
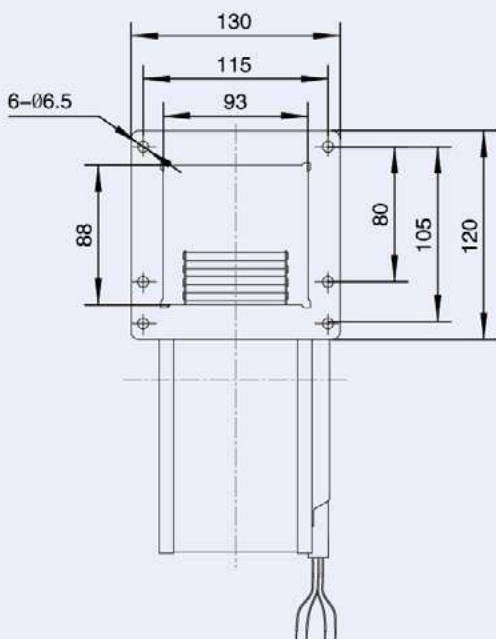

**LXF** 单进风离心风机 **Single Inlet Centrifugal Fans (AC)**

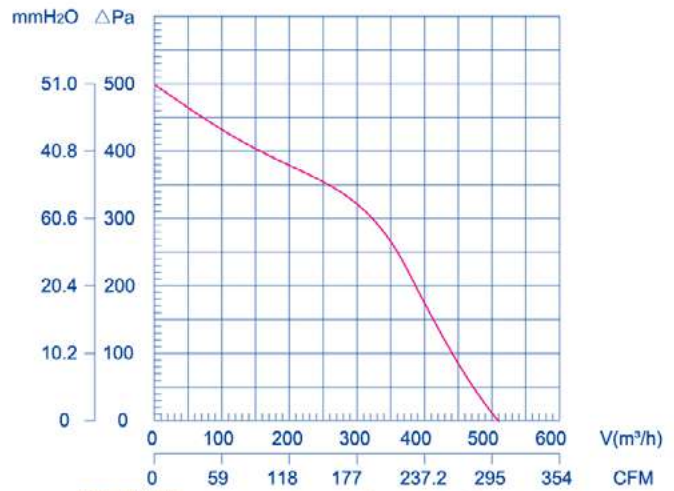

**使用说明:**

工作方式: S1  
绝缘等级: B级/F级  
环境温度: -25℃~+60℃  
防护等级: IP44

**Instructions:**

Operation mode: S1  
Insulation class: B/F  
Ambient temperature: -25℃~+60℃  
Type of protection: IP44

Type 型号	Rated voltage 额定电压 V	Frequency 频率 Hz	Current 额定电流 A	Input power 输入功率 W	Rated speed 额定转速 r/min	Air Volume 额定风量 m³/h	Capacitance 电容 μF	Noise level 噪音 dBA	Net weight 净重 kg
LXFFG2E150/70-M92/35-****	220	50	0.72	157	2200	510	3	74	4.0

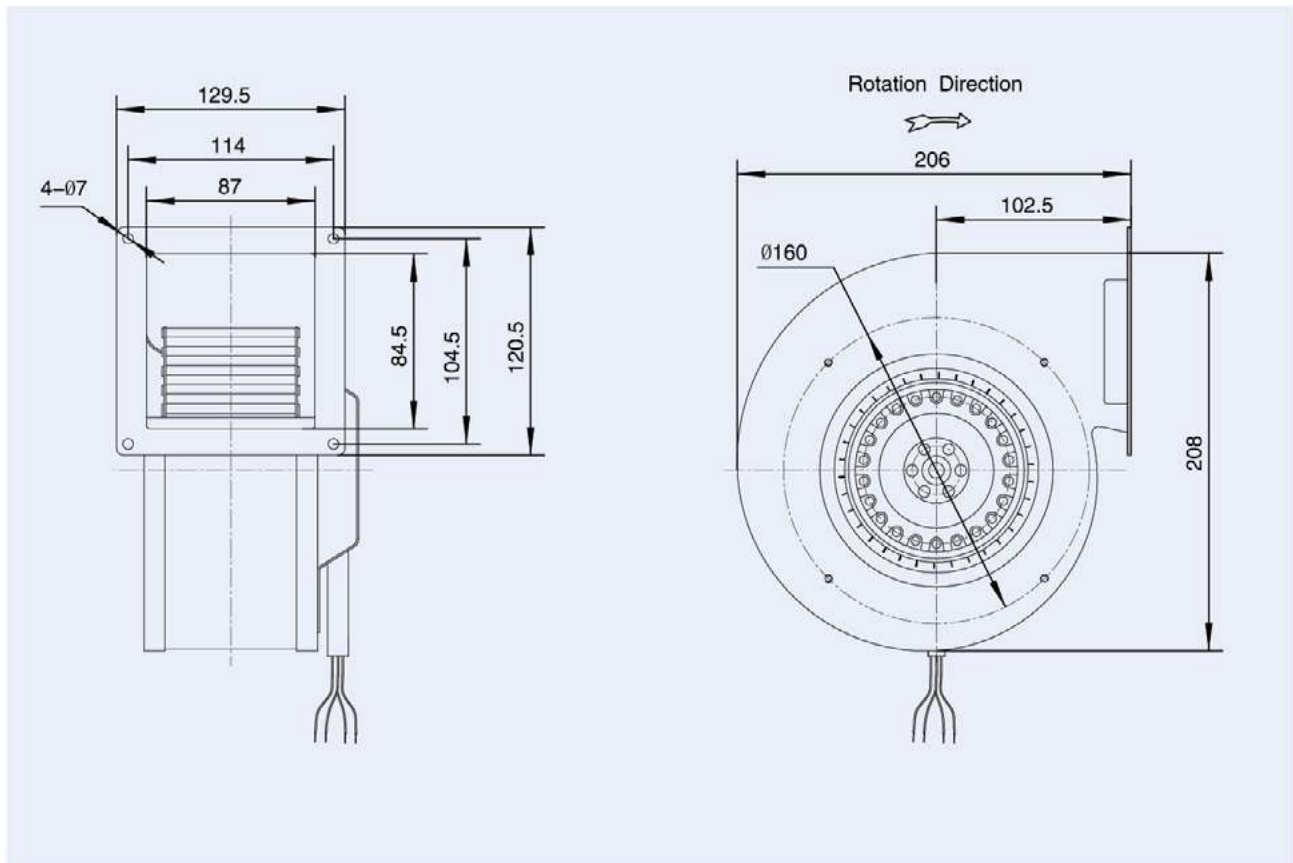

# LXF 单进风离心风机 Single Inlet Centrifugal Fans (AC)

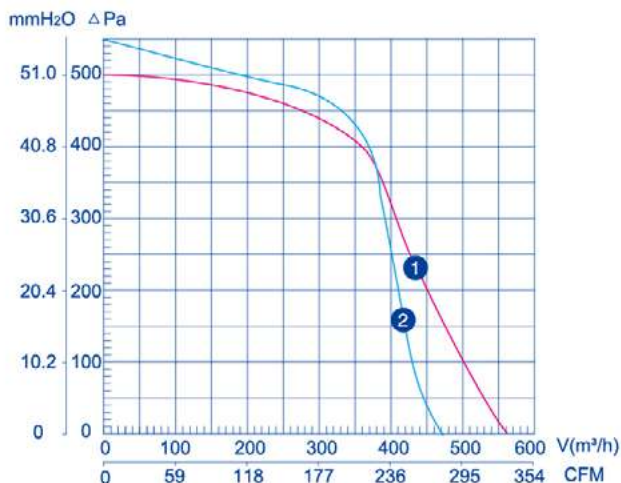

### 使用说明:

工作方式: S1  
 绝缘等级: B级/F级  
 环境温度: -25℃~+60℃  
 防护等级: IP44

### Instructions:

Operation mode: S1  
 Insulation class: B/F  
 Ambient temperature: -25℃~+60℃  
 Type of protection: IP44

Type 型号	Rated voltage 额定电压 V	Frequency 频率 Hz	Current 额定电流 A	Input power 输入功率 W	Rated speed 额定转速 r/min	Air Volume 额定风量 m <sup>3</sup> /h	Capacitance 电容 μF	Noise level 噪音 dBA	Net weight 净重 kg	Curve 曲线
LXFFG2E160/60-M92/35-****	220	50	0.92	195	1840	560	3	76	4.0	①
LXFFG2E160/60-M92/35-****	110	60	2.10	230	1700	470	16	74	4.0	②

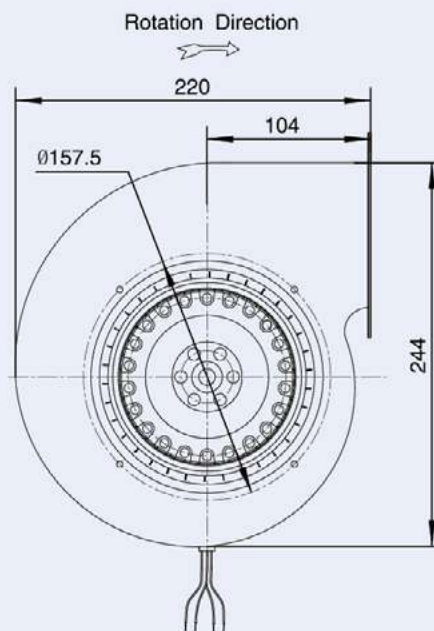
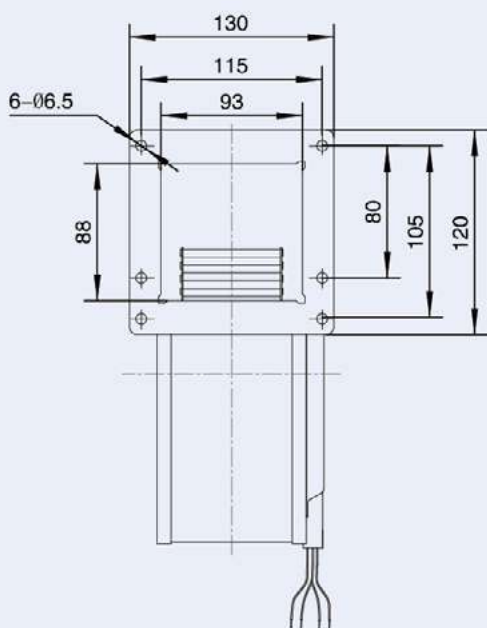

**LXF** 单进风离心风机 **Single Inlet Centrifugal Fans (AC)**

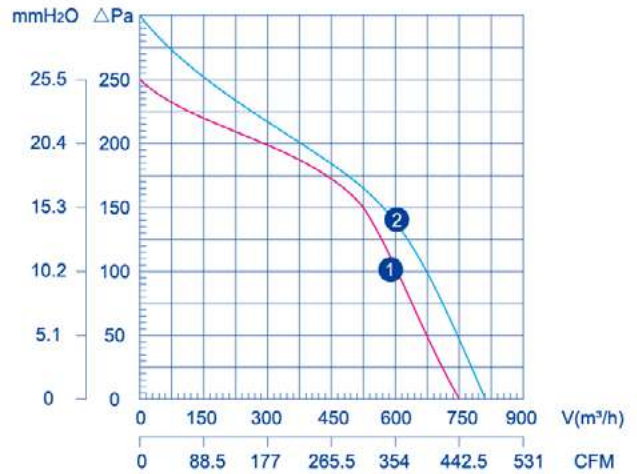

**使用说明:**

工作方式: S1  
绝缘等级: B级/F级  
环境温度: -25℃~+60℃  
防护等级: IP44

**Instructions:**

Operation mode: S1  
Insulation class: B/F  
Ambient temperature: -25℃~+60℃  
Type of protection: IP44

Type 型号	Rated voltage 额定电压 V	Frequency 频率 Hz	Current 额定电流 A	Input power 输入功率 W	Rated speed 额定转速 r/min	Air Volume 额定风量 m <sup>3</sup> /h	Capacitance 电容 μF	Noise level 噪音 dBA	Net weight 净重 kg	Curve 曲线
LXFFG4E180/90-M102/34-****	220	50	0.66	140	1340	750	4	66	5.0	①
	220	60	1.00	210	1580	820	4	68	5.0	②

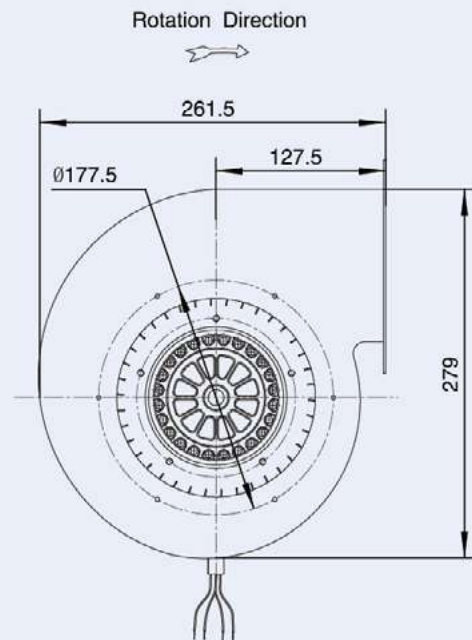
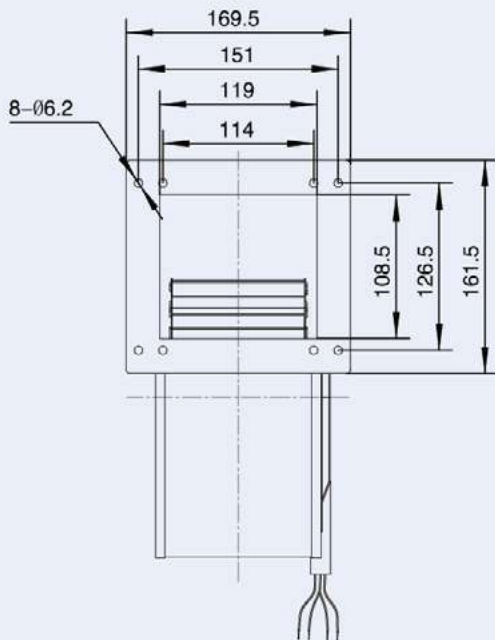

# LXF 固体燃料加热系统用风机 Fans For solid fuel heating systems (AC)

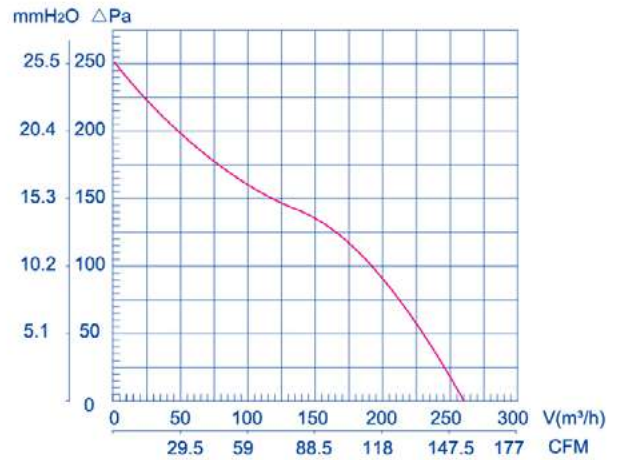

### 使用说明:

工作方式: S1  
 绝缘等级: B级/F级  
 环境温度: -25℃~+100℃  
 防护等级: IP44

### Instructions:

Operation mode: S1  
 Insulation class: B/F  
 Ambient temperature: -25℃~+100℃  
 Type of protection: IP44

Type 型号	Rated voltage 额定电压 V	Frequency 频率 Hz	Current 额定电流 A	Input power 输入功率 W	Rated speed 额定转速 r/min	Air Volume 额定风量 m <sup>3</sup> /h	Capacitance 电容 μF	Noise level 噪音 dBA	Net weight 净重 kg
LXFB2E150/20-M92/15-****	220	50	0.14	31	2300	260	1.0	56	1.5

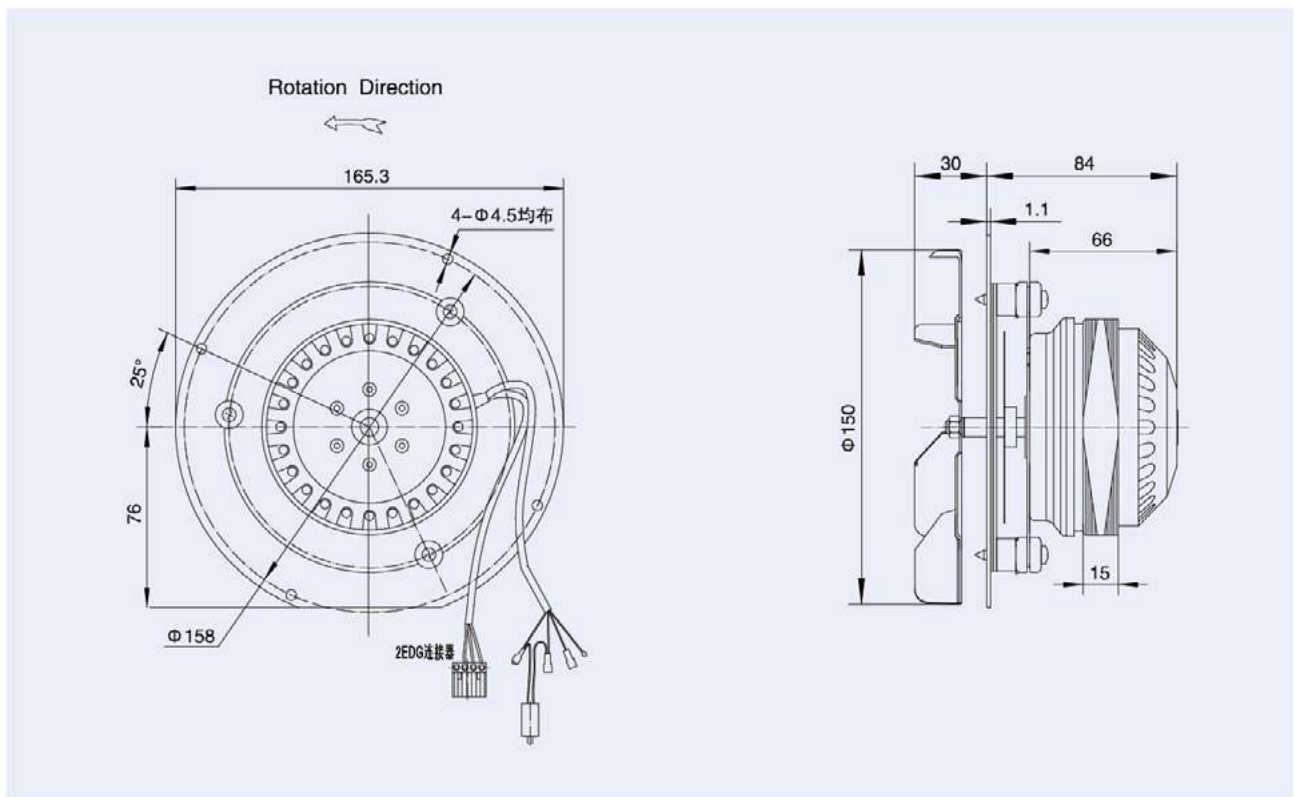

**LXF** 固体燃料加热系统用风机 **Fans For solid fuel heating systems (AC)**

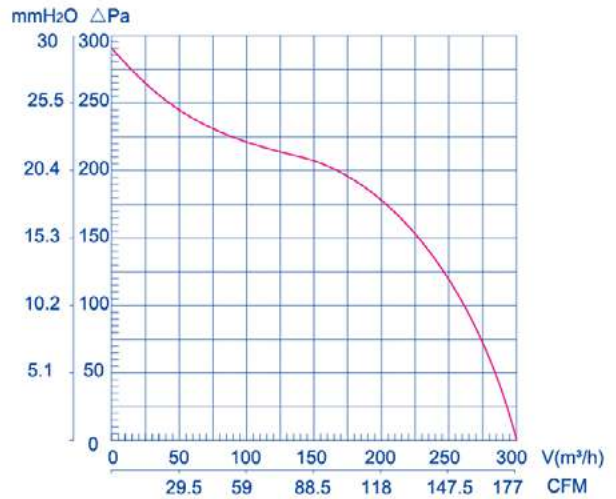

**使用说明:**

工作方式: S1  
 绝缘等级: B级/F级  
 环境温度: -25℃~+100℃  
 防护等级: IP44

**Instructions:**

Operation mode: S1  
 Insulation class: B/F  
 Ambient temperature: -25℃~+100℃  
 Type of protection: IP44

Type 型号	Rated voltage 额定电压 V	Frequency 频率 Hz	Current 额定电流 A	Input power 输入功率 W	Rated speed 额定转速 r/min	Air Volume 额定风量 m <sup>3</sup> /h	Capacitance 电容 μF	Noise level 噪音 dBA	Net weight 净重 kg
LXFB2E180/45-M92/25-****	220	50	0.45	100	1950	310	2.0	61	2.5

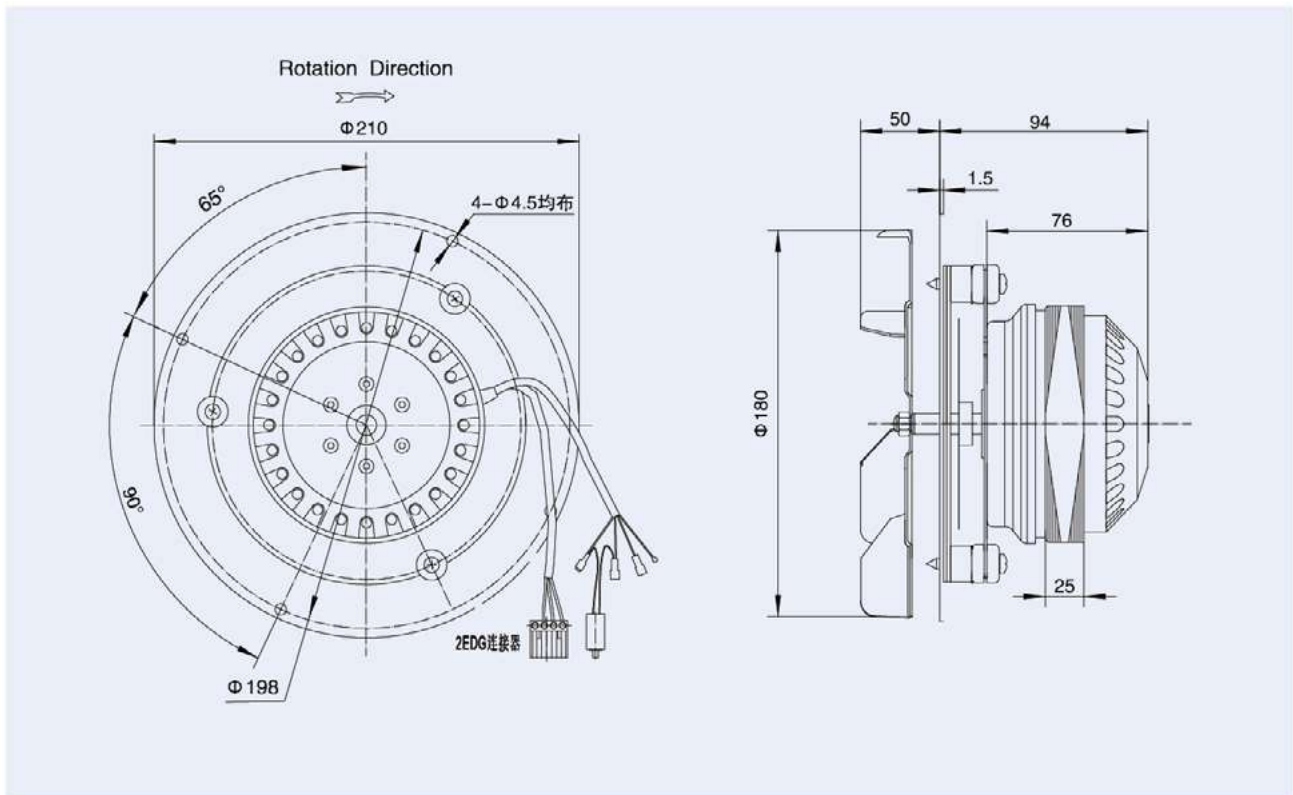

# LXF 交流后倾式离心风机 Backward Centrifugal Fans(AC)

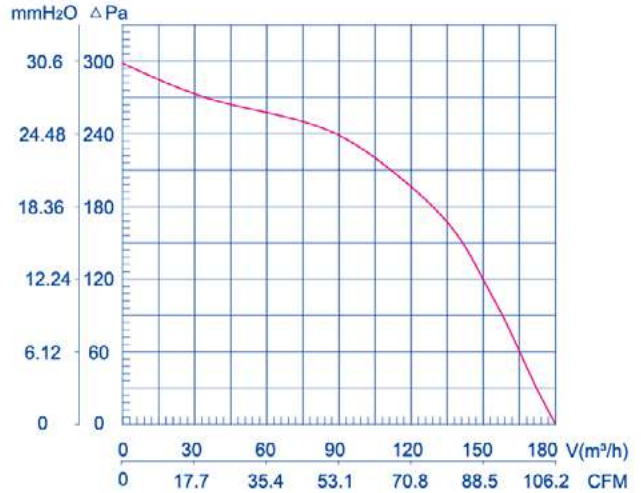

### 使用说明:

工作方式: S1  
 绝缘等级: B级/F级  
 环境温度: -25℃--+60℃  
 防护等级: IP44

### Instructions:

Operation mode: S1  
 Insulation class: B/F  
 Ambient temperature: -25℃--+60℃  
 Type of protection: IP44

Type 型号	Rated voltage 额定电压 V	Frequency 频率 Hz	Current 额定电流 A	Input power 输入功率 W	Rated speed 额定转速 r/min	Air Volume 额定风量 m³/h	Capacitance 电容 μ F	Noise level 噪音 dBA	Net weight 净重 kg
LXFB2E133/42-P72/15-****	220	50	0.12	26	2620	205	1.0	50	0.9

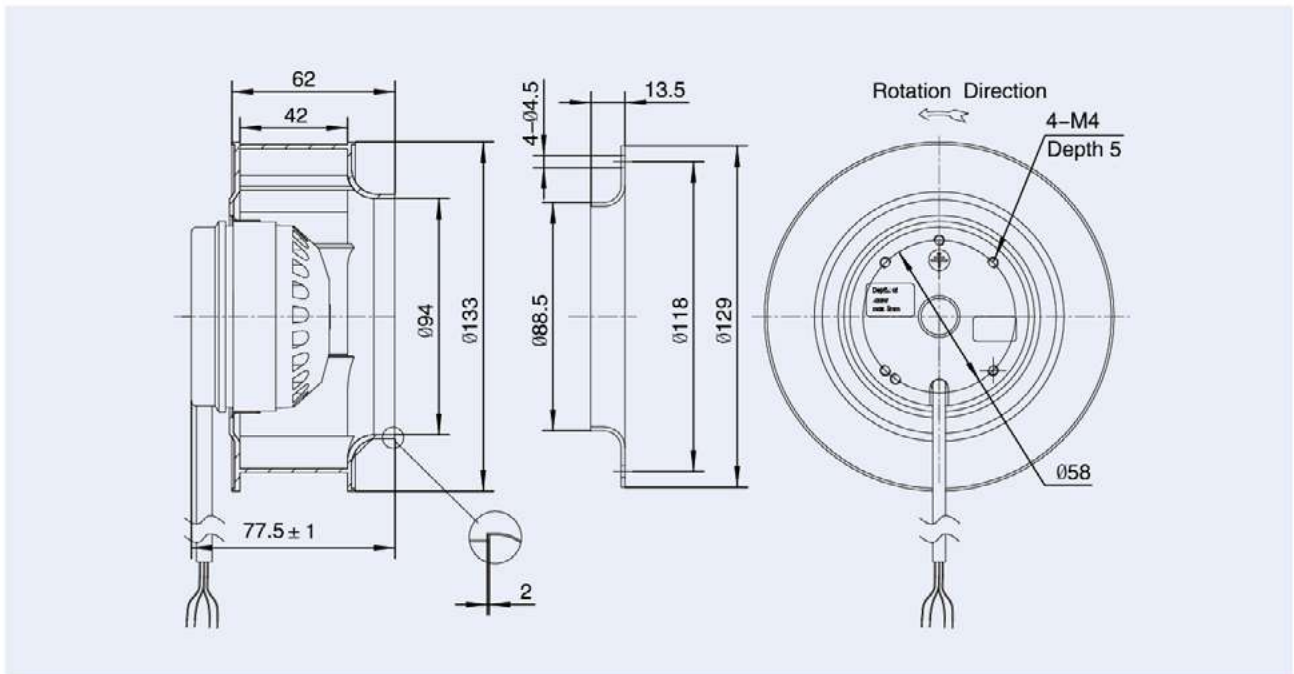



**LXF** 交流后倾式离心风机 **Backward Centrifugal Fans(AC)**

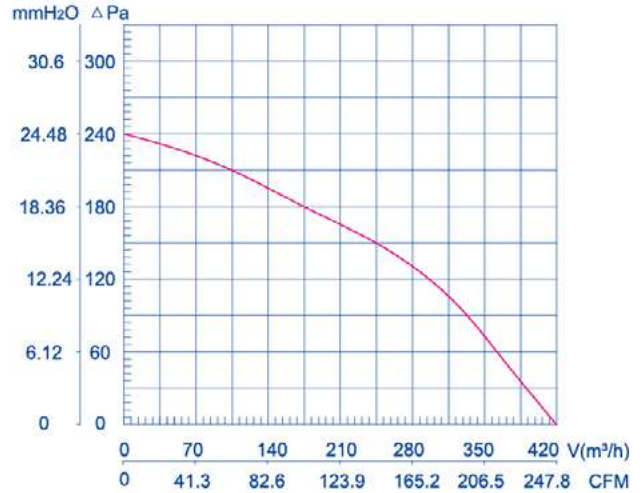

**使用说明:**

工作方式: S1  
绝缘等级: B级/F级  
环境温度: -25℃--+60℃  
防护等级: IP44

**Instructions:**

Operation mode: S1  
Insulation class: B/F  
Ambient temperature: -25℃--+60℃  
Type of protection: IP44

Type 型号	Rated voltage 额定电压 V	Frequency 频率 Hz	Current 额定电流 A	Input power 输入功率 W	Rated speed 额定转速 r/min	Air Volume 额定风量 m³/h	Capacitance 电容 μF	Noise level 噪音 dBA	Net weight 净重 kg
LXFB2E175/42-P92/15-****	220	50	0.21	46	2550	430	2	63	1.1

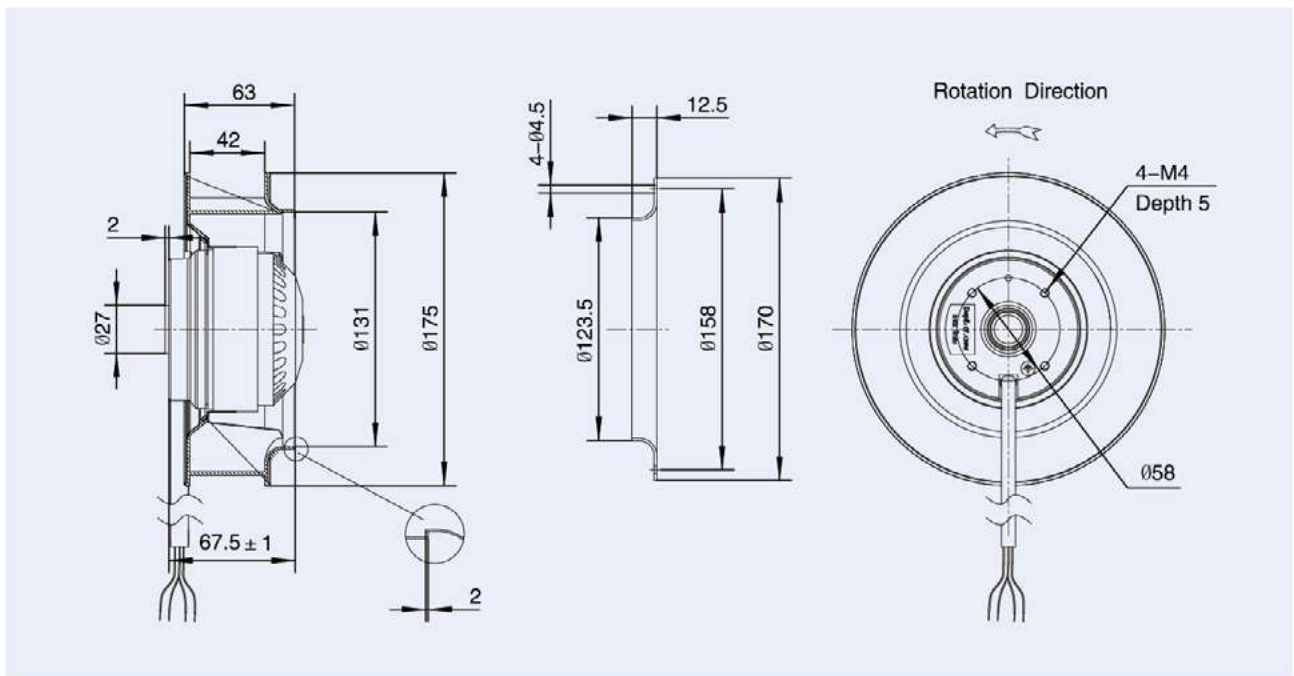

# LXF 交流后倾式离心风机 Backward Centrifugal Fans(AC)

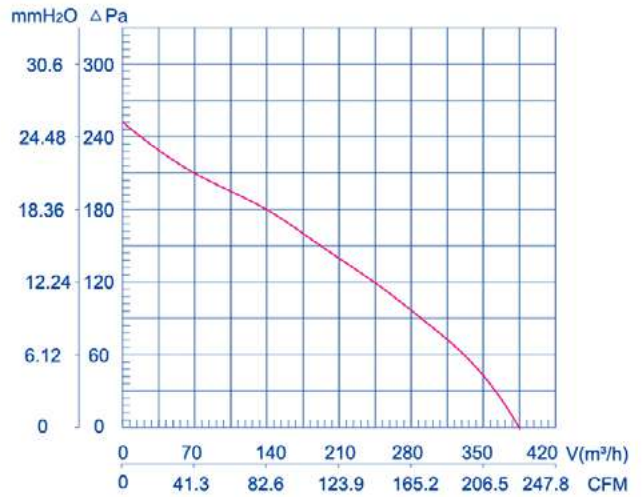

### 使用说明:

工作方式: S1  
 绝缘等级: B级/F级  
 环境温度: -25℃~+60℃  
 防护等级: IP44

### Instructions:

Operation mode: S1  
 Insulation class: B/F  
 Ambient temperature: -25℃~+60℃  
 Type of protection: IP44

Type 型号	Rated voltage 额定电压 V	Frequency 频率 Hz	Current 额定电流 A	Input power 输入功率 W	Rated speed 额定转速 r/min	Air Volume 额定风量 m³/h	Capacitance 电容 μF	Noise level 噪音 dBA	Net weight 净重 kg
LXFB2E180/30-P92/15-****	220	50	0.25	50	2500	380	2	63	1.2

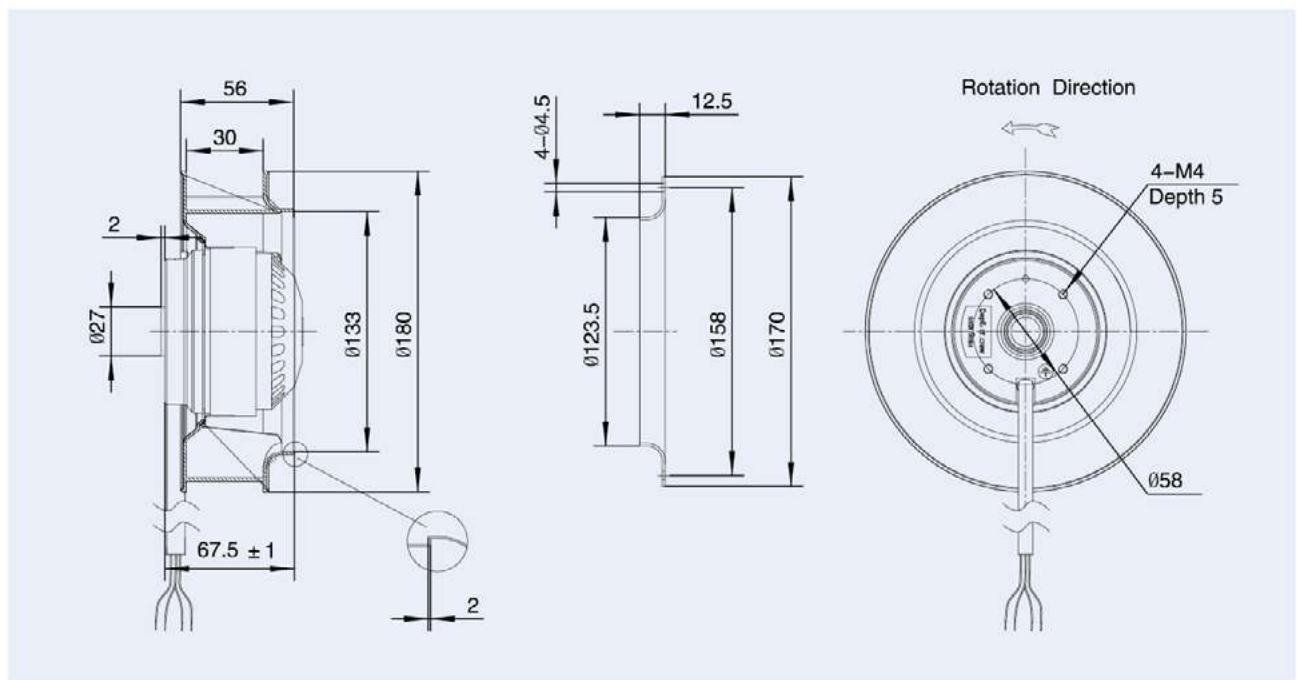

**LXF** 交流后倾式离心风机 **Backward Centrifugal Fans(AC)**

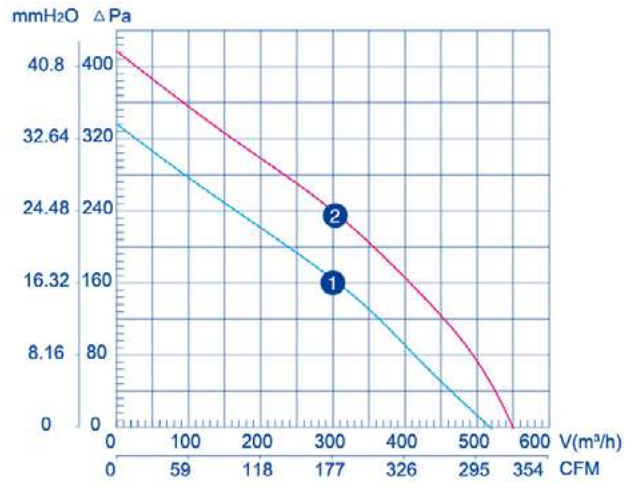

**使用说明:**

工作方式: S1  
绝缘等级: B级/F级  
环境温度: -25℃--+60℃  
防护等级: IP44

**Instructions:**

Operation mode: S1  
Insulation class: B/F  
Ambient temperature: -25℃--+60℃  
Type of protection: IP44

Type 型号	Rated voltage 额定电压 V	Frequency 频率 Hz	Current 额定电流 A	Input power 输入功率 W	Rated speed 额定转速 r/min	Air Volume 额定风量 m³/h	Noise level 噪音 dBA	Net weight 净重 kg	Capacitance 电容 μF	Curve 曲线
LXFB2E190/44-P92/15-****	220	50	0.25	56.5	2340	520	67	1.2	2	①
LXFB2E190/44-P92/15-****	220	60	0.30	71	2620	550	70	1.2	2	②

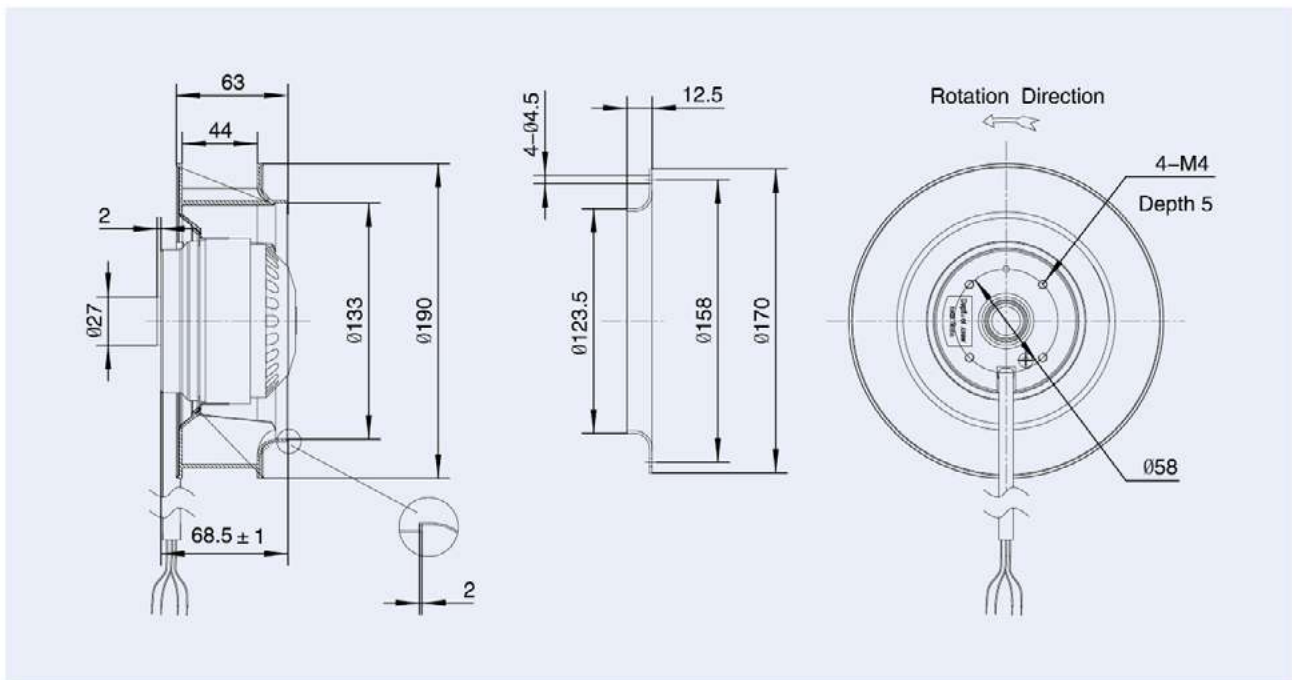

# LXF 交流后倾式离心风机 Backward Centrifugal Fans(AC)

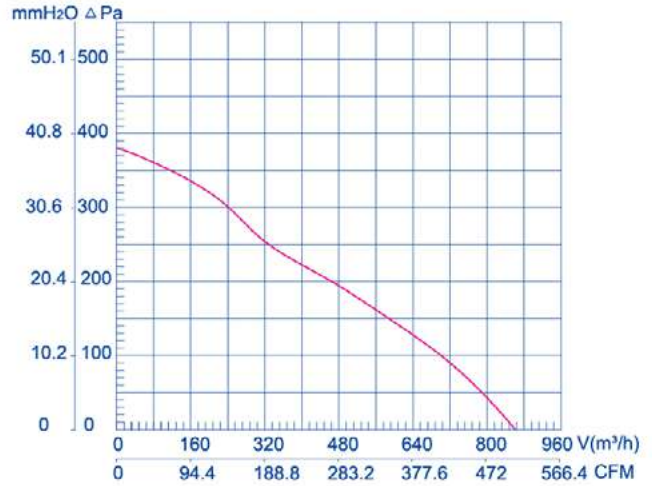

### 使用说明:

工作方式: S1  
 绝缘等级: B级/F级  
 环境温度: -25℃~+60℃  
 防护等级: IP44

### Instructions:

Operation mode: S1  
 Insulation class: B/F  
 Ambient temperature: -25℃~+60℃  
 Type of protection: IP44

Type 型号	Rated voltage 额定电压 V	Frequency 频率 Hz	Current 额定电流 A	Input power 输入功率 W	Rated speed 额定转速 r/min	Air Volume 额定风量 m³/h	Capacitance 电容 μF	Noise level 噪音 dBA	Net weight 净重 kg
LXFB2E220/44-P92/25-****	220	50	0.37	81	2500	850	3	70	1.8

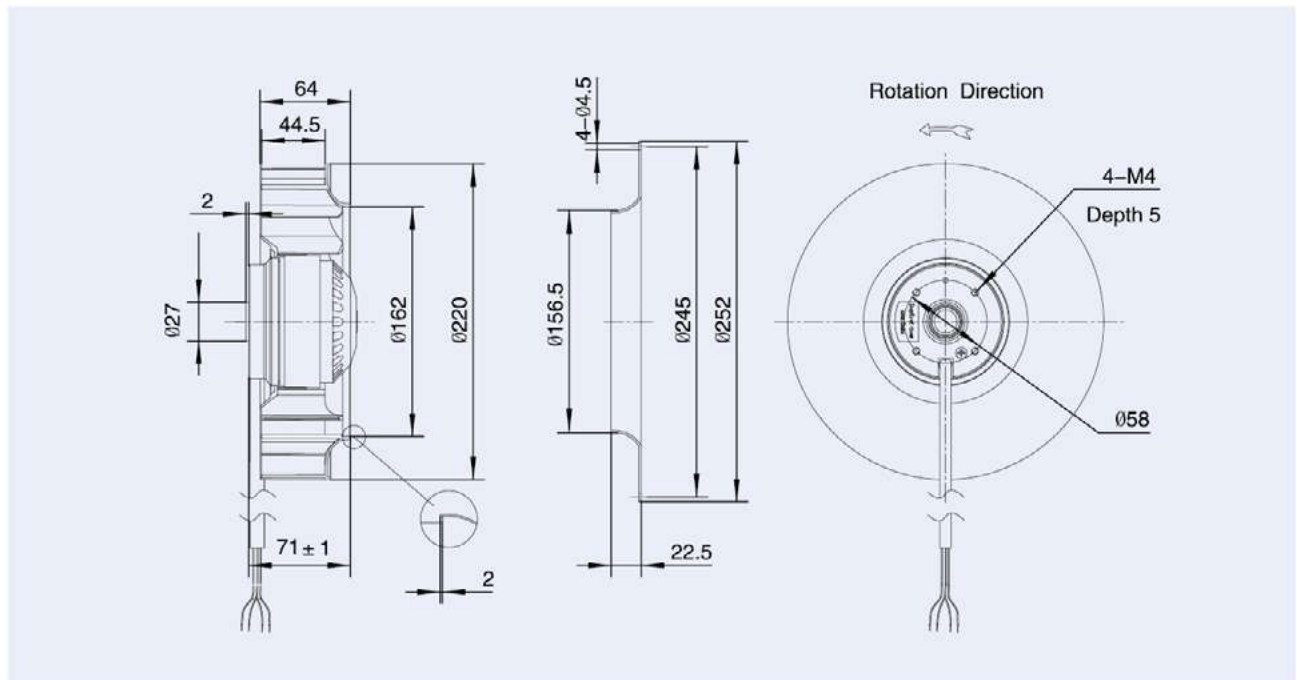

**LXF** 交流后倾式离心风机 **Backward Centrifugal Fans(AC)**

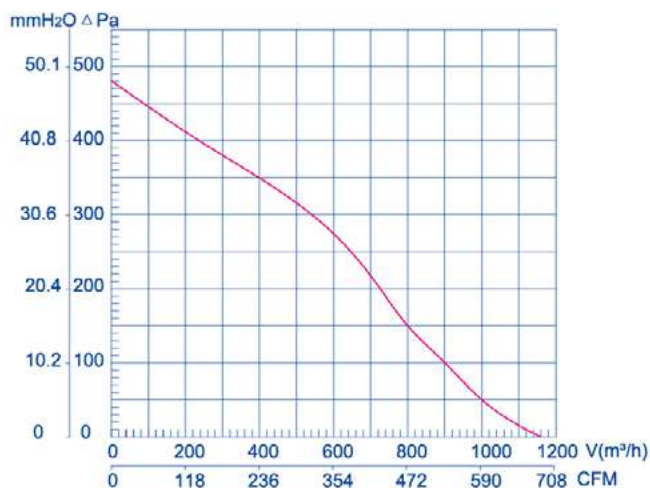

**使用说明:**

工作方式: S1  
绝缘等级: B级/F级  
环境温度: -25℃~+60℃  
防护等级: IP44

**Instructions:**

Operation mode: S1  
Insulation class: B/F  
Ambient temperature: -25℃~+60℃  
Type of protection: IP44

Type 型号	Rated voltage 额定电压 V	Frequency 频率 Hz	Current 额定电流 A	Input power 输入功率 W	Rated speed 额定转速 r/min	Air Volume 额定风量 m³/h	Capacitance 电容 μF	Noise level 噪音 dBA	Net weight 净重 kg
LXFB2E225/62-P92/35-****	220	50	0.63	138	2640	1160	4	72	2.4

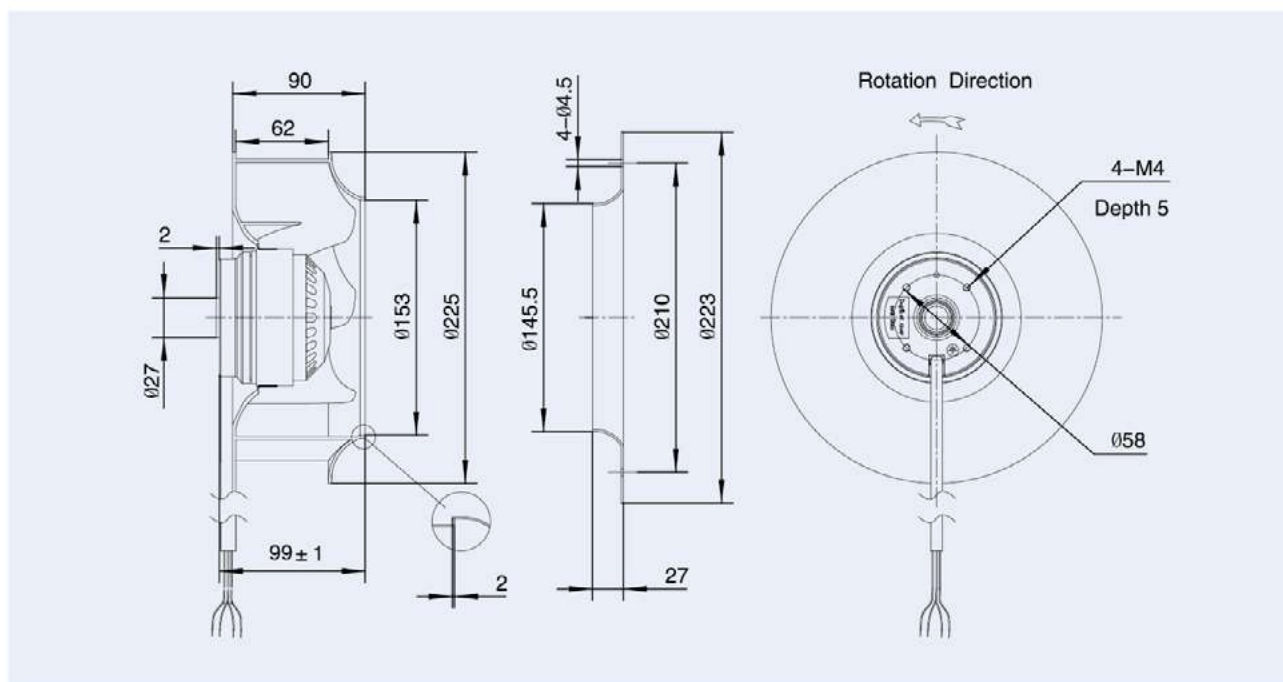

# LXF 交流后倾式离心风机 Backward Centrifugal Fans(AC)

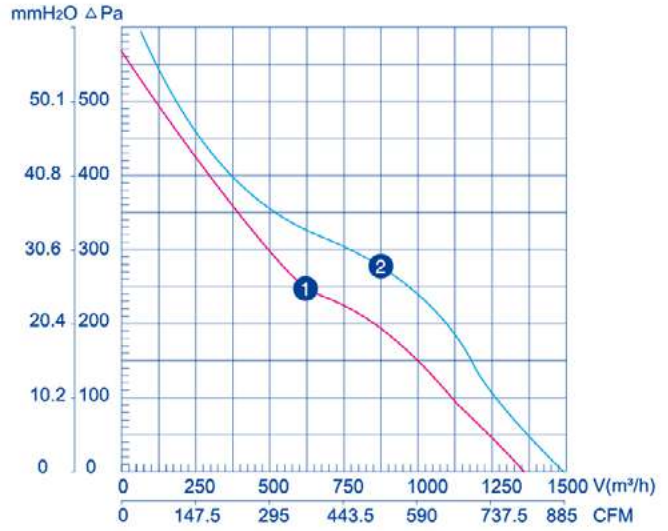

### 使用说明:

工作方式: S1  
 绝缘等级: B级/F级  
 环境温度: -25℃~+60℃  
 防护等级: IP44

### Instructions:

Operation mode: S1  
 Insulation class: B/F  
 Ambient temperature: -25℃~+60℃  
 Type of protection: IP44

Type 型号	Rated voltage 额定电压 V	Frequency 频率 Hz	Current 额定电流 A	Input power 输入功率 W	Rated speed 额定转速 r/min	Air Volume 额定风量 m³/h	Capacitance 电容 μF	Noise level 噪音 dBA	Net weight 净重 kg	Curve 曲线
LXFB2E250/48-M92/35-****	220	50	0.62	135	2500	1250	3	74	3	①
LXFB2E250/56-M92/35-****	220	50	0.78	160	2450	1400	4	72	3.3	②

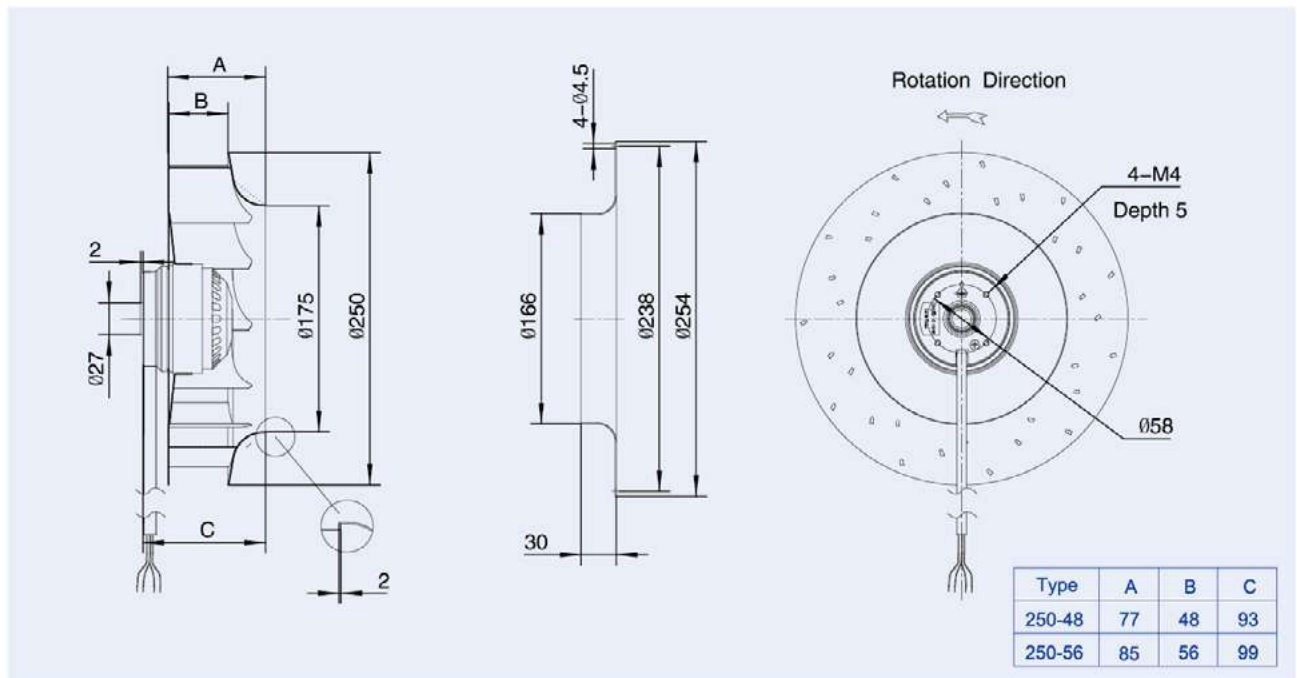

**LXF** 交流后倾式离心风机 **Backward Centrifugal Fans(AC)**

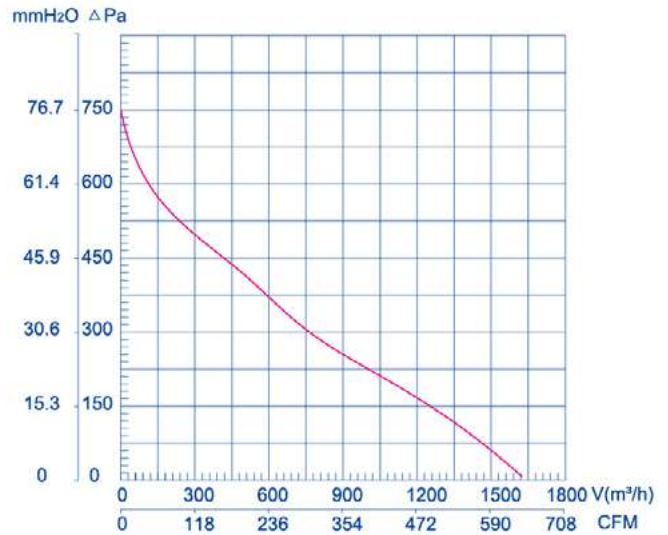

**使用说明:**

工作方式: S1  
绝缘等级: B级/F级  
环境温度: -25℃~+60℃  
防护等级: IP44

**Instructions:**

Operation mode: S1  
Insulation class: B/F  
Ambient temperature: -25℃~+60℃  
Type of protection: IP44

Type 型号	Rated voltage 额定电压 V	Frequency 频率 Hz	Current 额定电流 A	Input power 输入功率 W	Rated speed 额定转速 r/min	Air Volume 额定风量 m³/h	Capacitance 电容 μF	Noise level 噪音 dBA	Net weight 净重 kg
LXFB2E280/50-M92/45-****	220	50	0.93	205	2330	1610	6	75	3.5

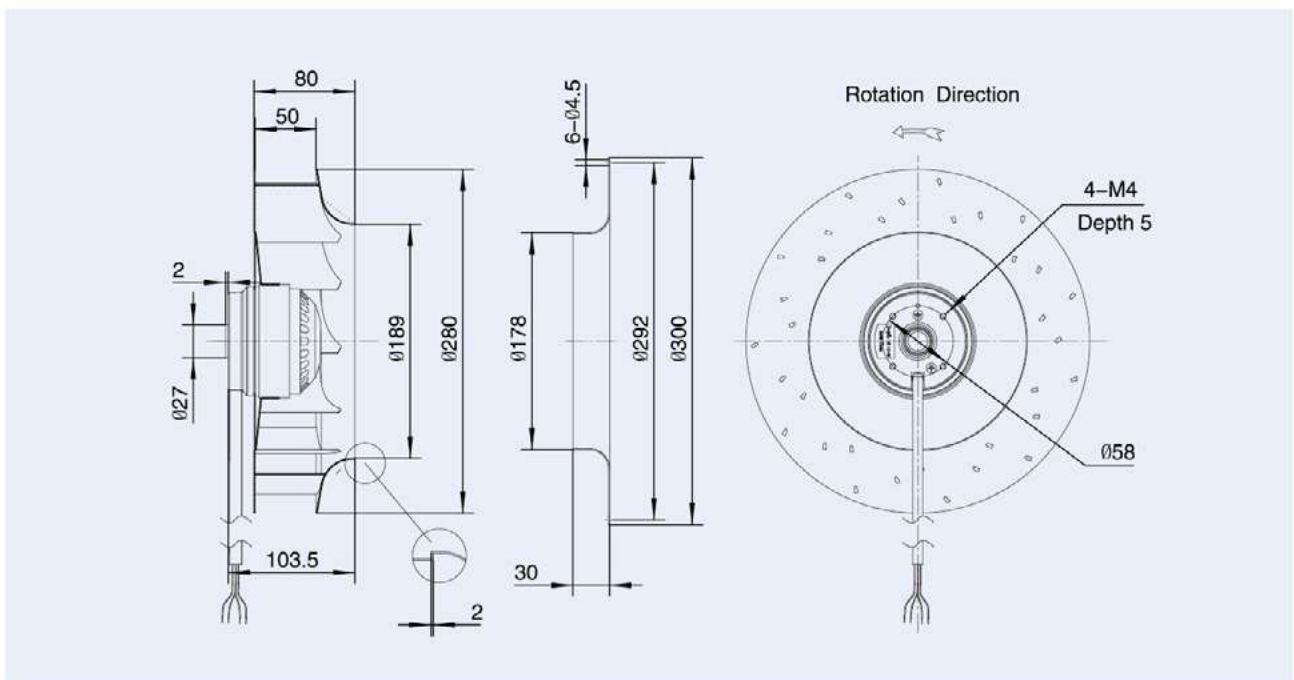

# LXF 交流后倾式离心风机 Backward Centrifugal Fans(AC)

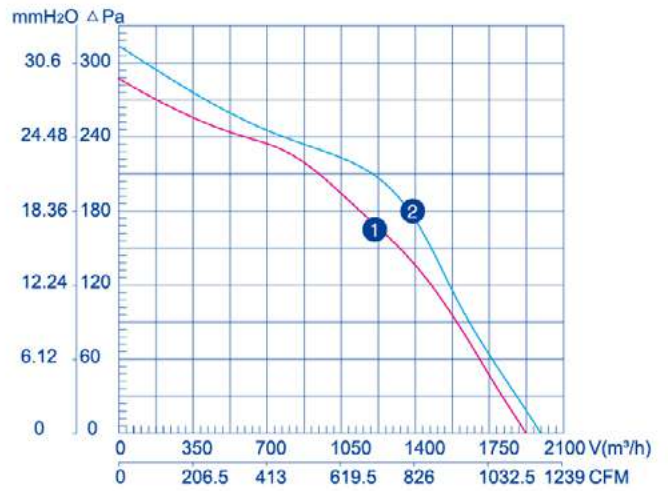

### 使用说明:

工作方式: S1  
 绝缘等级: B级/F级  
 环境温度: -25℃--+60℃  
 防护等级: IP44

### Instructions:

Operation mode: S1  
 Insulation class: B/F  
 Ambient temperature: -25℃--+60℃  
 Type of protection: IP44

Type 型号	Rated voltage 额定电压 V	Frequency 频率 Hz	Current 额定电流 A	Input power 输入功率 W	Rated speed 额定转速 r/min	Air Volume 额定风量 m³/h	Capacitance 电容 μF	Noise level 噪音 dBA	Net weight 净重 kg	Curve 曲线
LXFB4E315/100-M102/34-****	220	50	0.60	135	1400	1820	4	64	3.7	①
LXFB4E315/100-M102/34-****	220	60	0.80	180	1580	2030	4	66	3.7	②

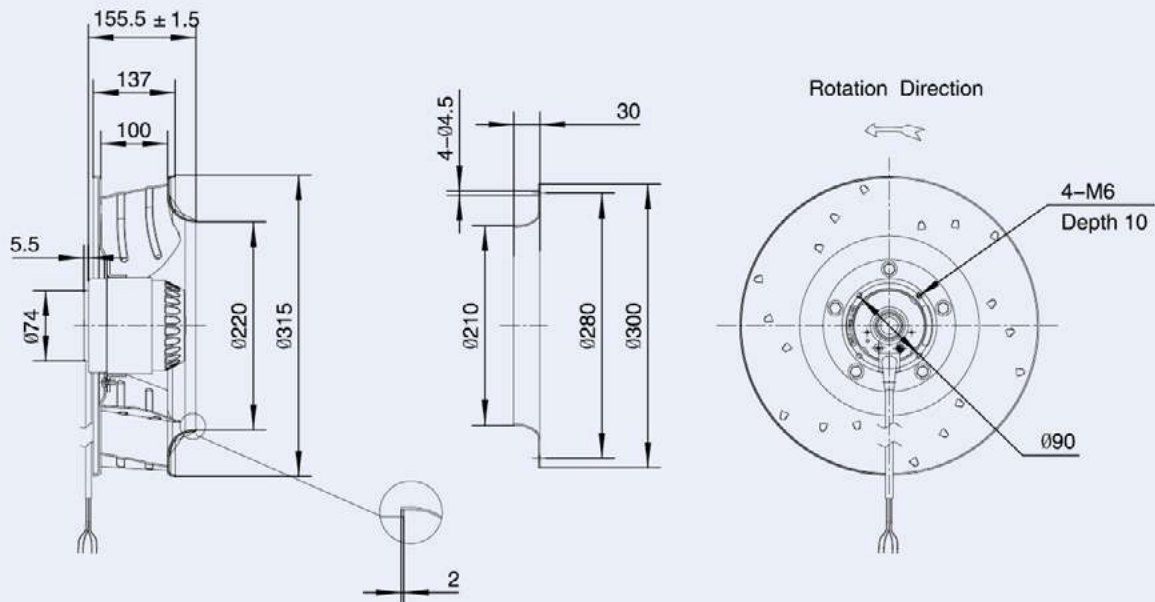



**LXF** 交流后倾式离心风机 **Backward Centrifugal Fans(AC)**

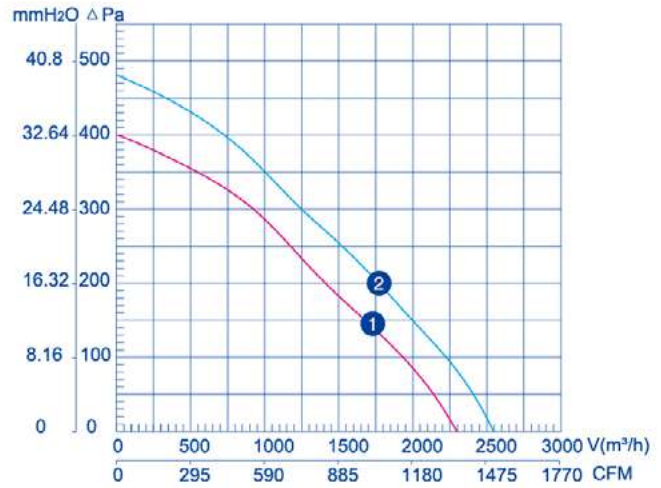

**使用说明:**

工作方式: S1  
绝缘等级: B级/F级  
环境温度: -25℃~+60℃  
防护等级: IP44

**Instructions:**

Operation mode: S1  
Insulation class: B/F  
Ambient temperature: -25℃~+60℃  
Type of protection: IP44

Type 型号	Rated voltage 额定电压 V	Frequency 频率 Hz	Current 额定电流 A	Input power 输入功率 W	Rated speed 额定转速 r/min	Air Volume 额定风量 m³/h	Capacitance 电容 μF	Noise level 噪音 dBA	Net weight 净重 kg	Curve 曲线
LXFB4E355/100-M102/47-****	220	50	0.78	170	1380	2450	6	66	4.6	①
LXFB4E355/100-M102/47-****	220	60	1.20	245	1450	2580	6	68	4.6	②

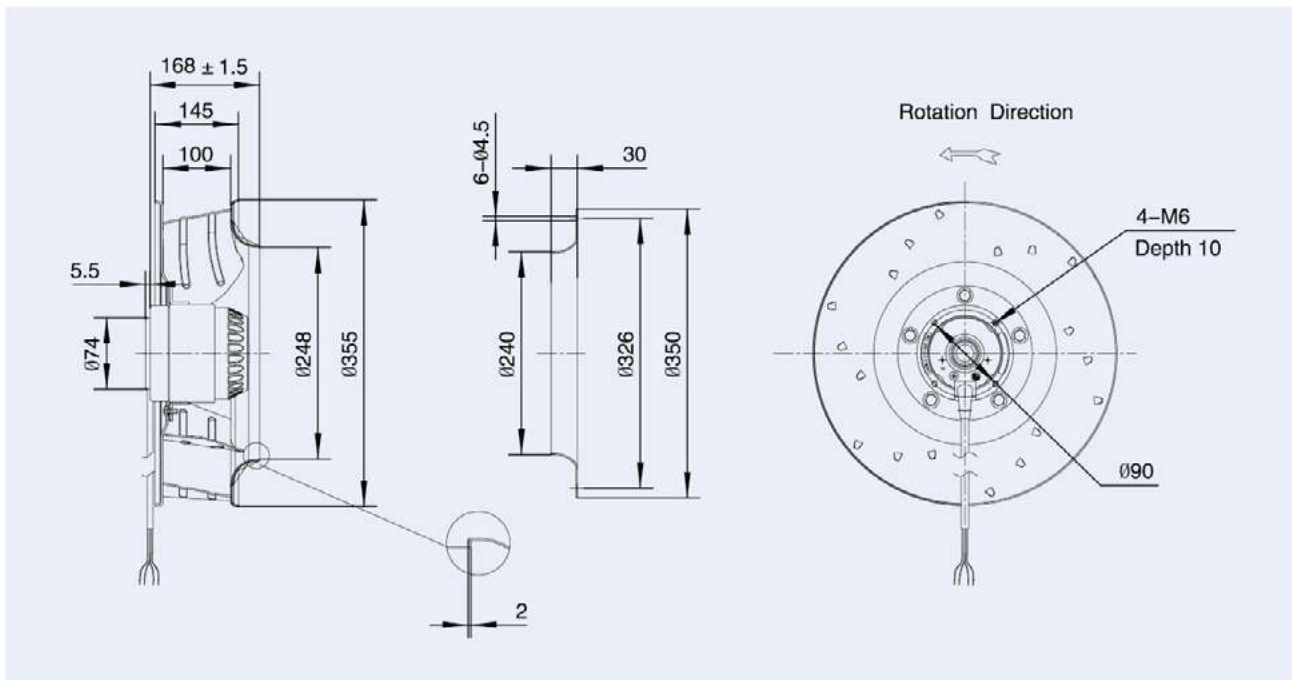

# LXF 交流后倾式离心风机 Backward Centrifugal Fans(AC)

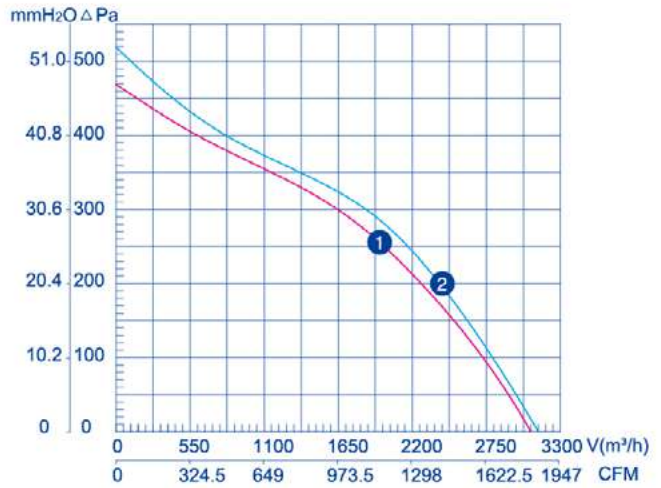

### 使用说明:

工作方式: S1  
 绝缘等级: B级/F级  
 环境温度: -25℃~+60℃  
 防护等级: IP44

### Instructions:

Operation mode: S1  
 Insulation class: B/F  
 Ambient temperature: -25℃~+60℃  
 Type of protection: IP44

Type 型号	Rated voltage 额定电压 V	Frequency 频率 Hz	Current 额定电流 A	Input power 输入功率 W	Rated speed 额定转速 r/min	Air Volume 额定风量 m³/h	Capacitance 电容 μF	Noise level 噪音 dBA	Net weight 净重 kg	Curve 曲线
LXFB4E400/100-M102/60-****	220	50	1.10	240	1380	3100	8	68	5.5	①
LXFB4E400/100-M102/60-****	220	60	1.56	340	1500	3050	8	70	5.5	②

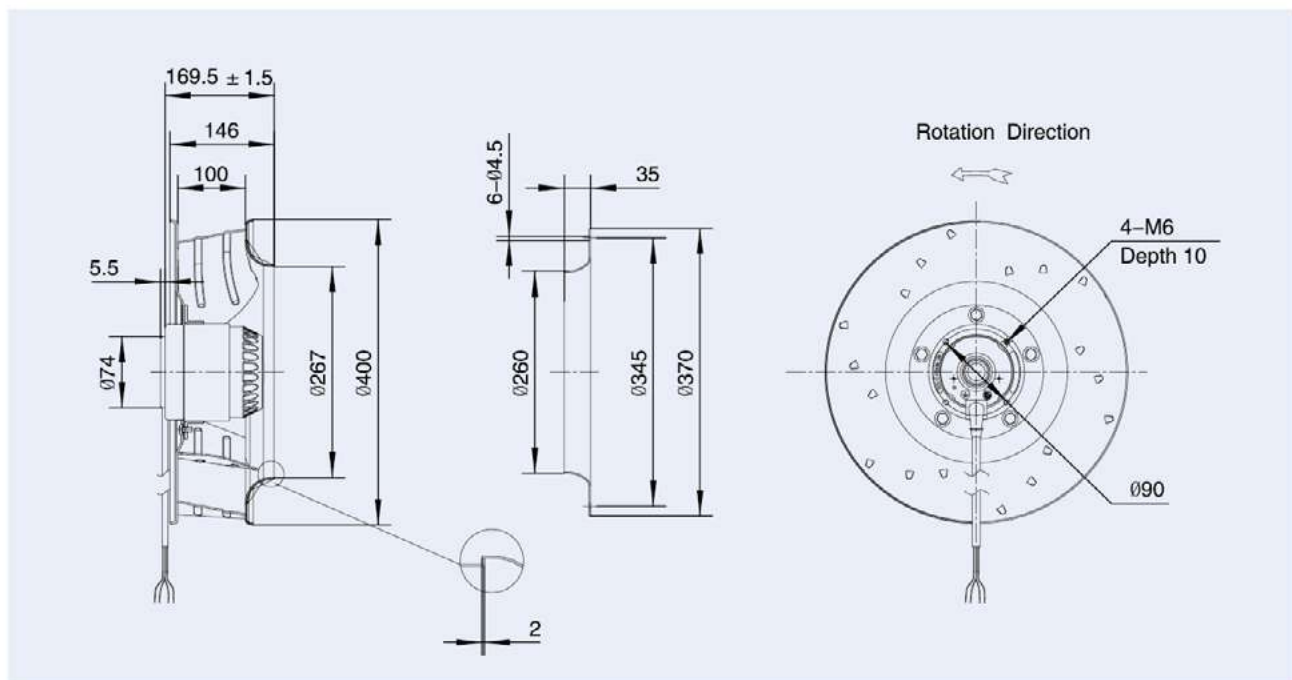

**LXF** 交流后倾式离心风机 **Backward Centrifugal Fans(AC)**

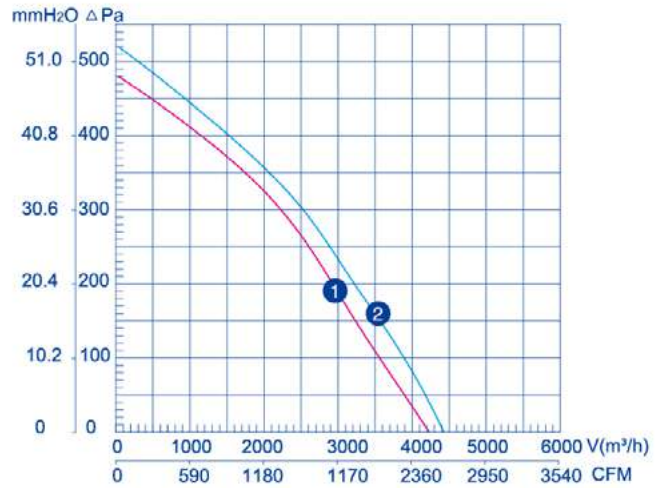

**使用说明:**

工作方式: S1  
绝缘等级: B级/F级  
环境温度: -25℃~+60℃  
防护等级: IP44

**Instructions:**

Operation mode: S1  
Insulation class: B/F  
Ambient temperature: -25℃~+60℃  
Type of protection: IP44

Type 型号	Rated voltage 额定电压 V	Frequency 频率 Hz	Current 额定电流 A	Input power 输入功率 W	Rated speed 额定转速 r/min	Air Volume 额定风量 m³/h	Capacitance 电容 μF	Noise level 噪音 dBA	Net weight 净重 kg	Curve 曲线
LXFB4D400/140-M137/050-****	380	50	0.7	410	1380	4300	\	74	9	②
LXFB4E400/140-M137/050-****	220	50	1.5	430	1350	4100	12	73	9	①

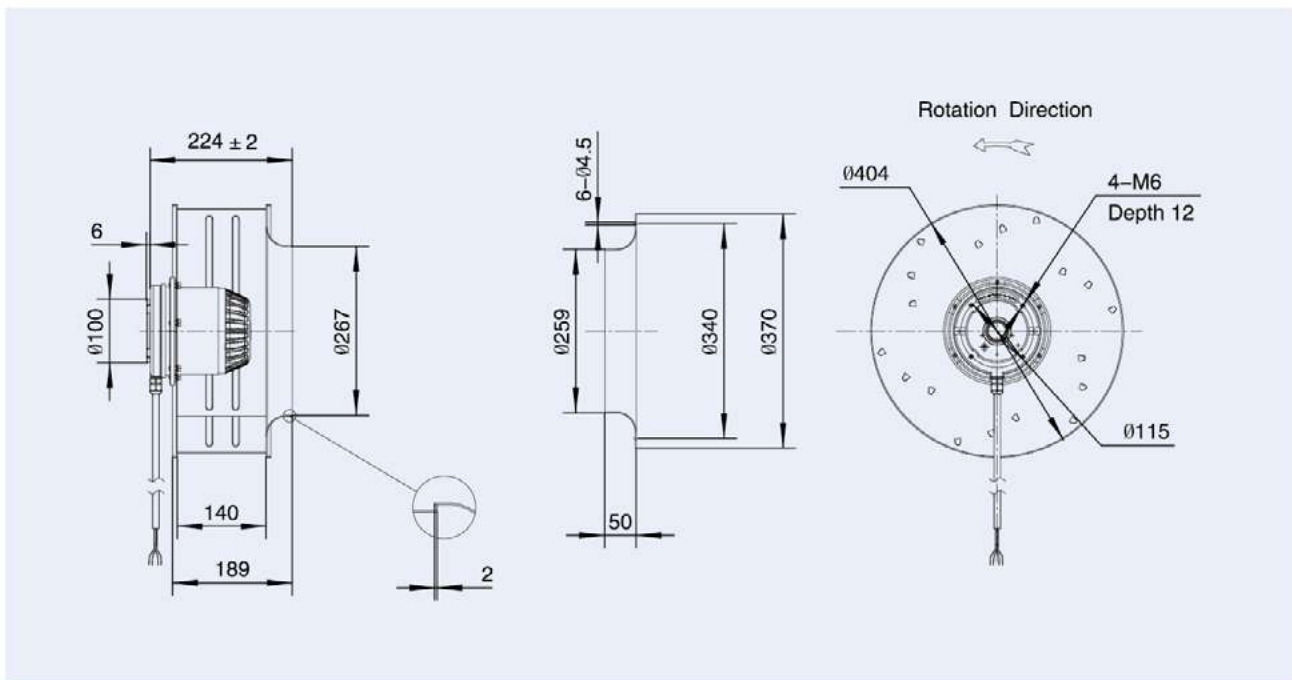

# LXF 交流后倾式离心风机 Backward Centrifugal Fans(AC)

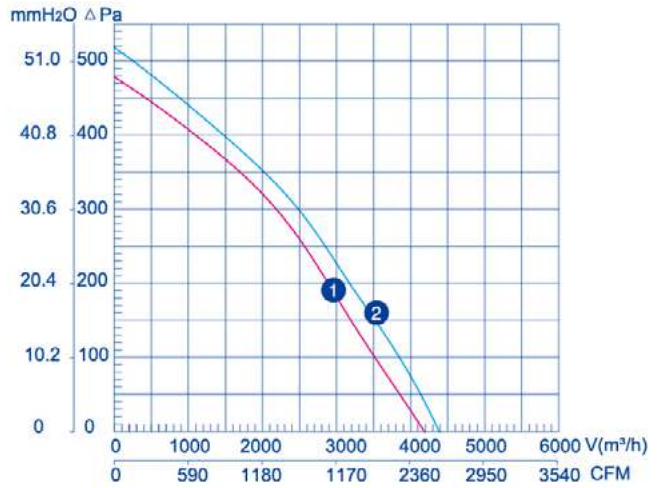

### 使用说明:

工作方式: S1  
 绝缘等级: B级/F级  
 环境温度: -25℃~+60℃  
 防护等级: IP44

### Instructions:

Operation mode: S1  
 Insulation class: B/F  
 Ambient temperature: -25℃~+60℃  
 Type of protection: IP44

Type 型号	Rated voltage 额定电压 V	Frequency 频率 Hz	Current 额定电流 A	Input power 输入功率 W	Rated speed 额定转速 r/min	Air Volume 额定风量 m³/h	Capacitance 电容 μF	Noise level 噪音 dBA	Net weight 净重 Kg	Curve 曲线
LXFB4D400/123-M137/050-****	380	50	0.7	410	1380	4300	\	74	9	②
LXFB4E400/123-M137/050-****	220	50	1.5	430	1350	4100	12	73	9	①

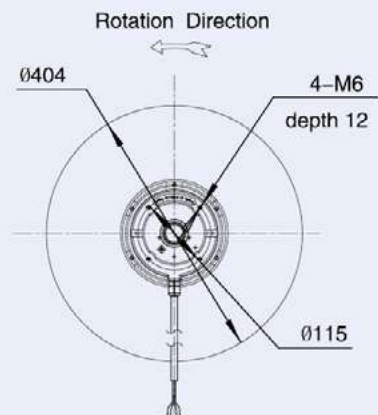
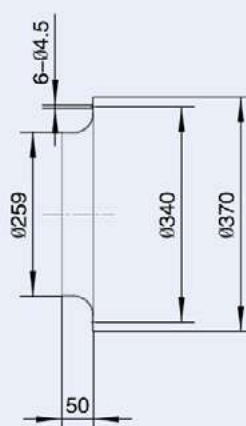
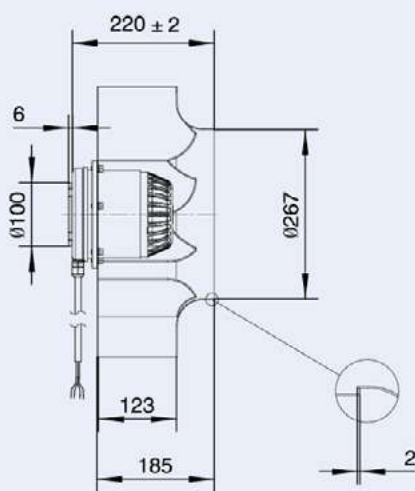

**LXF** 交流后倾式离心风机 **Backward Centrifugal Fans(AC)**

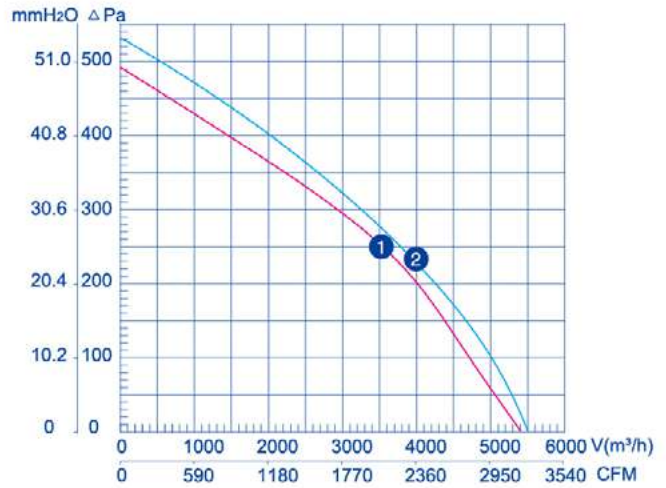

**使用说明:**

工作方式: S1  
 绝缘等级: B级/F级  
 环境温度: -25℃~+60℃  
 防护等级: IP44

**Instructions:**

Operation mode: S1  
 Insulation class: B/F  
 Ambient temperature: -25℃~+60℃  
 Type of protection: IP44

Type 型号	Rated voltage 额定电压 V	Frequency 频率 Hz	Current 额定电流 A	Input power 输入功率 W	Rated speed 额定转速 r/min	Air Volume 额定风量 m³/h	Capacitance 电容 μF	Noise level 噪音 dBA	Net weight 净重 kg	Curve 曲线
LXFB4D450/160-M137/070-****	380	50	1.05	510	1340	5500	/	76	12	②
LXFB4E450/160-M137/070-****	220	50	2.35	510	1300	5100	12	76	12	①

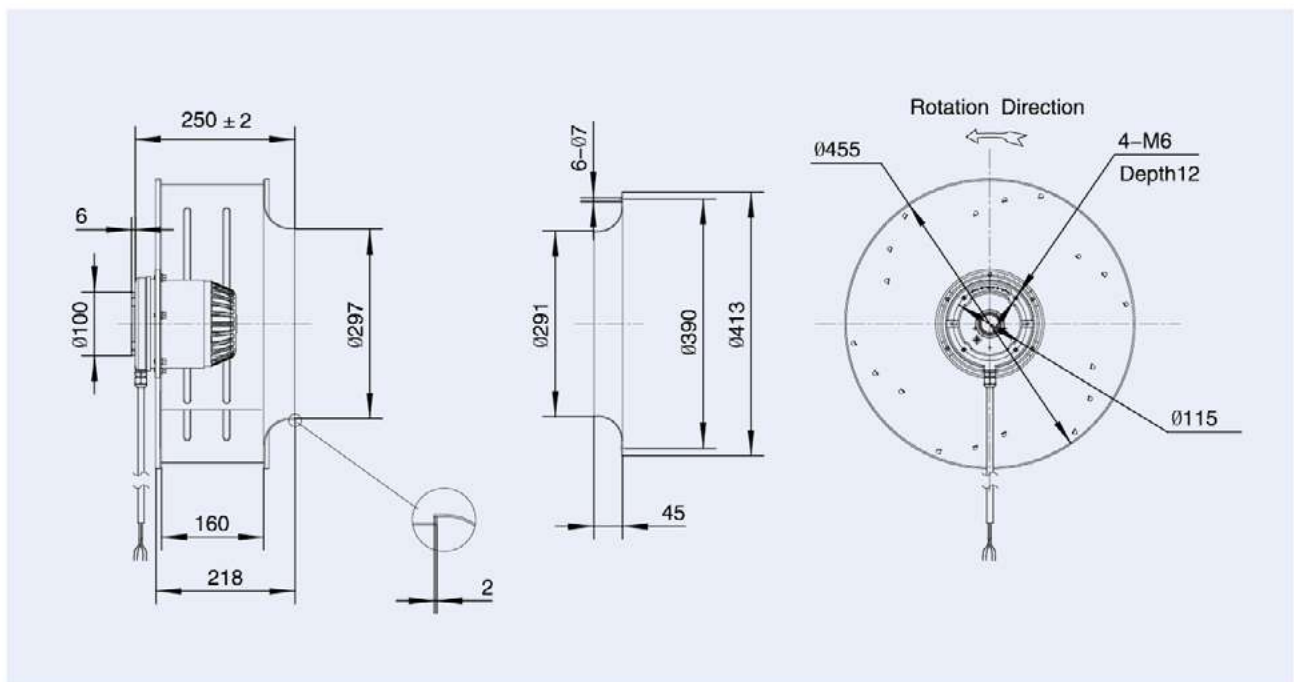

# LXF 交流后倾式离心风机 Backward Centrifugal Fans(AC)

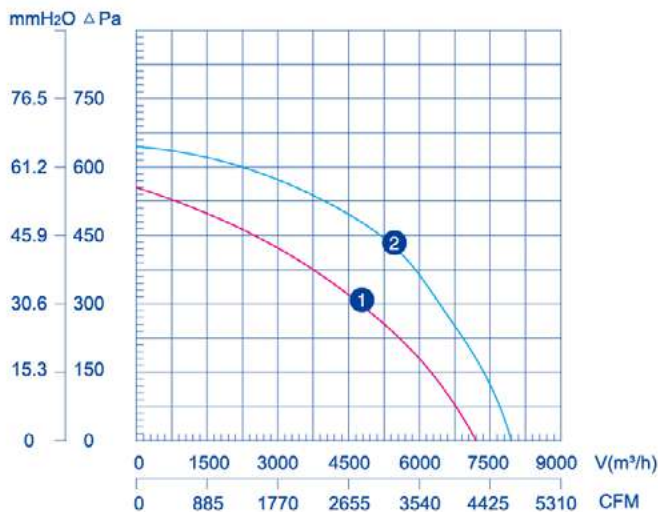

### 使用说明:

工作方式: S1  
 绝缘等级: B级/F级  
 环境温度: -25℃~+60℃  
 防护等级: IP44

### Instructions:

Operation mode: S1  
 Insulation class: B/F  
 Ambient temperature: -25℃~+60℃  
 Type of protection: IP44

Type 型号	Rated voltage 额定电压 V	Frequency 频率 Hz	Current 额定电流 A	Input power 输入功率 W	Rated speed 额定转速 r/min	Air Volume 额定风量 m <sup>3</sup> /h	Noise level 噪音 dBA	Net weight 净重 kg	Curve 曲线
LXFB4D500/180-M180/075-****	380 Δ	50	2.18	1070	1430	8000	80	20	②
	380 Y	50	1.48	880	1300	7000	78	20	①

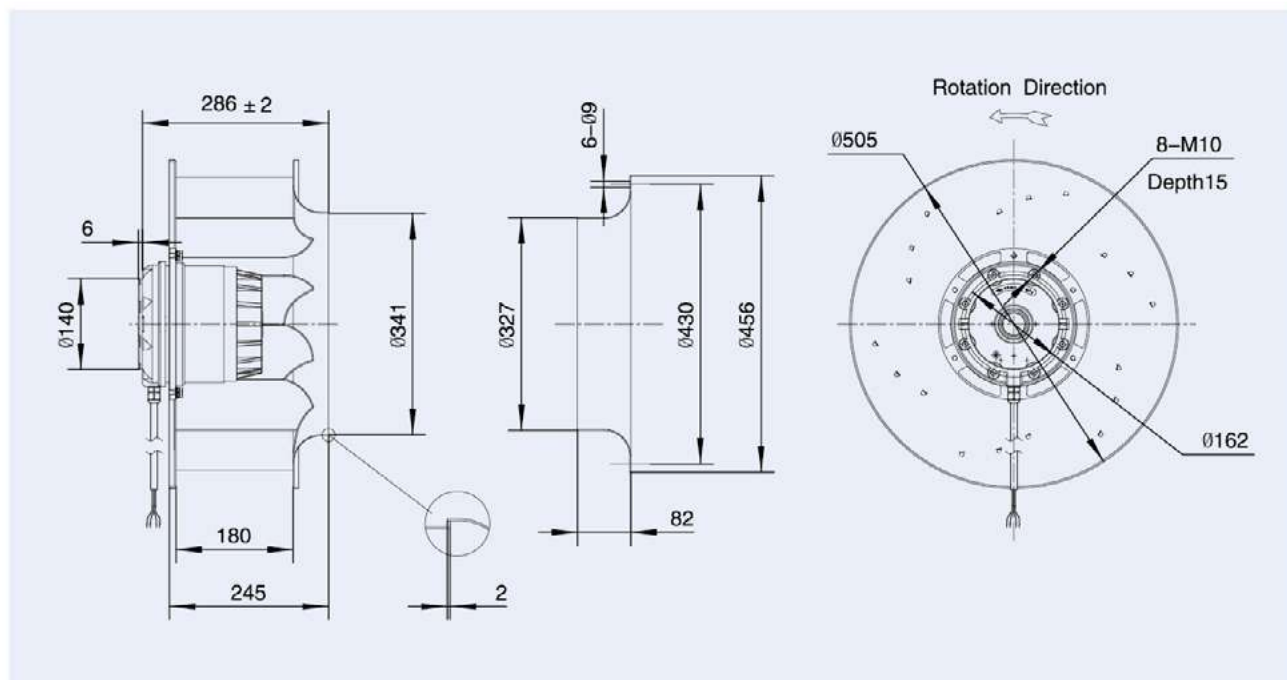

**LXF** 交流后倾式离心风机 **Backward Centrifugal Fans(AC)**

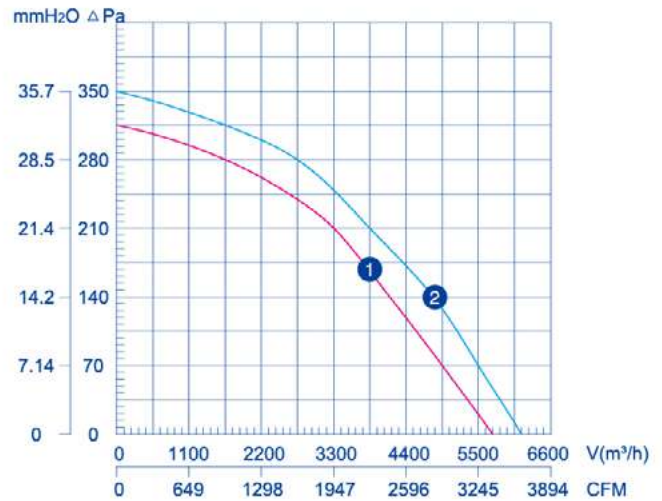

**使用说明:**

工作方式: S1  
绝缘等级: B级/F级  
环境温度: -25℃~+60℃  
防护等级: IP44

**Instructions:**

Operation mode: S1  
Insulation class: B/F  
Ambient temperature: -25℃~+60℃  
Type of protection: IP44

Type 型号	Rated voltage 额定电压 V	Frequency 频率 Hz	Current 额定电流 A	Input power 输入功率 W	Rated speed 额定转速 r/min	Air Volume 额定风量 m³/h	Noise level 噪音 dBA	Net weight 净重 kg	Curve 曲线
LXFB6D500/180-M180/075-****	380 Δ	50	1.00	340	970	6100	70	20	2
	380 Y	50	0.50	260	710	5700	68	20	1

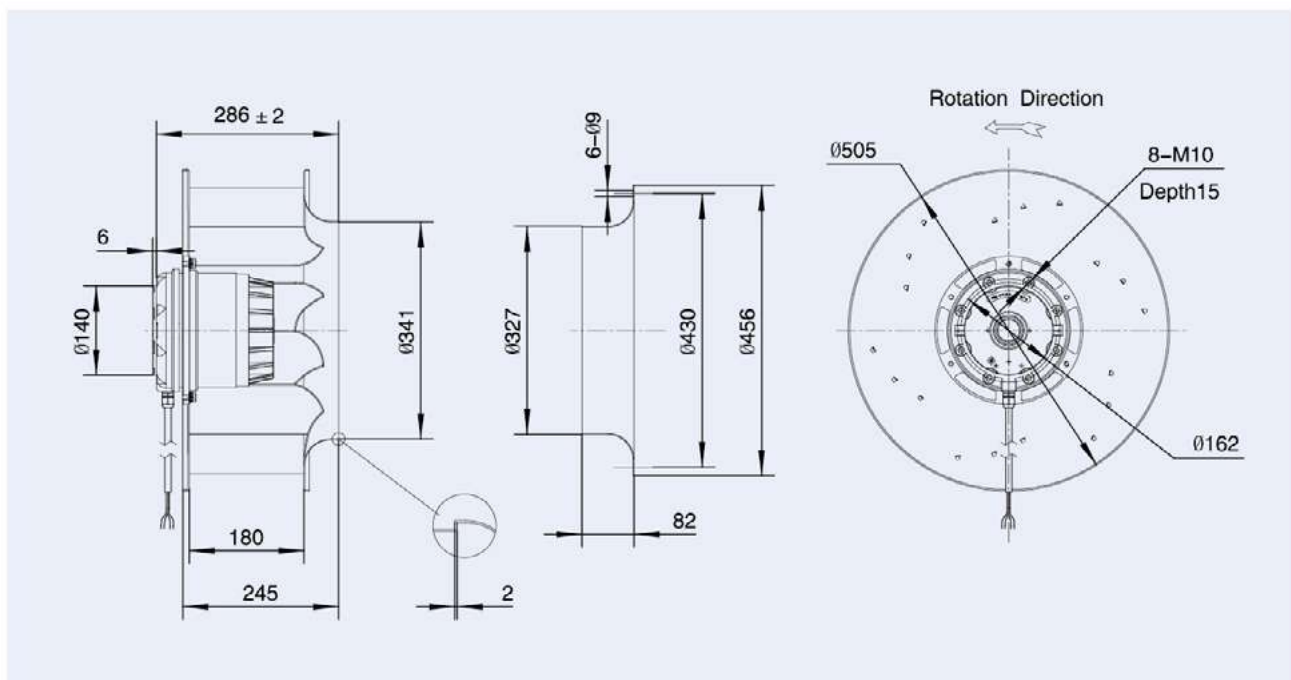

# LXF 交流后倾式离心风机 Backward Centrifugal Fans(AC)

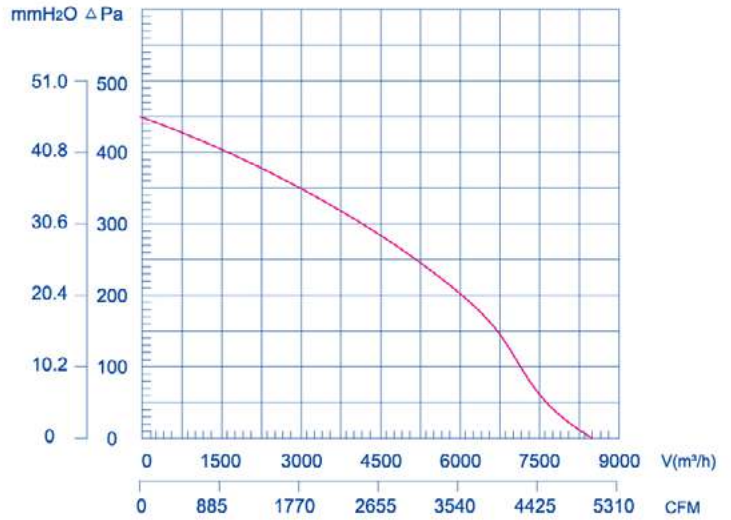

### 使用说明:

工作方式: S1  
 绝缘等级: B级/F级  
 环境温度: -25℃~+60℃  
 防护等级: IP44

### Instructions:

Operation mode: S1  
 Insulation class: B/F  
 Ambient temperature: -25℃~+60℃  
 Type of protection: IP44

Type 型号	Rated voltage 额定电压 V	Frequency 频率 Hz	Current 额定电流 A	Input power 输入功率 W	Rated speed 额定转速 r/min	Air Volume 额定风量 m³/h	Noise level 噪音 dBA	Net weight 净重 kg
LXFB6D560/155-M180/075-****	380	50	1.4	600	920	8500	72	27

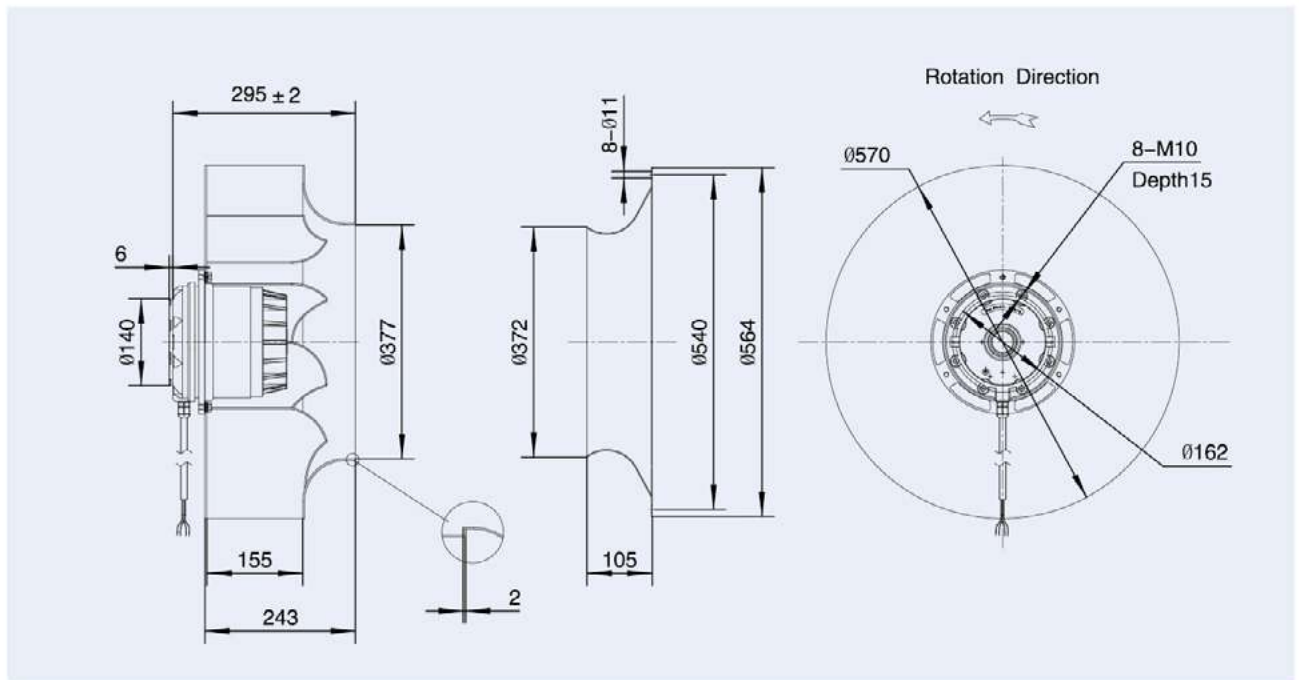



**LXF** 交流后倾式离心风机 **Backward Centrifugal Fans(AC)**

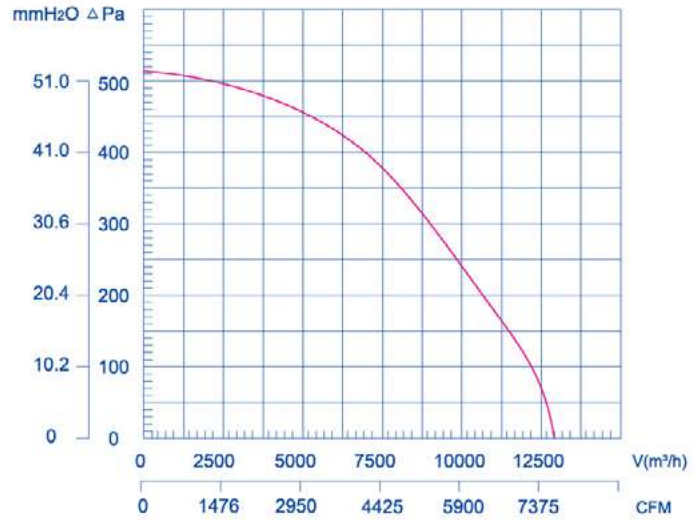

**使用说明:**

工作方式: S1  
绝缘等级: B级/F级  
环境温度: -25℃~+60℃  
防护等级: IP44

**Instructions:**

Operation mode: S1  
Insulation class: B/F  
Ambient temperature: -25℃~+60℃  
Type of protection: IP44

Type 型号	Rated voltage 额定电压 V	Frequency 频率 Hz	Current 额定电流 A	Input power 输入功率 W	Rated speed 额定转速 r/min	Air Volume 额定风量 m³/h	Noise level 噪音 dBA	Net weight 净重 kg
LXFB6D630/195-M180/105-****	380	50	3.0	1150	950	13000	78	30

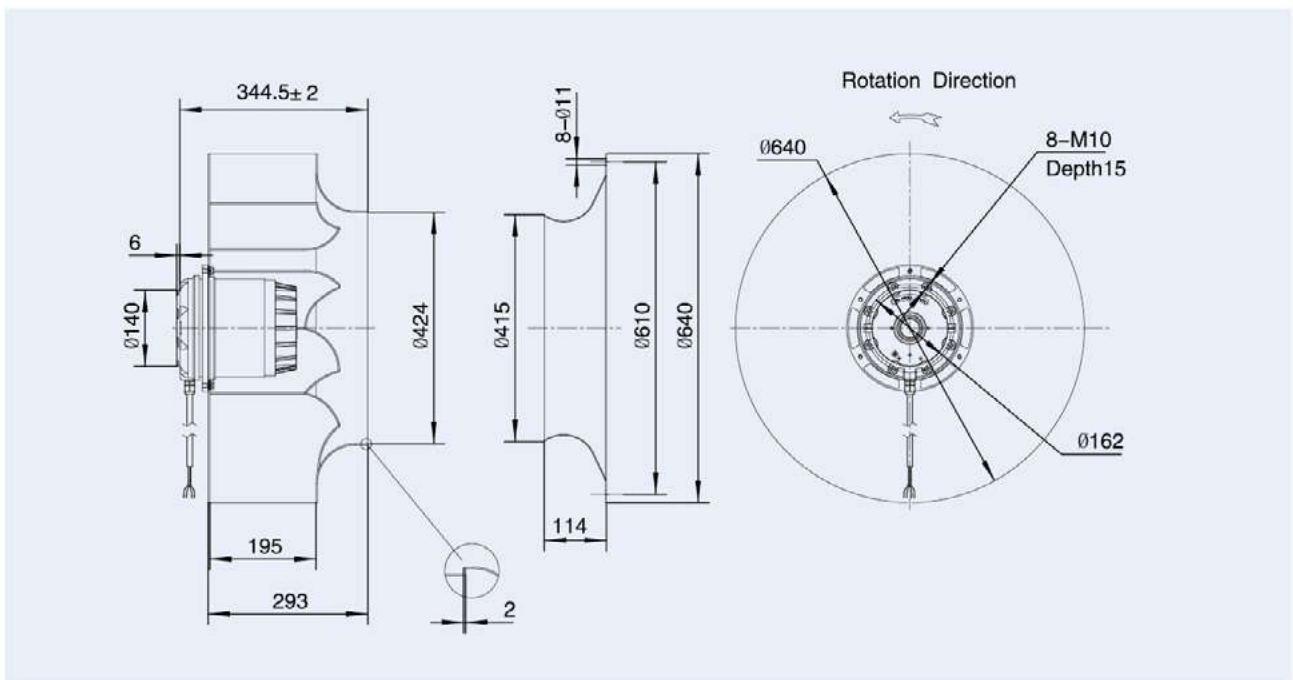

# LXF 交流后倾式离心风机 Backward Centrifugal Fans(AC)

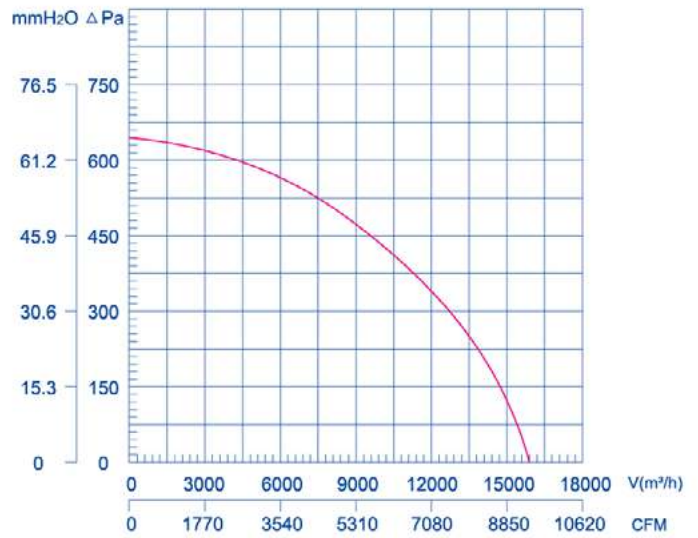

### 使用说明:

工作方式: S1  
 绝缘等级: B级/F级  
 环境温度: -25℃--+60℃  
 防护等级: IP44

### Instructions:

Operation mode: S1  
 Insulation class: B/F  
 Ambient temperature: -25℃--+60℃  
 Type of protection: IP44

Type 型号	Rated voltage 额定电压 V	Frequency 频率 Hz	Current 额定电流 A	Input power 输入功率 W	Rated speed 额定转速 r/min	Air Volume 额定风量 m³/h	Noise level 噪音 dBA	Net weight 净重 kg
LXFB6D710/219-M180/105-****	380	50	3.8	1900	910	22000	83	32

