

Data sheet

Thermostatic expansion valves

Type TGE 10, TGE 20 and TGE 40



TGE is a dedicated designed series of thermostatic expansion valves for all standard refrigerants.

The tight design meets the environmental demands for today and future.

Versions for non standard refrigerants can be produced to order.

Applications

- Water chillers
- Bus A/C
- Rooftop units
- Heat pumps
- Refrigerated containers
- Others A/C and refrigeration system

Features

- Refrigerants: R410A, R32, R452B, R454B, R22, R134a, R1234ze, R407F, R407A, R404A, R507, R407C and R290
- Capacity range: 3.5 – 52 TR / 12 – 182 kW for R410A
- Balance port design
- Biflow with expansion in both directions
- Low hysteresis
- Long lifetime for heat pump applications
- Mechanical connections types solder ODF, flare, MIO, ORFS are available
- Laser welded, stainless steel power element, capillary tube, and bulb
- MOP (Max. Operating Pressure) function is available
- Optional bleed function
- PS / MWP (maximum working pressure): 46 bar/ 667 psig
- Straightway flow
- Adjustable superheat setting
- Cylindrical bulb and patented bulb strap design
- Compliance with ATEX hazard zone 2
- UL certified



Data sheet | Thermostatic expansion valves, type TGE 10, TGE 20, TGE 40

Refrigerants: Refrigerants: R410A, R32, R452B, R454B, R22, R134a, R1234ze, R407F, R407A, R404A, R507, R407C and R290.
For other refrigerants, please contact Danfoss.
Note: this product is approved for R290 by ignition source assessment in accordance to standard EN13463-1.

Approvals



Technical data

Max. temperature on thermostatic element: MAH : 150 °C / 302 °F
K : 150 °C / 302 °F
N : 100 °C / 210 °F

Max. temperature on valve body: 110 °C / 230 °F

Max. working pressure: 46 bar / 667 psig.

Max. test pressure: 51 bar / 740 psig.

Standard evaporating temperature ranges

Charge	Temperature range
MAH	-30 – 15 °C / -22 – 60 °F
N	-40 – 10 °C / -40 – 50 °F without MOP
K	-25 – 10 °C, MOP 15 °C / -15 – 50 °F, MOP 60 °F

Max. operating pressure ¹⁾

Refrigerant	Range K: -25 – 10 °C / -15 – 50 °F, MOP +15 °C / +60 °F
	MOP point in evaporating pressure p _e
R410A	11.4 bar / 165 psig
R22	6.9 bar / 100 psig
R134a	3.8 bar / 55 psig
R407C	6.6 bar / 95 psig
R404A/ R507	8.3 bar / 120 psig

¹⁾ MOP for R32, R452B, R454B, R1234ze, R407F, R407A and R290 please contact Danfoss for more info.

Connections

Type	Inlet solder ODF [inch]	Inlet solder ODF [mm]	Outlet solder ODF [inch]	Outlet solder ODF [mm]
TGE 10	3/8, 1/2, 5/8, 7/8	10, 12, 16, 22	5/8, 7/8, 1 1/8	16, 22, 28
TGE 20	5/8, 7/8, 1 1/8	16, 22, 28	5/8, 7/8, 1 1/8, 1 3/8	16, 22, 28, 35
TGE 40	7/8, 1 1/8	22, 28	7/8, 1 1/8, 1 3/8	22, 28, 35

Capillary tube length

Type	Capillary tube length	
TGE 10 / TGE 20	1.5 m	59 inch
TGE 40	3 m	118 inch

Valve options

In addition to the standard programme, variants of following options may be available:

- Refrigerants
- Evaporating temperature range
- MOP point
- Static superheat setting (0K – 8K / 0 – 14.4 °F)
- Mechanical connections
- Bleed function (15% or 30%)

Please contact your nearest Danfoss sales office to discuss valve options.

Design and function

- 1. Bulb with capillary tube
- 2. Thermostatic element
- 3. Thrust pad
- 4. Push pin seal
- 5. Cone
- 6. Valve body
- 7. Static SH adjustment spindle
- 8. Protective cap

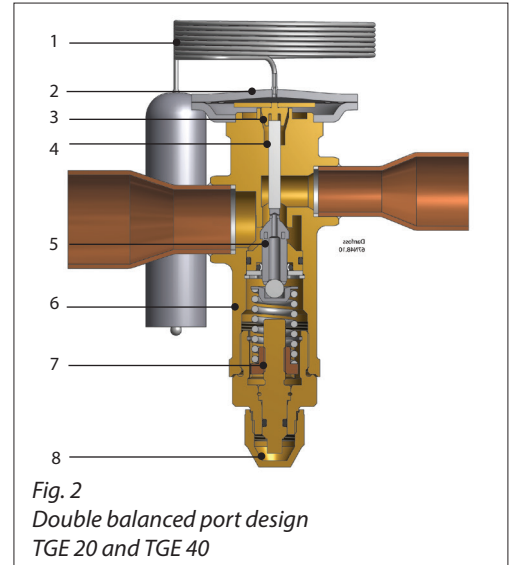
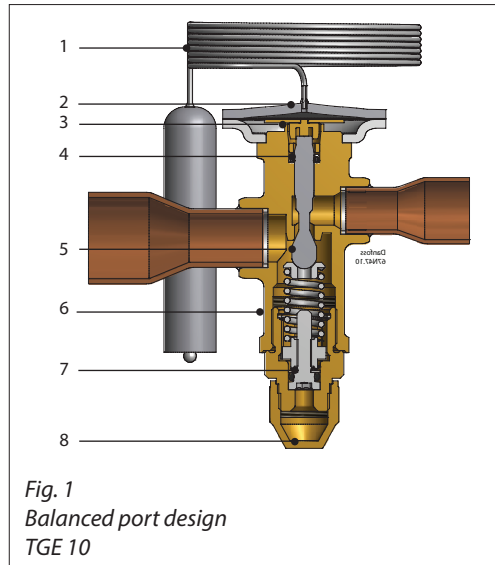

Balanced port design and advantage

The TGE series of thermostatic expansion valves have balanced port design. Balanced port design prevents changes in pressure drop across the valve from influencing operation and provides excellent control on applications having widely varying operating conditions. Balanced port TXV's are recommended in refrigeration and air conditioning systems with any combinations of these conditions:

- 1) Widely varying head pressures
- 2) Widely varying evaporator loads
- 3) Widely varying pressure drop across the TXV
- 4) Fluctuating or extremely low liquid temperatures
- 5) Intermittent liquid line flash gas

TGE valves are designed for biflow operations. TGE 10 has minor capacity reduction in reverse flow.

The central push pin is fitted with a robust seal (Pos 4) that ensures maximum tightness for the life of the valve.

Static superheat (SS) can be adjusted by the setting spindle (Pos 6), see fig. 1. The standard superheat setting (SS) is 4K / 7.2 °F and adjustable for 0 – 8K / 0 – 14.4 °F.

SS = Static Superheat
 OS = Opening Superheat
 SH = SS + OS = total superheat

Example:
 Static superheat SS = 4K / 7.2 °F
 Opening superheat OS = 4K / 7.2 °F
 The opening superheat is 4K / 7.2 °F, i.e. from the point the valve begins to open up to rated capacity. Opening superheat is determined by the design and cannot be changed.

Total superheat SH = SS + OS
 SH = 4 + 4 = 8K / 14.4 °F

Total superheat SH can be altered by changing SS (by using the setting spindle).

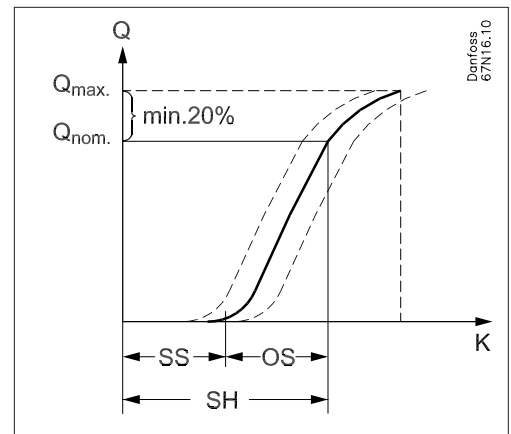

Application

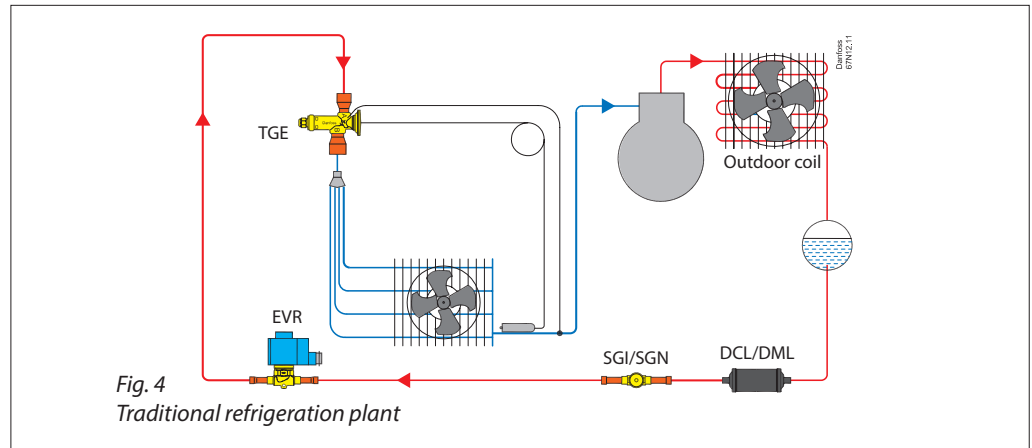

Fig. 4
Traditional refrigeration plant

Fig. 4 A diagram of a traditional refrigeration plant where TGE is used for flow in one direction only.

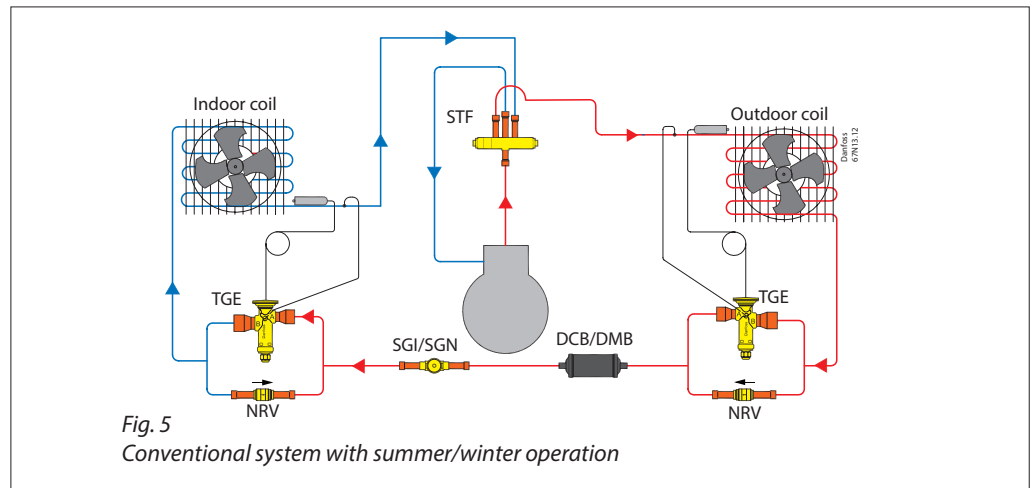

Fig. 5
Conventional system with summer/winter operation

Fig. 5 A conventional split heat pump system shown in cooling mode. This system has two TGE thermostatic expansion valves with fixed direction flow. An NRV check valve is placed in series with each TGE to allow liquid refrigerant to bypass when flow is opposite the TXV fixed direction.

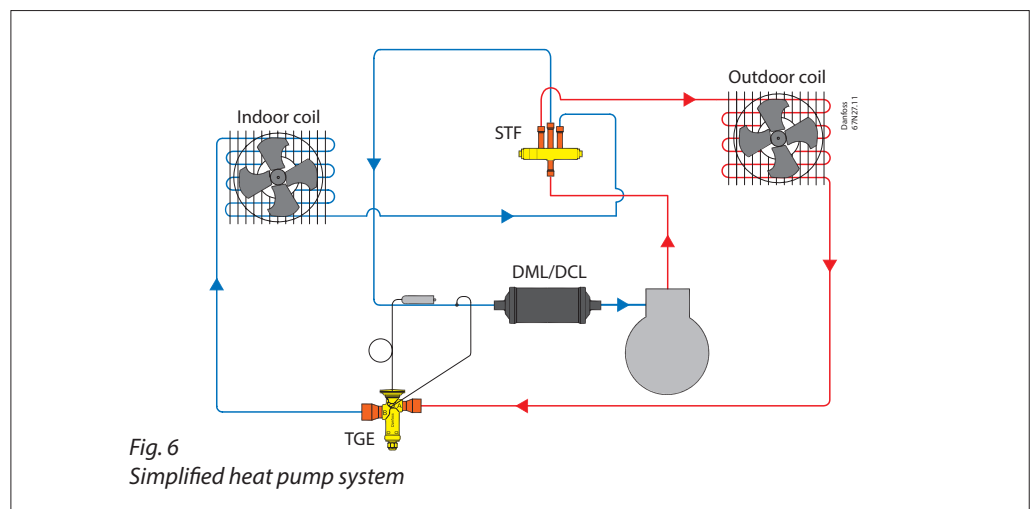

Fig. 6
Simplified heat pump system

Fig. 6 A heat pump system similar to that in fig. 5 but with a more compact design, where the distance between evaporator and condenser is very short. This system has only one bi-flow TGE valve metering liquid refrigerant effectively in both directions. Changeover is by means of a 4-way valve. A suction filter drier is often placed in suction lines just before the compressor. The normal flow direction of TGE is determined by the primary function, i.e. cooling or heating.



Data sheet | Thermostatic expansion valves, type TGE 10, TGE 20, TGE 40

Identification

The valve is fitted with a product label (on top of the diaphragm) which holds information as follows:

- TGE = Valve type
- 9 TR = Rated capacity Q in TR
- 32 kW = Rated capacity Q in kW
- R410A = Refrigerant
- 25 – 10 °C / -15 – 50 °F = Evaporating temperature range
- 067N3006 = Code number
- MOP 165 = Max. operating pressure 165 psig
- PS 46 bar / MWP 667 psig = Max. working pressure in bar and psig

- BE3216C: BE = China
- 32 = week
- 16 = 2016
- C = wednesday

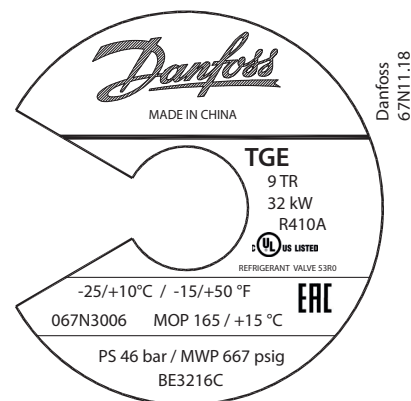

Rated capacity ²⁾

Valve type	Orifice no.	Range N, K, MAH																							
		R410A		R32		R452B ⁴⁾		R454B ⁴⁾		R22		R134a		R1234ze		R407F		R407A		R404A / R507		R407C		R290	
		KW	TR	KW	TR	KW	TR	KW	TR	KW	TR	KW	TR	KW	TR	KW	TR	KW	TR	KW	TR	KW	TR	KW	TR
TGE 10	3	12	3.5	18	5	12	3.5	14	4	10	3	6	1.5	5	1.5	10	3	9	2.5	7	2	9	2.5	10	3
	4	16	4.5	24	7	16	4.5	19	5.5	14	4	8	2.5	7	2	14	4	12	3.5	9	2.5	13	3.5	14	4
	6	24	6.5	35	10	24	6.5	28	8	20	6	12	3.5	10	3	20	6	17	5	14	4	19	5	19	5
	8	32	9	47	13	32	9	39	11	27	7.5	17	4.5	14	4	27	7.5	23	6.5	18	5	25	7	25	7
	9	37	11	54	15	38	11	46	13	32	9	20	5.5	16	4.5	32	9	28	8	21	6	30	8.5	32	9
	11	45	13	68	19	46	13	56	16	38	11	24	7	20	5.5	40	11	34	10	26	7.5	36	10	36	10
	12.5	50	14	74	21	50	14	60	17	43	12	29	8	22	6	43	12	39	11	31	9	39	11	44	12
TGE 20	16	60	17	87	25	60	17	70	20	50	14	35	9.5	27	7.5	50	14	46	13	35	10	49	14	50	14
	12.5	54	15	81	23	55	15	67	19	43	12	29	8	22	6	46	13	39	11	31	9	42	12	44	12
	16	68	19	102	29	68	19	81	23	54	15	37	10	27	7.5	57	16	50	14	39	11	53	15	54	15
	20	79	23	120	34	81	23	98	28	63	18	44	12	31	8.5	67	19	59	17	45	13	62	18	63	18
TGE 40	21 ³⁾	91	26	135	38	98	28	116	33	75	21	51	15	39	11	82	23	72	21	53	15	77	22	75	21
	26	110	31	165	47	117	33	133	38	92	26	61	17	49	14	95	27	80	23	64	18	84	24	92	26
	30	125	35	187	53	134	38	151	43	104	30	70	20	57	16	108	31	91	26	72	21	95	27	106	30
	40	161	46	236	67	172	49	193	55	134	38	87	25	72	20	138	39	116	33	92	26	121	34	133	38
TGE 40	42	182	52	273	78	208	59	229	65	148	42	102	29	81	23	165	47	140	40	105	30	148	42	152	43

²⁾ The rated capacity is based on:
 Evaporating temperature t_e : 4.4 °C / 40 °F
 Condensing temperature t_c : 38 °C / 100 °F
 Refrigerant temperature ahead of valve t_i : 37 °C / 98 °F

³⁾ Contact Danfoss for more information
⁴⁾ New sales code numbers are on request.

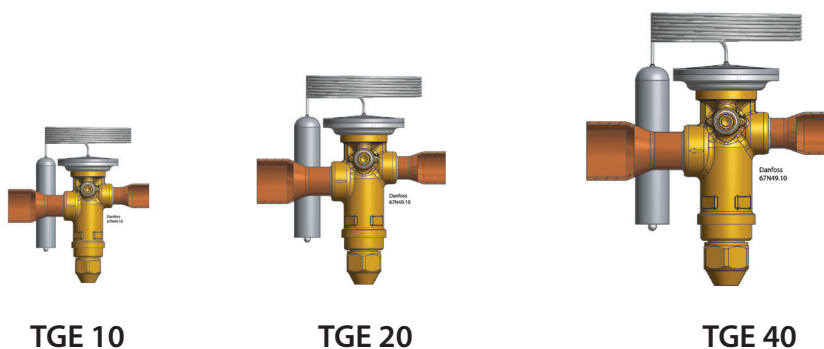



Data sheet | Thermostatic expansion valves, type TGE 10, TGE 20, TGE 40

Ordering

Only solder versions, connection size 28 mm / 1 1/8 in. or below are approved for flammable refrigerants.

Range N -40 – 10 °C / -40 –50 °F, OS = 4 K / 7.2 °F

R410A/R32

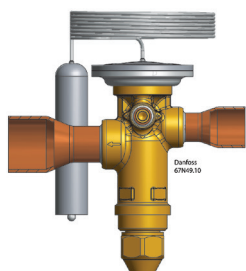

Valve type	Orifice no.	Rated capacity R410A		Rated capacity R32		Connections solder ODF		Code no. Multi pack
		[KW]	[TR]	[KW]	[TR]	Inlet x Outlet [inch]	Pressure equalization [inch]	
TGE 10	3	12	3.5	18	5	3/8 x 3/8	1/4	067N3150
TGE 10	3	12	3.5	18	5	1/2 x 3/8	1/4	067N3151
TGE 10	4	16	4.5	24	7	1/2 x 7/8	1/4	067N3152
TGE 10	6	24	6.5	35	10	1/2 x 3/8	1/4	067N3153
TGE 10	6	24	6.5	35	10	1/2 x 7/8	1/4	067N3154
TGE 10	6	24	6.5	35	10	5/8 x 7/8	1/4	067N3155
TGE 10	8	32	9	47	13	1/2 x 3/8	1/4	067N3293
TGE 10	8	32	9	47	13	5/8 x 7/8	1/4	067N3156
TGE 10	9	37	11	54	15	5/8 x 7/8	1/4	067N3296
TGE 10	11	45	13	68	19	5/8 x 7/8	1/4	067N3157
TGE 10	12.5	50	14	74	21	5/8 x 7/8	1/4	067N3410
TGE 20	12.5	54	15	81	23	5/8 x 7/8	1/4	067N3159
TGE 40	26	110	31	165	47	1 1/8 x 1 1/8	1/4	067N3234

The rated capacity is based on:
 Evaporating temperature t_e : 4.4 °C / 40 °F
 Condensing temperature t_c : 38 °C / 100 °F
 Refrigerant temperature ahead of valve t_1 : 37 °C / 98 °F

Range N -40 – 10 °C / -40 –50 °F, OS = 4 K / 7.2 °F

R410A

Valve type	Orifice no.	Rated capacity		Connections solder ODF		Code no. Multi pack
		[KW]	[TR]	Inlet x Outlet [inch]	Pressure equalization [inch]	
TGE 10	11	45	13	5/8 x 1 1/8	1/4	067N3158
TGE 10	16	60	17	7/8 x 1 1/8	1/4	067N3411
TGE 20	12.5	54	15	5/8 x 1 1/8	1/4	067N3160
TGE 20	12.5	54	15	7/8 x 7/8	1/4	067N3231
TGE 20	12.5	54	15	7/8 x 1 1/8	1/4	067N3232
TGE 20	16	68	19	5/8 x 1 1/8	1/4	067N3161
TGE 20	16	68	19	7/8 x 1 1/8	1/4	067N3162
TGE 20	20	79	23	7/8 x 1 1/8	1/4	067N3163
TGE 20	20	79	23	7/8 x 1 3/8	1/4	067N3164
TGE 40	26	110	31	7/8 x 1 3/8	1/4	067N3165
TGE 40	26	110	31	1 1/8 x 1 3/8	1/4	067N3166
TGE 40	30	125	35	1 1/8 x 1 3/8	1/4	067N3168
TGE 40	40	161	46	1 1/8 x 1 3/8	1/4	067N3169
TGE 40	42	182	52	1 1/8 x 1 3/8	1/4	067N3400

The rated capacity is based on:
 Evaporating temperature t_e : 4.4 °C / 40 °F
 Condensing temperature t_c : 38 °C / 100 °F
 Refrigerant temperature ahead of valve t_1 : 37 °C / 98 °F

Ordering

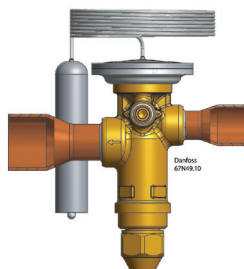

Range K -25 – 10 °C / -15 – 50 °F with MOP 15 °C / 60 °F, OS = 4 K / 7.2 °F

R410A

Valve type	Orifice no.	Rated capacity		Connections solder ODF		Code no. Multi pack
		[KW]	[TR]	Inlet x Outlet [inch]	Pressure equalization [inch]	
TGE 10	3	12	3.5	3/8 x 5/8	1/4	067N3000
TGE 10	3	12	3.5	1/2 x 5/8	1/4	067N3001
TGE 10	4	16	4.5	1/2 x 7/8	1/4	067N3002
TGE 10	6	24	6.5	1/2 x 5/8	1/4	067N3003
TGE 10	6	24	6.5	5/8 x 7/8	1/4	067N3005
TGE 10	8	32	9.0	5/8 x 7/8	1/4	067N3006
TGE 10	9	37	11	5/8 x 7/8	1/4	067N3340
TGE 10	11	45	13	5/8 x 7/8	1/4	067N3007
TGE 10	11	45	13	5/8 x 1 1/8	1/4	067N3008
TGE 10	12.5	50	14	5/8 x 1 1/8	1/4	067N3402
TGE 10	16	60	17	5/8 x 1 1/8	1/4	067N3401
TGE 20	12.5	54	15	5/8 x 7/8	1/4	067N3009
TGE 20	12.5	54	15	5/8 x 1 1/8	1/4	067N3010
TGE 20	16	68	19	5/8 x 1 1/8	1/4	067N3011
TGE 20	16	68	19	7/8 x 1 1/8	1/4	067N3012
TGE 20	20	79	23	7/8 x 1 1/8	1/4	067N3013
TGE 40	26	110	31	7/8 x 1 1/8	1/4	067N3135
TGE 40	26	110	31	7/8 x 1 3/8	1/4	067N3015
TGE 40	30	125	35	1 1/8 x 1 3/8	1/4	067N3018
TGE 40	40	161	46	1 1/8 x 1 3/8	1/4	067N3019
TGE 40	42	182	52	1 1/8 x 1 3/8	1/4	067N3341

The rated capacity is based on:
 Evaporating temperature t_e : 4.4 °C / 40 °F
 Condensing temperature t_c : 38 °C / 100 °F
 Refrigerant temperature ahead of valve t_1 : 37 °C / 98 °F

Range MAH -30 – 15 °C / -22 – 60 °F with anti hunting charge, OS = 4 K / 7.2 °F

R410A

Valve type	Orifice no.	Rated capacity		Connections solder ODF		Code no. Multi pack
		[KW]	[TR]	Inlet x Outlet [inch]	Pressure equalization [inch]	
TGE 10	3	12	3.5	1/2 x 5/8	1/4	067N9201
TGE 10	4	16	4.5	1/2 x 7/8	1/4	067N9202
TGE 10	6	24	6.5	1/2 x 5/8	1/4	067N9203
TGE 10	6	24	6.5	5/8 x 7/8	1/4	067N9200
TGE 10	8	32	9	5/8 x 7/8	1/4	067N9206
TGE 10	9	37	11	5/8 x 7/8	1/4	067N9287
TGE 10	11	45	13	5/8 x 7/8	1/4	067N9207
TGE 10	12.5	50	14	5/8 x 7/8	1/4	067N9509
TGE 10	16	60	17	7/8 x 1 1/8	1/4	067N9512
TGE 20	12.5	54	15	5/8 x 7/8	1/4	067N9209
TGE 20	12.5	54	15	5/8 x 1 1/8	1/4	067N9210
TGE 20	16	68	19	7/8 x 1 1/8	1/4	067N9212
TGE 20	20	79	23	7/8 x 1 1/8	1/4	067N9213
TGE 40	26	110	31	7/8 x 1 3/8	1/4	067N9215
TGE 40	26	110	31	1 1/8 x 1 3/8	1/4	067N9216
TGE 40	30	125	35	1 1/8 x 1 3/8	1/4	067N9218
TGE 40	40	161	46	1 1/8 x 1 3/8	1/4	067N9219
TGE 40	42	182	52	1 1/8 x 1 3/8	1/4	067N9289

The rated capacity is based on:
 Evaporating temperature t_e : 4.4 °C / 40 °F
 Condensing temperature t_c : 38 °C / 100 °F
 Refrigerant temperature ahead of valve t_1 : 37 °C / 98 °F

Ordering

Range N -40 – 10 °C / -40 –50 °F, OS = 4 K / 7.2 °F

R22/R407C ¹⁾

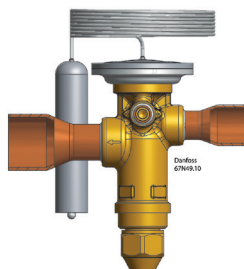

Valve type	Orifice no.	Rated capacity		Connections solder ODF Inlet x Outlet		Pressure equalization		Code no. Multi pack
		[KW]	[TR]	[inch]	[mm]	[inch]	[mm]	
TGE 10	3	10	3	3/8 x 3/8	–	1/4	–	067N2150
TGE 10	3	10	3	1/2 x 3/8	–	1/4	–	067N2151
TGE 10	4	14	4	1/2 x 7/8	–	1/4	–	067N2152
TGE 10	6	20	6	1/2 x 3/8	–	1/4	–	067N2153
TGE 10	6	20	6	1/2 x 7/8	–	1/4	–	067N2154
TGE 10	6	20	6	–	12 x 22	–	6	067N2194
TGE 10	6	20	6	–	16 x 16	–	6	067N2263
TGE 10	6	20	6	5/8 x 7/8	–	1/4	–	067N2155
TGE 10	8	27	7.5	5/8 x 7/8	–	1/4	–	067N2156
TGE 10	8	27	7.5	–	16 x 22	–	6	067N2196
TGE 10	9	32	9	5/8 x 7/8	–	1/4	–	067N2460
TGE 10	9	32	9	–	16 x 22	–	6	067N2281
TGE 10	11	38	11	5/8 x 7/8	–	1/4	–	067N2157
TGE 10	11	38	11	–	16 x 22	–	6	067N2197
TGE 10	11	38	11	5/8 x 1 1/8	–	1/4	–	067N2158
TGE 10	11	38	11	–	16 x 28	–	6	067N2198
TGE 10	12.5	43	12	5/8 x 7/8	–	1/4	–	067N2720
TGE 10	16	50	14	5/8 x 1 1/8	–	1/4	–	067N2721
TGE 10	16	50	14	7/8 x 1 1/8	–	1/4	–	067N2722
TGE 20	12.5	43	12	5/8 x 7/8	–	1/4	–	067N2159
TGE 20	12.5	43	12	5/8 x 1 1/8	–	1/4	–	067N2160
TGE 20	12.5	43	12	–	16 x 28	–	6	067N2200
TGE 20	16	54	15	5/8 x 7/8	–	1/4	–	067N2255
TGE 20	16	54	15	5/8 x 1 1/8	–	1/4	–	067N2161
TGE 20	16	54	15	7/8 x 1 1/8	–	1/4	–	067N2162
TGE 20	20	63	18	7/8 x 1 1/8	–	1/4	–	067N2163
TGE 20	20	63	18	7/8 x 1 3/8	–	1/4	–	067N2164
TGE 40	26	92	26	7/8 x 1 1/8	–	1/4	–	067N2251
TGE 40	26	92	26	7/8 x 1 3/8	–	1/4	–	067N2165
TGE 40	30	104	30	7/8 x 1 3/8	–	1/4	–	067N2167
TGE 40	30	104	30	1 1/8 x 1 3/8	–	1/4	–	067N2168
TGE 40	40	134	38	1 1/8 x 1 3/8	–	1/4	–	067N2169
TGE 40	42	148	42	1 1/8 x 1 3/8	–	1/4	–	067N2283

The rated capacity is based on:
 Evaporating temperature t_e : 4.4 °C / 40 °F
 Condensing temperature t_c : 38 °C / 100 °F
 Refrigerant temperature ahead of valve t_i : 37 °C / 98 °F

¹⁾ For R407C plants, please select valves from the dedicated R407C program.

Ordering

Range K -25 – 10 °C / -15 – 50 °F with MOP 15 °C / 60 °F,
OS = 4 K / 7.2 °F

R22/R407C ¹⁾

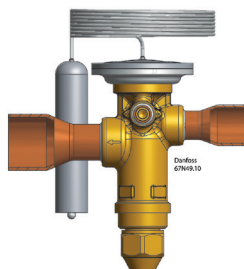

Valve type	Orifice no.	Rated capacity		Connections solder ODF		Code no. Multi pack
		[KW]	[TR]	Inlet x Outlet [inch]	Pressure equalization [inch]	
TGE 10	3	10	3	3/8 x 5/8	1/4	067N2000
TGE 10	3	10	3	1/2 x 5/8	1/4	067N2001
TGE 10	4	14	4	1/2 x 7/8	1/4	067N2002
TGE 10	6	20	6	1/2 x 3/4	1/4	067N2003
TGE 10	6	20	6	5/8 x 7/8	1/4	067N2005
TGE 10	8	27	7.5	5/8 x 1/2	1/4	067N2006
TGE 10	9	32	9	5/8 x 3/4	1/4	067N2415
TGE 10	11	38	11	5/8 x 7/8	1/4	067N2007
TGE 10	11	38	11	5/8 x 1 1/8	1/4	067N2008
TGE 10	12.5	43	12	5/8 x 3/4	1/4	067N2700
TGE 10	16	50	14	7/8 x 1 1/8	1/4	067N2701
TGE 20	12.5	43	12	5/8 x 7/8	1/4	067N2009
TGE 20	12.5	43	12	5/8 x 1 1/8	1/4	067N2010
TGE 20	16	54	15	5/8 x 1 1/8	1/4	067N2011
TGE 20	16	54	15	7/8 x 1 1/8	1/4	067N2012
TGE 20	20	63	18	7/8 x 1 1/8	1/4	067N2013
TGE 20	20	63	18	7/8 x 1 3/8	1/4	067N2014
TGE 40	26	92	26	7/8 x 1 3/8	1/4	067N2015
TGE 40	26	92	26	1 1/8 x 1 3/8	1/4	067N2016
TGE 40	30	104	30	7/8 x 1 3/8	1/4	067N2017
TGE 40	30	104	30	1 1/8 x 1 3/8	1/4	067N2018
TGE 40	40	134	38	1 1/8 x 1 3/8	1/4	067N2019

The rated capacity is based on:
 Evaporating temperature t_e : 4.4 °C / 40 °F
 Condensing temperature t_c : 38 °C / 100 °F
 Refrigerant temperature ahead of valve t_1 : 37 °C / 98 °F

¹⁾ For R407C plants, please select valves from the dedicated R407C program.

Range MAH -30 – 15 °C / -22 – 60 °F with anti hunting charge,
OS = 4 K / 7.2 °F

R22/R407C ¹⁾

Valve type	Orifice no.	Rated capacity		Connections solder ODF		Code no. Multi pack
		[KW]	[TR]	Inlet x Outlet [inch]	Pressure equalization [inch]	
TGE 10	6	20	6	1/2 x 7/8	1/4	067N9404
TGE 10	8	27	7.5	5/8 x 7/8	1/4	067N9406
TGE 10	11	38	11	5/8 x 7/8	1/4	067N9407
TGE 20	12.5	43	12	5/8 x 7/8	1/4	067N9409
TGE 20	16	54	15	7/8 x 1 1/8	1/4	067N9412
TGE 20	20	63	18	7/8 x 1 3/8	1/4	067N9413
TGE 40	26	92	26	7/8 x 1 3/8	1/4	067N9415
TGE 40	30	104	30	1 1/8 x 1 3/8	1/4	067N9418
TGE 40	40	134	38	1 1/8 x 1 3/8	1/4	067N9419

The rated capacity is based on:
 Evaporating temperature t_e : 4.4 °C / 40 °F
 Condensing temperature t_c : 38 °C / 100 °F
 Refrigerant temperature ahead of valve t_1 : 37 °C / 98 °F

¹⁾ For R407C plants, please select valves from the dedicated R407C program.

Ordering

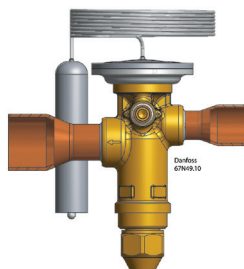

Range N -40 – 10 °C / -40 –50 °F, OS = 4 K / 7.2 °F

R134a

Valve type	Orifice no.	Rated capacity		Connections solder ODF				Code no. Multi pack
		[KW]	[TR]	Inlet x Outlet		Pressure equalization		
				[inch]	[mm]	[inch]	[mm]	
TGE 10	3	6	1.5	3/8 x 3/8	-	1/4	-	067N5150
TGE 10	3	6	1.5	-	12 x 16	-	6	067N5191
TGE 10	4	8	2.5	1/2 x 7/8	-	1/4	-	067N5152
TGE 10	4	8	2.5	-	12 x 22	-	6	067N5192
TGE 10	6	12	3.5	1/2 x 5/8	-	1/4	-	067N5153
TGE 10	6	12	3.5	1/2 x 7/8	-	1/4	-	067N5154
TGE 10	6	12	3.5	-	16 x 22	-	6	067N5195
TGE 10	8	17	4.5	5/8 x 7/8	-	1/4	-	067N5156
TGE 10	8	17	4.5	-	16 x 22	-	6	067N5196
TGE 10	9	20	5.5	5/8 x 7/8	-	1/4	-	067N5260
TGE 10	11	24	7	5/8 x 7/8	-	1/4	-	067N5157
TGE 10	12.5	29	8	5/8 x 7/8	-	1/4	-	067N5720
TGE 10	16	35	9.5	7/8 x 1 1/8	-	1/4	-	067N5721
TGE 20	12.5	29	8	5/8 x 7/8	-	1/4	-	067N5159
TGE 20	16	37	10	5/8 x 1 1/8	-	1/4	-	067N5161
TGE 20	16	37	10	7/8 x 1 1/8	-	1/4	-	067N5162
TGE 20	20	44	12	7/8 x 1 1/8	-	1/4	-	067N5163
TGE 40	26	61	17	7/8 x 1 3/8	-	1/4	-	067N5165
TGE 40	26	61	17	1 1/8 x 1 3/8	-	1/4	-	067N5166
TGE 40	30	70	20	7/8 x 1 3/8	-	1/4	-	067N5167
TGE 40	30	70	20	1 1/8 x 1 3/8	-	1/4	-	067N5168
TGE 40	40	87	25	1 1/8 x 1 3/8	-	1/4	-	067N5169

The rated capacity is based on:
 Evaporating temperature t_e : 4.4 °C / 40 °F
 Condensing temperature t_c : 38 °C / 100 °F
 Refrigerant temperature ahead of valve t_1 : 37 °C / 98 °F

Range N -40 – 10 °C / -40 –50 °F, OS = 4 K / 7.2 °F

R134a

Valve type	Orifice no.	Rated capacity		Connections flare / MIO				Code no. Multi pack
		[KW]	[TR]	Inlet x Outlet [inch]		Pressure equalization [inch]		
				Flare	MIO	Flare	MIO	
TGE 10	3	6	1.5	-	1/2 x 3/8	-	1/4	067N7150
TGE 10	4	8	2.5	-	3/8 x 1/2	1/4	-	067N7153
TGE 10	4	8	2.5	3/8 x 1/2	-	1/4	-	067N7154
TGE 10	6	12	3.5	-	1/2 x 5/8	-	1/4	067N7171
TGE 10	6	12	3.5	1/2 x 5/8	-	1/4	-	067N7157
TGE 10	6	12	3.5	-	3/8 x 1/2	1/4	-	067N7158
TGE 10	6	12	3.5	3/8 x 1/2	-	1/4	-	067N7160
TGE 10	6	12	3.5	-	3/8 x 1/2	-	1/4	067N7177
TGE 10	8	17	4.5	-	3/8 x 1/2	-	1/4	067N7176
TGE 10	8	17	4.5	-	1/2 x 5/8	-	1/4	067N7161
TGE 10	8	17	4.5	1/2 x 5/8	-	1/4	-	067N7163
TGE 10	8	17	4.5	-	3/8 x 1/2	1/4	-	067N7164
TGE 10	8	17	4.5	-	5/8 x 3/4	-	1/4	067N7165
TGE 10	9	20	5.5	-	5/8 x 3/4	-	1/4	067N7181
TGE 10	11	24	7	-	5/8 x 3/4	-	1/4	067N7166
TGE 10	12.5	29	8	-	5/8 x 3/4	-	1/4	067N7200
TGE 10	16	35	9.5	-	5/8 x 3/4	-	1/4	067N7201
TGE 10	16	35	9.5	5/8 x 3/4	-	1/4	-	067N7203
TGE 20	12.5	29	8	-	5/8 x 3/4	-	1/4	067N7167
TGE 20	16	37	10	-	5/8 x 3/4	-	1/4	067N7169
TGE 20	16	37	10	5/8 x 3/4	-	1/4	-	067N7168
TGE 20	20	44	12	-	5/8 x 3/4	-	1/4	067N7174

The rated capacity is based on:
 Evaporating temperature t_e : 4.4 °C / 40 °F
 Condensing temperature t_c : 38 °C / 100 °F
 Refrigerant temperature ahead of valve t_1 : 37 °C / 98 °F

Ordering

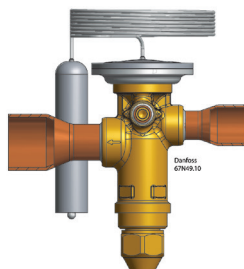

Range K -25 – 10 °C / -15 – 50 °F with MOP 15 °C / 60 °F, OS = 4 K / 7.2 °F

R134a

Valve type	Orifice no.	Rated capacity		Connections solder ODF				Code no. Multi pack
		[KW]	[TR]	Inlet x Outlet		Pressure equalization		
				[inch]	[mm]	[inch]	[mm]	
TGE 10	3	6	1.5	3/8 x 5/8	–	1/4	–	067N5000
TGE 10	4	8	2.5	1/2 x 7/8	–	1/4	–	067N5002
TGE 10	6	12	3.5	1/2 x 5/8	–	1/4	–	067N5003
TGE 10	6	12	3.5	–	12 x 16	–	6	067N5043
TGE 10	6	12	3.5	5/8 x 7/8	–	1/4	–	067N5005
TGE 10	8	17	4.5	5/8 x 7/8	–	1/4	–	067N5006
TGE 10	11	24	7	5/8 x 7/8	–	1/4	–	067N5007
TGE 10	11	24	7	–	16 x 22	–	6	067N5047
TGE 10	11	24	7	5/8 x 1 1/8	–	1/4	–	067N5008
TGE 10	12.5	29	8	5/8 x 7/8	–	1/4	–	067N5700
TGE 20	12.5	29	8	5/8 x 7/8	–	1/4	–	067N5009
TGE 20	16	37	10	5/8 x 1 1/8	–	1/4	–	067N5011
TGE 20	20	44	12	7/8 x 1 1/8	–	1/4	–	067N5013
TGE 40	26	61	17	7/8 x 1 3/8	–	1/4	–	067N5015
TGE 40	30	70	20	1 1/8 x 1 3/8	–	1/4	–	067N5018
TGE 40	40	87	25	1 1/8 x 1 3/8	–	1/4	–	067N5019

The rated capacity is based on:
 Evaporating temperature t_e : 4.4 °C / 40 °F
 Condensing temperature t_c : 38 °C / 100 °F
 Refrigerant temperature ahead of valve t_i : 37 °C / 98 °F

Range K -25 – 10 °C / -15 – 50 °F with MOP 15 °C / 60 °F, OS = 4 K / 7.2 °F

R134a

Valve type	Orifice no.	Rated capacity		Connections flare / MIO				Code no. Multi pack
		[KW]	[TR]	Inlet x Outlet [inch]		Pressure equalization [inch]		
				Flare	MIO	Flare	MIO	
TGE 10	4	8	2.5	–	1/2 x 5/8	–	1/4	067N7002
TGE 10	6	12	3.5	3/8 x 1/2	–	1/4	–	067N7003
TGE 10	6	12	3.5	1/2 x 5/8	–	1/4	–	067N7004
TGE 10	8	17	4.5	–	1/2 x 5/8	–	1/4	067N7010
TGE 10	8	17	4.5	1/2 x 5/8	–	1/4	–	067N7008
TGE 10	8	17	4.5	–	5/8 x 3/4	–	1/4	067N7012
TGE 10	8	17	4.5	5/8 x 3/4	–	1/4	–	067N7013
TGE 10	9	20	5.5	–	5/8 x 3/4	–	1/4	067N7046
TGE 10	11	24	7	–	5/8 x 3/4	–	1/4	067N7015
TGE 10	11	24	7	5/8 x 3/4	–	1/4	–	067N7016
TGE 10	12.5	29	8	–	5/8 x 3/4	–	1/4	067N7210
TGE 10	12.5	29	8	5/8 x 3/4	–	1/4	–	067N7212
TGE 10	16	35	9.5	–	5/8 x 3/4	–	1/4	067N7211
TGE 20	12.5	29	8	–	5/8 x 3/4	–	1/4	067N7017
TGE 20	12.5	29	8	5/8 x 3/4	–	1/4	–	067N7018
TGE 20	16	37	10	–	5/8 x 3/4	–	1/4	067N7019
TGE 20	16	37	10	5/8 x 3/4	–	1/4	–	067N7020
TGE 20	20	44	12	5/8 x 3/4	–	1/4	–	067N7021

The rated capacity is based on:
 Evaporating temperature t_e : 4.4 °C / 40 °F
 Condensing temperature t_c : 38 °C / 100 °F
 Refrigerant temperature ahead of valve t_i : 37 °C / 98 °F

Data sheet | Thermostatic expansion valves, type TGE 10, TGE 20, TGE 40

Ordering

Only solder versions, connection size 28 mm / 1 1/8 in. or below are approved for flammable refrigerants.

Range -30 – 10 °C / -22 – 50 °F, OS = 4 K / 7.2 °F

R1234ze

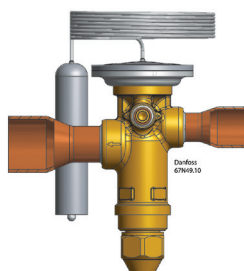

Valve type	Orifice no.	Rated capacity		Connections solder ODF		Code no. Multi pack
		[KW]	[TR]	Inlet x Outlet	Pressure equalization	
				[inch]	[inch]	
TGE 10	8	14	4	3/8 x 3/8	1/4	067N8001
TGE 10	11	20	5.5	3/8 x 3/8	1/4	067N8002
TGE 10	12.5	22	6	3/8 x 3/8	1/4	067N8003
TGE 20	20	31	8.5	7/8 x 1 1/8	1/4	067N8004
TGE 40	26	49	14	7/8 x 1 1/8	1/4	067N8005

The rated capacity is based on:
 Evaporating temperature t_e : 4.4 °C / 40 °F
 Condensing temperature t_c : 38 °C / 100 °F
 Refrigerant temperature ahead of valve t_1 : 37 °C / 98 °F

Range N -40 – 10 °C / -40 – 50 °F, OS = 4 K / 7.2 °F

R407F/R407A¹⁾

Valve type	Orifice no.	Rated capacity R407F		Rated capacity R407A		Connections solder ODF		Code no. Multi pack
		[KW]	[TR]	[KW]	[TR]	Inlet x Outlet	Pressure equalization	
						[inch]	[inch]	
TGE 10	4	14	4	12	3.5	1/2 x 7/8	1/4	067N4700
TGE 10	6	20	6	17	5	5/8 x 7/8	1/4	067N4701
TGE 10	8	27	7.5	23	6.5	5/8 x 7/8	1/4	067N4702
TGE 10	9	32	9	28	8	5/8 x 7/8	1/4	067N4703
TGE 10	11	40	11	34	10	5/8 x 1 1/8	1/4	067N4704

The rated capacity is based on:
 Evaporating temperature t_e : 4.4 °C / 40 °F
 Condensing temperature t_c : 38 °C / 100 °F
 Refrigerant temperature ahead of valve t_1 : 37 °C / 98 °F

¹⁾ On systems charged with R407F, SS = 4.0 °C / 7.2 °F, on systems charged with R407A, SS = 2.7 °C / 4.9 °F.

Range N -40 – 10 °C / -40 – 50 °F, OS = 4 K / 7.2 °F

R404A/R507

Valve type	Orifice no.	Rated capacity		Connections solder ODF		Code no. Multi pack
		[KW]	[TR]	Inlet x Outlet [inch]	Pressure equalization [inch]	
TGE 10	3	7	2	3/8 x 5/8	1/4	067N6170
TGE 10	4	9	2.5	1/2 x 7/8	1/4	067N6172
TGE 10	6	14	4	1/2 x 5/8	1/4	067N6173
TGE 10	6	14	4	1/2 x 7/8	1/4	067N6151
TGE 10	8	18	5	1/2 x 5/8	1/4	067N6175
TGE 10	8	18	5	5/8 x 7/8	1/4	067N6150
TGE 10	9	21	6	5/8 x 7/8	1/4	067N6167
TGE 10	11	26	7.5	5/8 x 7/8	1/4	067N6154
TGE 10	12.5	31	9	5/8 x 7/8	1/4	067N6300
TGE 10	16	35	10	5/8 x 1 1/8	1/4	067N6301
TGE 20	12.5	31	9	5/8 x 7/8	1/4	067N6158
TGE 20	16	39	11	5/8 x 1 1/8	1/4	067N6155
TGE 20	16	39	11	1 1/8 x 1 3/8	1/4	067N6188
TGE 20	16	39	11	7/8 x 1 1/8	1/4	067N6181
TGE 20	20	45	13	7/8 x 1 1/8	1/4	067N6162
TGE 40	26	64	18	7/8 x 1 3/8	1/4	067N6161
TGE 40	30	72	21	1 1/8 x 1 3/8	1/4	067N6186
TGE 40	40	92	26	1 1/8 x 1 3/8	1/4	067N6187

The rated capacity is based on:
 Evaporating temperature t_e : 4.4 °C / 40 °F
 Condensing temperature t_c : 38 °C / 100 °F
 Refrigerant temperature ahead of valve t_1 : 37 °C / 98 °F

Ordering

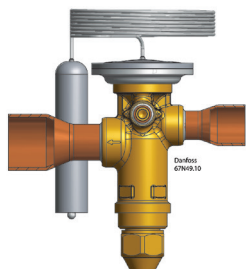

Range N -40 – 10 °C / -40 –50 °F, OS = 4 K / 7.2 °F

R407C

Valve type	Orifice no.	Rated capacity		Connections solder ODF				Code no. Multi pack
		[KW]	[TR]	Inlet x Outlet		Pressure equalization		
				[inch]	[mm]	[inch]	[mm]	
TGE 10	3	9	2.5	½ x ⅝	–	¼	–	067N4151
TGE 10	3	9	2.5	–	12 x 16	–	6	067N4191
TGE 10	4	13	3.5	½ x ⅝	–	¼	–	067N4152
TGE 10	4	13	3.5	–	12 x 22	–	6	067N4192
TGE 10	6	19	5	½ x ⅝	–	¼	–	067N4153
TGE 10	6	19	5	–	12 x 16	–	6	067N4193
TGE 10	8	25	7	½ x ⅝	–	¼	–	067N4236
TGE 10	8	25	7	⅝ x ⅝	–	¼	–	067N4156
TGE 10	8	25	7	–	16 x 22	–	6	067N4196
TGE 10	11	36	10	⅝ x ⅝	–	¼	–	067N4157
TGE 10	11	36	10	–	16 x 22	–	6	067N4197
TGE 10	12.5	39	11	⅝ x ⅝	–	¼	–	067N4410
TGE 10	16	49	14	⅞ x 1 ⅛	–	¼	–	067N4411
TGE 20	12.5	42	12	⅝ x ⅝	–	¼	–	067N4159
TGE 20	16	53	15	⅝ x 1 ⅛	–	¼	–	067N4161
TGE 20	16	53	15	⅞ x 1 ⅛	–	¼	–	067N4162
TGE 20	20	62	18	⅞ x 1 ⅛	–	¼	–	067N4163
TGE 40	26	84	24	⅞ x 1 ⅜	–	¼	–	067N4165
TGE 40	30	95	27	⅞ x 1 ⅜	–	¼	–	067N4167
TGE 40	40	121	34	1 ⅛ x 1 ⅜	–	¼	–	067N4169

The rated capacity is based on:
 Evaporating temperature t_e : 4.4 °C / 40 °F
 Condensing temperature t_c : 38 °C / 100 °F
 Refrigerant temperature ahead of valve t_1 : 37 °C / 98 °F

Range N -40 – 10 °C / -40 –50 °F, OS = 4 K / 7.2 °F

R407C

Valve type	Orifice no.	Rated capacity		Connections MIO		Code no. Multi pack
		[KW]	[TR]	Inlet x Outlet inch	Pressure equalization inch	
TGE 10	4	13	3.5	½ x ⅝ MIO	¼ MIO	067N7400
TGE 10	6	19	5	½ x ⅝ MIO	¼ MIO	067N7401
TGE 10	8	25	7	⅝ x ¾ MIO	¼ MIO	067N7402
TGE 10	11	36	10	⅝ x ¾ MIO	¼ MIO	067N7403

The rated capacity is based on:
 Evaporating temperature t_e : 4.4 °C / 40 °F
 Condensing temperature t_c : 38 °C / 100 °F
 Refrigerant temperature ahead of valve t_1 : 37 °C / 98 °F



Data sheet | Thermostatic expansion valves, type TGE 10, TGE 20, TGE 40

Ordering

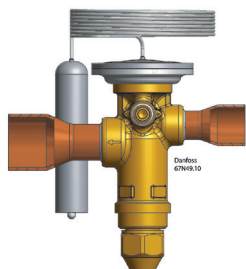

Range K -25 – 10 °C / -15 – 50 °F with MOP 15 °C / 60 °F, OS = 4 K / 7.2 °F

R407C

Valve type	Orifice no.	Rated capacity		Connections solder ODF				Code no. Multi pack
		[KW]	[TR]	Inlet x Outlet		Pressure equalization		
				[inch]	[mm]	[inch]	[mm]	
TGE 10	3	9	2.5	3/8 x 3/8	-	1/4	-	067N4000
TGE 10	3	9	2.5	-	12 x 16	-	6	067N4041
TGE 10	4	13	3.5	1/2 x 7/8	-	1/4	-	067N4002
TGE 10	6	19	5	1/2 x 3/4	-	1/4	-	067N4003
TGE 10	6	19	5	1/2 x 7/8	-	1/4	-	067N4004
TGE 10	8	25	7	5/8 x 7/8	-	1/4	-	067N4006
TGE 10	8	25	7	-	16 x 22	-	6	067N4046
TGE 10	11	36	10	5/8 x 7/8	-	1/4	-	067N4007
TGE 10	11	36	10	-	16 x 22	-	6	067N4047
TGE 10	12.5	39	11	3/8 x 1 1/8	-	1/4	-	067N4400
TGE 10	16	49	14	3/8 x 1 1/8	-	1/4	-	067N4401
TGE 20	12.5	42	12	5/8 x 7/8	-	1/4	-	067N4009
TGE 20	12.5	42	12	3/8 x 1 1/8	-	1/4	-	067N4010
TGE 20	16	53	15	3/8 x 1 1/8	-	1/4	-	067N4011
TGE 20	20	62	18	7/8 x 1 1/8	-	1/4	-	067N4013
TGE 40	26	84	24	7/8 x 1 3/8	-	1/4	-	067N4015
TGE 40	30	95	27	7/8 x 1 3/8	-	1/4	-	067N4017
TGE 40	40	121	34	1 1/8 x 1 3/8	-	1/4	-	067N4019

The rated capacity is based on:
 Evaporating temperature t_e : 4.4 °C / 40 °F
 Condensing temperature t_c : 38 °C / 100 °F
 Refrigerant temperature ahead of valve t_1 : 37 °C / 98 °F

Only solder versions, connection size 28mm / 1 1/8 in. or below are approved for flammable refrigerants.

Range N -40 – 10 °C / -40 – 50 °F, OS = 4 K / 7.2 °F

R290¹⁾

Valve type	Orifice no.	Rated capacity		Connections solder ODF		Code no. Multi pack
		[KW]	[TR]	Inlet x Outlet		
				[inch]	[inch]	
TGE 10	6	19	5	5/8 x 7/8	1/4	067N9100
TGE 10	11	36	10	5/8 x 7/8	1/4	067N9103
TGE 20	12.5	44	12	5/8 x 7/8	1/4	067N9104
TGE 20	16	54	15	7/8 x 7/8	1/4	067N9105
TGE 20	20	63	18	7/8 x 7/8	1/4	067N9106

Range K -25 – 10 °C / -15 – 50 °F without MOP, OS = 4 K / 7.2 °F

R290¹⁾

Valve type	Orifice no.	Rated capacity		Connections solder ODF		Code no. Multi pack
		[KW]	[TR]	Inlet x Outlet		
				[inch]	[inch]	
TGE 40	26	92	26	7/8 x 7/8	1/4	067N9107
TGE 40	40	133	38	7/8 x 7/8	1/4	067N9109

The rated capacity is based on:
 Evaporating temperature t_e : 4.4 °C / 40 °F
 Condensing temperature t_c : 38 °C / 100 °F
 Refrigerant temperature ahead of valve t_1 : 37 °C / 98 °F
¹⁾ SS = 5K / 9°F (except 067N9100, 067N9103)

Ordering (Spare parts)

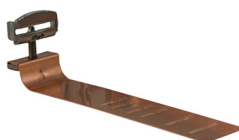

Bulb straps (delivered separately) in Industrial pack

Code no.	Max. tube diameter	Quantity / pack
067N0551	7/8	40
067N0557	2 1/8	40
067N0559	3 1/8	40



Data sheet | Thermostatic expansion valves, type TGE 10, TGE 20, TGE 40

Sizing

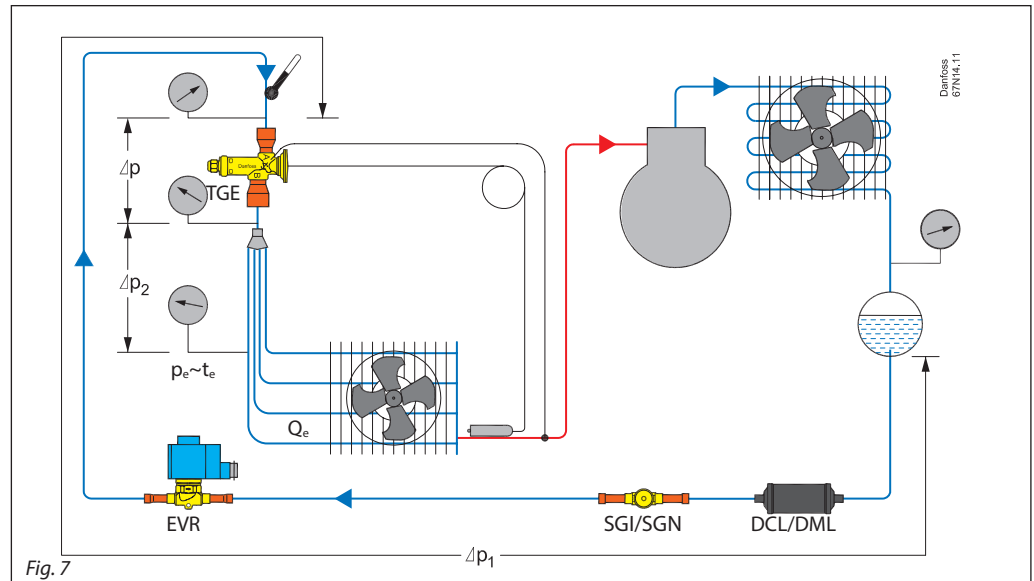

Fig. 7

Sizing examples (SI units)

Refrigerant: R410A
 Evaporator capacity : $Q_e = 30 \text{ kW}$
 Evaporator with several circuits, i.e. a valve with distributor is required
 Evaporating temperature: $t_e = 0 \text{ }^\circ\text{C}$
 Condensing temperature: $p_c = 7 \text{ bar}$
 $t_c = 35 \text{ }^\circ\text{C}$
 $p_e = 21 \text{ bar}$
 Refrigerant liquid temperature: $t_l = 25 \text{ }^\circ\text{C}$
 Subcooling: $\Delta t_{sub} = 35 \text{ }^\circ\text{C} - 25 \text{ }^\circ\text{C} = 10 \text{ K}$

Pressure drop Δp_2 in the liquid distributor can also be assumed as 1.0 bar.

The correction factor at $\Delta t_{sub} (f_{sub}) = 10 \text{ K}$ is 1.07.

The correction factor at distributor (f_p) = 0.96.

The corrected evaporator capacity thus 30 kW divided by 1.07 and 0.96 = 29.2 kW.

Since the capacity of the expansion valve must be equal to or slightly higher than the corrected evaporator capacity of 29.2 kW, a TGE 10 orifice 08 giving 32 kW would be a suitable choice (See tables below).

Sizing examples (US units)

Refrigerant: R410A
 Evaporator capacity : $Q_e = 8.6 \text{ TR}$
 Evaporator with several circuits, i.e. a valve with distributor is required
 Evaporating temperature: $t_e = 40 \text{ }^\circ\text{F}$
 Condensing temperature: $p_c = 118 \text{ psig}$
 $t_c = 95 \text{ }^\circ\text{F}$
 $p_e = 296 \text{ psig}$
 Refrigerant liquid temperature: $t_l = 75 \text{ }^\circ\text{F}$
 Subcooling: $\Delta t_{sub} = 95 \text{ }^\circ\text{F} - 75 \text{ }^\circ\text{F} = 20 \text{ }^\circ\text{F}$

Pressure drop Δp_2 in the liquid distributor can also be assumed as 15 psi.

The correction factor at $\Delta t_{sub} (f_{sub}) = 20 \text{ }^\circ\text{F}$ is 1.08.

The correction factor at distributor (f_p) = 0.95.

The corrected evaporator capacity thus 8.6 TR divided by 1.08 and 0.95 = 8.38 TR.

Since the capacity of the expansion valve must be equal to or slightly higher than the corrected evaporator capacity of 8.38 TR, a TGE 10 orifice 08 giving 9.4 TR would be a suitable choice (See tables below).

Capacity in kW. -40 – 15 °C
 Opening superheat sh = 4 K

SI units R410A

Valve type	Orifice no.	Cond. temp. [°C]	Evaporating temperature [°C]						
			-40	-30	-20	-10	0	10	15
TGE 10	3	35	5.47	7.09	8.84	10.6	12.1	12.8	12.7
	4	35	7.33	9.52	11.9	14.4	16.4	17.4	17.2
	6	35	10.7	13.9	17.4	21.0	24.1	25.5	25.2
	8	35	14.4	18.7	23.4	28.1	32.0	33.6	33.0
	9	35	16.5	21.5	27.2	32.8	37.2	39.3	39.0

Capacity in TR. -40 – 60 °F
 Opening superheat sh = 7.2 °F

US units R410A

Valve type	Orifice no.	Cond. temp. [°F]	Evaporating temperature [°F]						
			-40	-20	0	20	40	50	60
TGE 10	3	95	1.55	2.07	2.62	3.17	3.57	3.64	3.58
	4	95	2.08	2.78	3.54	4.29	4.84	4.95	4.87
	6	95	3.03	4.06	5.18	6.28	7.09	7.24	7.12
	8	95	4.08	5.45	6.93	8.38	9.40	9.55	9.33
	9	95	4.70	6.29	8.08	9.78	11.0	11.2	11.1

Subcooling correction factor 'fsub'

Subcooling [K]	2	4	10	15	20	25	30
Correction factor	0.98	1.00	1.07	1.13	1.18	1.24	1.30

Subcooling correction factor 'fsub'

Subcooling [°F]	2	7	10	20	30	40	50
Correction factor	0.97	1.00	1.02	1.08	1.15	1.21	1.27

Distributor correction factor 'fp'*

Pressure drop [bar]	Evaporating temperature [°C]						
	-40	-30	-20	-10	0	10	15
Δp	Correction factor						
0	1	1	1	1	1	1	1
1	0.97	0.97	0.97	0.96	0.96	0.94	0.93
1.5	0.96	0.96	0.95	0.95	0.93	0.91	0.89
2	0.94	0.94	0.93	0.93	0.91	0.88	0.85

*Calculated at 32 °C condensing temperature.

Distributor correction factor 'fp'*

Pressure drop [psi]	Evaporating temperature [°F]						
	-40	-20	0	20	40	50	60
Δp	Correction factor						
0	1	1	1	1	1	1	1
15	0.97	0.97	0.97	0.96	0.95	0.94	0.93
25	0.95	0.95	0.94	0.93	0.92	0.90	0.87
30	0.94	0.94	0.93	0.92	0.90	0.88	0.84

*Calculated at 90 °F condensing temperature.



Data sheet | Thermostatic expansion valves, type TGE 10, TGE 20, TGE 40

Capacity in kW. -40 – 15 °C
Opening superheat sh = 4 K

SI units R410A

Valve type	Orifice no.	Cond. temp. [°C]	Evaporating temperature [°C]						
			-40	-30	-20	-10	0	10	15
TGE 10	3	25	5.63	7.19	8.80	10.2	11.1	10.7	9.68
	4	25	7.60	9.73	12.0	14.0	15.2	14.6	13.2
	6	25	11.2	14.4	17.7	20.6	22.4	21.6	19.5
	8	25	15.2	19.5	23.8	27.7	29.9	28.6	25.7
	9	25	17.4	22.3	27.6	32.4	35.3	34.1	30.7
	11	25	22.6	29.1	35.4	40.3	42.1	38.4	33.8
	12.5	25	23.2	30.0	37.2	43.8	47.7	46.3	41.7
TGE 20	12.5	25	22.7	30.1	38.3	46.4	52.1	51.6	47.3
	16	25	28.3	37.7	48.1	58.5	66.2	66.0	60.7
	20	25	34.8	45.9	57.8	69.3	77.0	75.1	67.9
	21	25	45.7	59.0	72.0	81.9	85.2	78.2	68.4
TGE 40	26	25	45.1	59.7	76.7	94.5	108.7	110	101
	30	25	51.3	68.0	87.3	108	123	124	114
	40	25	61.9	82.1	106	132	152	154	140
	42	25	90.8	115	140	161	170	158	139

Capacity in TR. -40 – 60 °F
Opening superheat sh = 7.2 °F

US units R410A

Valve type	Orifice no.	Cond. temp. [°F]	Evaporating temperature [°F]						
			-40	-20	0	20	40	50	60
TGE 10	3	75	1.60	2.09	2.59	2.99	3.10	2.95	2.57
	4	75	2.16	2.83	3.52	4.07	4.24	4.03	3.52
	6	75	3.19	4.19	5.20	6.03	6.26	5.95	5.17
	8	75	4.33	5.67	7.02	8.09	8.33	7.88	6.81
	9	75	4.96	6.51	8.16	9.50	9.89	9.41	8.10
	11	75	6.44	8.48	10.4	11.6	11.5	10.6	8.93
	12.5	75	6.62	8.76	11.0	12.9	13.4	12.8	11.0
TGE 20	12.5	75	6.47	8.83	11.4	13.8	14.8	14.3	12.6
	16	75	8.08	11.1	14.4	17.4	18.9	18.3	16.2
	20	75	9.94	13.5	17.2	20.5	21.7	20.7	18.1
	21	75	13.0	17.2	21.1	23.6	23.3	21.5	17.9
TGE 40	26	75	12.9	17.6	23.0	28.3	31.2	30.4	26.9
	30	75	14.7	20.0	26.2	32.2	35.4	34.4	30.4
	40	75	17.7	24.1	31.9	39.6	43.7	42.5	37.0
	42	75	25.7	33.4	41.0	46.5	46.8	43.5	36.3

Capacity in kW. -40 – 15 °C
Opening superheat sh = 4 K

SI units R410A

Valve type	Orifice no.	Cond. temp. [°C]	Evaporating temperature [°C]						
			-40	-30	-20	-10	0	10	15
TGE 10	3	35	5.47	7.09	8.84	10.6	12.1	12.8	12.7
	4	35	7.33	9.52	11.9	14.4	16.4	17.4	17.2
	6	35	10.7	13.9	17.4	21.0	24.1	25.5	25.2
	8	35	14.4	18.7	23.4	28.1	32.0	33.6	33.0
	9	35	16.5	21.5	27.2	32.8	37.2	39.3	39.0
	11	35	21.4	28.2	35.3	41.8	46.1	46.4	44.4
	12.5	35	21.9	28.7	36.3	43.9	50.0	53.1	52.8
TGE 20	12.5	35	25.7	33.5	42.3	51.0	58.2	62.0	61.7
	16	35	21.3	28.5	36.8	45.9	54.3	59.4	59.5
	20	35	26.4	35.3	45.8	57.4	68.4	75.4	75.7
	21	35	32.4	43.1	55.2	68.3	80.4	87.2	86.6
TGE 40	26	35	44.8	58.7	73.0	85.2	92.6	92.9	89.9
	26	35	41.5	55.4	72.1	91.3	111	124	126
	30	35	47.0	62.8	81.8	104	125	140	142
	40	35	57.4	77.2	102	130	157	175	177
	42	35	90.3	116	143	169	186	189	184

Capacity in TR. -40 – 60 °F
Opening superheat sh = 7.2 °F

US units R410A

Valve type	Orifice no.	Cond. temp. [°F]	Evaporating temperature [°F]						
			-40	-20	0	20	40	50	60
TGE 10	3	95	1.55	2.07	2.62	3.17	3.57	3.64	3.58
	4	95	2.08	2.78	3.54	4.29	4.84	4.95	4.87
	6	95	3.03	4.06	5.18	6.28	7.09	7.24	7.12
	8	95	4.08	5.45	6.93	8.38	9.40	9.55	9.33
	9	95	4.70	6.29	8.08	9.78	11.0	11.2	11.1
	11	95	6.07	8.23	10.5	12.4	13.3	13.2	12.5
	12.5	95	6.20	8.37	10.8	13.1	14.7	15.1	15.0
TGE 20	12.5	95	7.29	9.79	12.6	15.2	17.2	17.6	17.5
	16	95	6.06	8.34	11.0	13.9	16.3	16.9	16.9
	20	95	7.48	10.3	13.7	17.4	20.5	21.4	21.5
	21	95	9.19	12.6	16.5	20.6	24.0	24.8	24.5
TGE 40	26	95	12.7	17.1	21.6	25.1	26.6	26.4	25.4
	26	95	11.8	16.2	21.6	27.8	33.4	35.2	35.7
	30	95	13.3	18.4	24.5	31.5	37.9	39.9	40.3
	40	95	16.3	22.6	30.7	39.7	47.3	49.6	50.1
	42	95	25.7	33.7	42.4	49.8	53.8	53.8	51.8

Subcooling correction factor 'fsub'

Subcooling [K]	2	4	10	15	20	25	30
Correction factor	0.98	1.00	1.07	1.13	1.18	1.24	1.30

Subcooling correction factor 'fsub'

Subcooling [°F]	2	7	10	20	30	40	50
Correction factor	0.97	1.00	1.02	1.08	1.15	1.21	1.27

Distributer correction factor 'fp' *

Pressure drop [bar] Δp	Evaporating temperature [°C]						
	-40	-30	-20	-10	0	10	15
	Correction factor						
0	1	1	1	1	1	1	1
1	0.97	0.97	0.97	0.96	0.96	0.94	0.93
1.5	0.96	0.96	0.95	0.95	0.93	0.91	0.89
2	0.94	0.94	0.93	0.93	0.91	0.88	0.85

*Calculated at 32 °C condensing temperature.

Distributer correction factor 'fp' *

Pressure drop [psi] Δp	Evaporating temperature [°F]						
	-40	-20	0	20	40	50	60
	Correction factor						
0	1	1	1	1	1	1	1
15	0.97	0.97	0.97	0.96	0.95	0.94	0.93
25	0.95	0.95	0.94	0.93	0.92	0.90	0.87
30	0.94	0.94	0.93	0.92	0.90	0.88	0.84

*Calculated at 90 °F condensing temperature.



Data sheet | Thermostatic expansion valves, type TGE 10, TGE 20, TGE 40

Capacity in kW. -40 – 15 °C
Opening superheat sh = 4 K

SI units R410A

Valve type	Orifice no.	Cond. temp. [°C]	Evaporating temperature [°C]						
			-40	-30	-20	-10	0	10	15
TGE 10	3	45	5.14	6.72	8.47	10.3	12.2	13.6	13.9
	4	45	6.83	8.95	11.3	13.9	16.4	18.3	18.8
	6	45	9.83	12.9	16.4	20.1	23.8	26.6	27.3
	8	45	13.1	17.2	21.8	26.7	31.5	35.0	35.7
	9	45	15.1	19.9	25.5	31.4	36.7	40.5	41.6
	11	45	19.4	26.1	33.4	40.7	46.7	49.7	49.4
	12.5	45	19.6	26.2	33.7	41.6	48.8	54.2	56.0
TGE 20	12.5	45	19.4	25.9	33.7	42.6	51.9	60.0	62.6
	16	45	23.8	31.9	41.6	52.8	64.8	75.3	78.9
	20	45	29.1	38.9	50.3	63.1	76.7	88.5	92.2
	21	45	42.4	56.3	71.1	84.7	94.3	98.7	98.8
TGE 40	26	45	37.0	49.5	64.7	82.9	103	122	129
	30	45	41.7	55.9	73.2	93.8	117	138	145
	40	45	50.9	69.2	92.9	121	151	176	185
	42	45	87.1	113	141	169	191	202	203

Capacity in TR. -40 – 60 °F
Opening superheat sh = 7.2 °F

US units R410A

Valve type	Orifice no.	Cond. temp. [°F]	Evaporating temperature [°F]						
			-40	-20	0	20	40	50	60
TGE 10	3	115	1.45	1.94	2.50	3.10	3.64	3.85	3.97
	4	115	1.92	2.59	3.35	4.16	4.91	5.20	5.37
	6	115	2.76	3.73	4.84	6.02	7.12	7.54	7.78
	8	115	3.66	4.97	6.43	7.98	9.39	9.90	10.2
	9	115	4.22	5.75	7.54	9.38	10.9	11.5	11.9
	11	115	5.43	7.56	9.87	12.1	13.8	14.1	14.1
	12.5	115	5.49	7.55	9.96	12.4	14.6	15.4	16.0
TGE 20	12.5	115	5.44	7.49	9.97	12.8	15.7	16.9	17.8
	16	115	6.65	9.21	12.3	15.9	19.6	21.2	22.4
	20	115	8.15	11.2	14.9	19.0	23.2	25.0	26.2
	21	115	11.9	16.3	21.0	25.0	27.5	28.1	28.2
TGE 40	26	115	10.3	14.3	19.2	25.1	31.4	34.3	36.6
	30	115	11.7	16.1	21.7	28.3	35.5	38.7	41.3
	40	115	14.2	20.0	27.7	36.8	46.0	49.8	52.8
	42	115	24.6	32.7	41.7	50.2	56.1	57.6	57.9

Capacity in kW. -40 – 15 °C
Opening superheat sh = 4 K

SI units R410A

Valve type	Orifice no.	Cond. temp. [°C]	Evaporating temperature [°C]						
			-40	-30	-20	-10	0	10	15
TGE 10	3	55	4.67	6.13	7.76	9.53	11.4	13.0	13.6
	4	55	6.14	8.09	10.3	12.7	15.2	17.4	18.3
	6	55	8.70	11.5	14.7	18.2	21.8	25.1	26.3
	8	55	11.4	15.2	19.4	24.0	28.7	32.8	34.2
	9	55	13.0	17.4	22.7	28.4	33.9	38.5	40.4
	11	55	16.8	23.1	30.1	37.3	43.9	48.3	49.1
	12.5	55	16.6	22.5	29.5	37.2	44.6	51.0	53.7
TGE 20	12.5	55	17.1	22.8	29.5	37.3	45.9	54.4	58.0
	16	55	20.7	27.7	36.1	45.9	56.8	67.7	72.5
	20	55	25.3	33.9	43.7	55.0	67.5	80.2	85.7
	21	55	38.3	51.7	66.4	80.3	91.1	97.7	99.4
TGE 40	26	55	32.0	42.8	55.9	71.6	89.6	108	117
	30	55	35.9	48.1	63.0	80.8	101	122	132
	40	55	42.4	58.3	79.4	106	135	163	175
	42	55	81.1	106	134	163	187	202	206

Capacity in TR. -40 – 60 °F
Opening superheat sh = 7.2 °F

US units R410A

Valve type	Orifice no.	Cond. temp. [°F]	Evaporating temperature [°F]						
			-40	-20	0	20	40	50	60
TGE 10	3	135	1.29	1.74	2.25	2.81	3.36	3.60	3.80
	4	135	1.69	2.30	2.98	3.73	4.49	4.82	5.09
	6	135	2.39	3.26	4.25	5.34	6.43	6.92	7.30
	8	135	3.13	4.29	5.60	7.02	8.43	9.04	9.50
	9	135	3.53	4.90	6.56	8.35	9.99	10.7	11.3
	11	135	4.59	6.55	8.72	10.9	12.8	13.4	13.7
	12.5	135	4.50	6.32	8.52	10.9	13.1	14.1	15.0
TGE 20	12.5	135	4.70	6.44	8.52	11.0	13.6	14.9	16.1
	16	135	5.68	7.82	10.4	13.5	16.9	18.5	20.0
	20	135	6.93	9.55	12.6	16.1	20.0	21.9	23.7
	21	135	10.6	14.8	19.4	23.5	26.5	27.4	28.0
TGE 40	26	135	8.74	12.1	16.2	21.1	26.7	29.6	32.2
	30	135	9.80	13.6	18.2	23.8	30.2	33.4	36.4
	40	135	11.4	16.3	23.0	31.3	40.3	44.7	48.6
	42	135	22.5	30.4	39.3	48.0	54.8	57.0	58.4

Subcooling correction factor 'fsub'

Subcooling [K]	2	4	10	15	20	25	30
Correction factor	0.98	1.00	1.07	1.13	1.18	1.24	1.30

Subcooling correction factor 'fsub'

Subcooling [°F]	2	7	10	20	30	40	50
Correction factor	0.97	1.00	1.02	1.08	1.15	1.21	1.27

Distributor correction factor 'fp' *

Pressure drop [bar] Δp	Evaporating temperature [°C]						
	-40	-30	-20	-10	0	10	15
	Correction factor						
0	1	1	1	1	1	1	1
1	0.97	0.97	0.97	0.96	0.96	0.94	0.93
1.5	0.96	0.96	0.95	0.95	0.93	0.91	0.89
2	0.94	0.94	0.93	0.93	0.91	0.88	0.85

*Calculated at 32 °C condensing temperature.

Distributor correction factor 'fp' *

Pressure drop [psi] Δp	Evaporating temperature [°F]						
	-40	-20	0	20	40	50	60
	Correction factor						
0	1	1	1	1	1	1	1
15	0.97	0.97	0.97	0.96	0.95	0.94	0.93
25	0.95	0.95	0.94	0.93	0.92	0.90	0.87
30	0.94	0.94	0.93	0.92	0.90	0.88	0.84

*Calculated at 90 °F condensing temperature.



Data sheet | Thermostatic expansion valves, type TGE 10, TGE 20, TGE 40

Capacity in kW. -40 – 15 °C

Opening superheat sh = 4 K

SI units R32

Valve type	Orifice no.	Cond. temp. [°C]	Evaporating temperature [°C]						
			-40	-30	-20	-10	0	10	15
TGE 10	3	25	8.96	11.4	13.9	16.1	17.3	16.5	14.7
	4	25	12.1	15.4	18.8	21.8	23.5	22.4	20.0
	6	25	17.6	22.5	27.7	32.0	34.4	32.8	29.4
	8	25	23.8	30.4	37.1	42.7	45.4	43.0	38.3
	9	25	25.6	33.0	40.9	47.6	51.3	49.2	44.1
	11	25	35.3	45.7	55.5	62.0	62.9	56.6	49.6
	12.5	25	33.9	44.0	54.6	63.9	68.9	66.2	59.5
TGE 20	16	25	39.9	51.4	63.5	74.0	79.9	76.5	68.3
	12.5	25	35.8	47.6	60.4	72.8	81.5	80.0	72.1
	16	25	44.5	59.0	75.3	91.0	102	103	94.4
	20	25	54.6	71.6	90.0	107	118	116	104
TGE 40	21	25	67.9	88.2	106	120	124	113	97.9
	26	25	67.5	89.4	114	140	159	161	147
	30	25	76.6	102	130	158	180	182	167
	40	25	92.6	123	159	197	226	224	198
	42	25	142	180	217	246	256	233	202

Capacity in TR, range: -40 – 60 °F

Opening superheat sh = 7.2 °F

US units R32

Valve type	Orifice no.	Cond. temp. [°F]	Evaporating temperature [°F]						
			-40	-20	0	20	40	50	60
TGE 10	3	75	2.54	3.32	4.07	4.67	4.79	4.52	3.87
	4	75	3.42	4.48	5.52	6.33	6.52	6.16	5.27
	6	75	5.01	6.55	8.12	9.32	9.56	9.04	7.72
	8	75	6.75	8.82	10.9	12.4	12.6	11.9	10.1
	9	75	7.27	9.62	12.0	13.9	14.3	13.6	11.6
	11	75	10.0	13.3	16.2	17.7	17.0	15.6	13.0
	12.5	75	9.66	12.8	16.1	18.7	19.3	18.3	15.7
TGE 20	16	75	11.3	15.0	18.7	21.6	22.3	21.1	17.9
	12.5	75	10.2	13.9	18.0	21.6	23.0	22.0	19.1
	16	75	12.7	17.3	22.4	27.0	29.2	28.4	25.0
	20	75	15.5	20.9	26.7	31.5	33.4	32.0	27.3
TGE 40	21	75	19.3	25.5	31.0	34.4	33.7	30.9	25.6
	26	75	19.2	26.2	34.1	41.6	45.6	44.5	38.9
	30	75	21.8	29.8	38.8	47.2	51.6	50.4	44.1
	40	75	26.4	36.1	47.6	58.8	64.4	61.7	51.6
	42	75	40.1	52.1	63.1	70.6	69.7	64.0	52.9

Capacity in kW. -40 – 15 °C

Opening superheat sh = 4 K

SI units R32

Valve type	Orifice no.	Cond. temp. [°C]	Evaporating temperature [°C]						
			-40	-30	-20	-10	0	10	15
TGE 10	3	35	9.01	11.6	14.4	17.0	19.2	20.1	19.8
	4	35	12.0	15.6	19.3	23.0	25.9	27.3	26.8
	6	35	17.4	22.5	28.1	33.4	37.4	39.0	38.7
	8	35	23.3	30.1	37.5	44.3	49.2	51.0	50.2
	9	35	25.0	32.7	41.2	49.3	55.4	58.1	57.6
	11	35	34.6	45.8	57.2	66.2	70.3	69.0	66.3
	12.5	35	32.7	43.1	54.5	65.5	73.9	77.6	77.0
TGE 20	16	35	38.5	50.4	63.5	76.2	86.1	90.7	89.9
	12.5	35	34.6	46.2	59.3	73.3	86.2	93.9	93.6
	16	35	43.0	57.5	74.3	91.6	107	117	119
	20	35	52.6	69.8	89.2	108	125	134	135
TGE 40	21	35	68.7	90.3	111	129	139	139	133
	26	35	64.2	86.0	112	139	164	181	184
	30	35	72.6	97.4	127	157	185	204	208
	40	35	87.6	118	155	198	238	262	262
	42	35	147	188	229	266	290	290	277

Capacity in TR, range: -40 – 60 °F

Opening superheat sh = 7.2 °F

US units R32

Valve type	Orifice no.	Cond. temp. [°F]	Evaporating temperature [°F]						
			-40	-20	0	20	40	50	60
TGE 10	3	95	2.56	3.39	4.25	5.07	5.63	5.72	5.60
	4	95	3.41	4.53	5.71	6.83	7.61	7.74	7.59
	6	95	4.94	6.57	8.34	9.91	10.9	11.1	11.0
	8	95	6.60	8.78	11.1	13.1	14.3	14.5	14.2
	9	95	7.10	9.55	12.2	14.7	16.2	16.5	16.3
	11	95	9.84	13.4	16.9	19.4	20.0	19.6	18.7
	12.5	95	9.29	12.6	16.2	19.5	21.7	22.0	21.8
TGE 20	16	95	11.0	14.7	18.9	22.7	25.3	25.8	25.5
	12.5	95	9.83	13.5	17.7	22.1	25.7	26.7	26.5
	16	95	12.2	16.8	22.2	27.5	31.8	33.1	33.7
	20	95	14.9	20.4	26.6	32.5	36.9	38.1	38.3
TGE 40	21	95	19.5	26.3	32.7	37.7	40.0	39.5	37.5
	26	95	18.2	25.2	33.4	41.9	49.0	51.3	52.3
	30	95	20.6	28.5	37.9	47.5	55.4	58.0	59.0
	40	95	24.9	34.6	46.7	60.2	71.6	74.5	74.1
	42	95	41.6	54.7	67.6	78.3	83.5	82.5	78.0

Subcooling correction factor 'fsub'

Subcooling [K]	2	4	10	15	20	25	30
Correction factor	0.98	1.00	1.06	1.10	1.15	1.20	1.24

Subcooling correction factor 'fsub'

Subcooling [°F]	2	7	10	20	30	40	50
Correction factor	0.97	1.00	1.02	1.07	1.12	1.17	1.22

Distributor correction factor 'fp' *

Pressure drop [bar] Δp	Evaporating temperature [°C]						
	-40	-30	-20	-10	0	10	15
0	1	1	1	1	1	1	1
1	0.97	0.97	0.97	0.96	0.96	0.94	0.93
1.5	0.96	0.96	0.95	0.95	0.94	0.92	0.89
2	0.94	0.94	0.94	0.93	0.91	0.88	0.86

*Calculated at 32 °C condensing temperature.

Distributor correction factor 'fp' *

Pressure drop [psi] Δp	Evaporating temperature [°F]						
	-40	-20	0	20	40	50	60
0	1	1	1	1	1	1	1
15	0.97	0.97	0.97	0.96	0.95	0.94	0.93
25	0.95	0.95	0.94	0.94	0.92	0.90	0.88
30	0.94	0.94	0.93	0.92	0.90	0.88	0.85

*Calculated at 90 °F condensing temperature.



Data sheet | Thermostatic expansion valves, type TGE 10, TGE 20, TGE 40

Capacity in kW. -40 – 15 °C
Opening superheat sh = 4 K

SI units R32

Valve type	Orifice no.	Cond. temp. [°C]	Evaporating temperature [°C]						
			-40	-30	-20	-10	0	10	15
TGE 10	3	45	8.85	11.5	14.3	17.2	19.9	21.9	22.3
	4	45	11.7	15.2	19.1	23.0	26.7	29.4	30.1
	6	45	16.7	21.8	27.6	33.3	38.2	41.7	42.7
	8	45	22.0	28.9	36.5	44.0	50.2	54.2	55.4
	9	45	23.6	31.3	40.0	48.8	56.4	61.7	63.3
	11	45	32.8	44.4	56.9	67.6	74.2	76.1	75.6
	12.5	45	30.4	40.6	52.3	64.1	74.4	81.6	83.9
TGE 20	16	45	35.8	47.6	61.1	74.9	87.2	96.3	99.2
	12.5	45	32.8	43.7	56.3	70.2	84.5	96.7	101
	16	45	40.2	54.2	70.7	88.2	105	119	125
	20	45	49.0	65.8	85.0	105	124	139	145
TGE 40	21	45	67.8	90.0	112	131	146	153	152
	26	45	59.2	79.9	105	132	159	182	192
	30	45	66.6	90.1	118	149	179	205	216
	40	45	80.0	109	146	189	235	273	285
	42	45	148	191	235	276	308	321	318

Capacity in TR, range: -40 – 60 °F
Opening superheat sh = 7.2 °F

US units R32

Valve type	Orifice no.	Cond. temp. [°F]	Evaporating temperature [°F]						
			-40	-20	0	20	40	50	60
TGE 10	3	115	2.51	3.34	4.25	5.16	5.95	6.23	6.40
	4	115	3.30	4.43	5.65	6.90	7.98	8.38	8.61
	6	115	4.70	6.34	8.17	9.95	11.4	11.9	12.2
	8	115	6.21	8.38	10.8	13.1	14.9	15.4	15.8
	9	115	6.66	9.09	11.9	14.6	16.8	17.6	18.1
	11	115	9.23	12.9	16.9	20.0	21.6	21.7	21.6
	12.5	115	8.55	11.8	15.5	19.2	22.1	23.2	24.0
TGE 20	16	115	10.1	13.8	18.1	22.4	26.0	27.4	28.4
	12.5	115	9.23	12.7	16.7	21.2	25.6	27.4	28.7
	16	115	11.3	15.7	21.0	26.5	31.5	33.6	35.6
	20	115	13.8	19.1	25.2	31.5	37.0	39.4	41.5
TGE 40	21	115	19.2	26.2	33.0	38.9	42.8	43.6	43.3
	26	115	16.6	23.2	31.1	39.7	47.8	51.4	54.6
	30	115	18.7	26.1	35.2	44.9	54.0	58.0	61.6
	40	115	22.4	31.7	43.6	57.7	71.8	77.6	81.4
	42	115	42.2	55.6	69.4	81.9	90.3	91.9	90.8

Capacity in kW. -40 – 15 °C
Opening superheat sh = 4 K

SI units R32

Valve type	Orifice no.	Cond. temp. [°C]	Evaporating temperature [°C]						
			-40	-30	-20	-10	0	10	15
TGE 10	3	55	8.53	11.1	13.9	16.9	19.7	22.1	23.0
	4	55	11.1	14.6	18.4	22.3	26.2	29.5	30.7
	6	55	15.5	20.4	26.1	32.0	37.4	41.7	43.6
	8	55	20.1	26.7	34.3	41.9	48.7	54.1	56.2
	9	55	21.5	28.9	37.4	46.4	54.6	61.3	64.1
	11	55	29.7	41.1	54.2	66.2	74.6	78.9	79.9
	12.5	55	27.1	36.7	48.0	60.0	71.0	80.1	84.0
TGE 20	16	55	31.8	43.1	56.2	70.2	83.6	95.3	100
	12.5	55	30.5	40.5	52.1	65.0	78.8	91.9	97.4
	16	55	36.2	49.2	64.7	81.5	97.9	113	120
	20	55	44.0	59.7	78.0	97.4	116	134	142
TGE 40	21	55	65.8	87.8	110	130	146	157	158
	26	55	52.3	71.3	94.2	120	146	170	182
	30	55	58.6	80.0	106	135	164	192	205
	40	55	69.8	96.3	130	172	218	262	280
	42	55	148	190	234	277	312	332	333

Capacity in TR, range: -40 – 60 °F
Opening superheat sh = 7.2 °F

US units R32

Valve type	Orifice no.	Cond. temp. [°F]	Evaporating temperature [°F]						
			-40	-20	0	20	40	50	60
TGE 10	3	135	2.40	3.21	4.10	5.01	5.87	6.23	6.52
	4	135	3.12	4.20	5.39	6.63	7.80	8.30	8.69
	6	135	4.29	5.85	7.66	9.49	11.1	11.8	12.4
	8	135	5.56	7.63	10.0	12.4	14.4	15.2	15.9
	9	135	5.95	8.25	11.0	13.7	16.2	17.2	18.2
	11	135	8.18	11.8	15.9	19.6	21.8	22.4	22.8
	12.5	135	7.45	10.5	14.0	17.7	21.1	22.5	23.8
TGE 20	16	135	8.74	12.3	16.4	20.8	24.9	26.7	28.4
	12.5	135	8.50	11.6	15.3	19.3	23.6	25.6	27.4
	16	135	9.98	14.0	18.9	24.2	29.1	31.5	33.9
	20	135	12.1	17.0	22.8	28.8	34.5	37.3	40.0
TGE 40	21	135	18.5	25.4	32.2	38.4	43.0	44.4	44.9
	26	135	14.4	20.3	27.5	35.4	43.3	47.1	50.9
	30	135	16.0	22.7	30.9	39.9	48.8	53.0	57.3
	40	135	19.1	27.3	38.2	51.6	66.1	72.9	78.6
	42	135	41.8	55.3	69.1	82.0	91.6	94.2	94.7

Subcooling correction factor 'fsub'

Subcooling [K]	2	4	10	15	20	25	30
Correction factor	0.98	1.00	1.06	1.10	1.15	1.20	1.24

Subcooling correction factor 'fsub'

Subcooling [°F]	2	7	10	20	30	40	50
Correction factor	0.97	1.00	1.02	1.07	1.12	1.17	1.22

Distributer correction factor 'fp' *

Pressure drop [bar] Δp	Evaporating temperature [°C]						
	-40	-30	-20	-10	0	10	15
0	1	1	1	1	1	1	1
1	0.97	0.97	0.97	0.96	0.96	0.94	0.93
1.5	0.96	0.96	0.95	0.95	0.94	0.92	0.89
2	0.94	0.94	0.94	0.93	0.91	0.88	0.86

*Calculated at 32 °C condensing temperature.

Distributer correction factor 'fp' *

Pressure drop [psi] Δp	Evaporating temperature [°F]						
	-40	-20	0	20	40	50	60
0	1	1	1	1	1	1	1
15	0.97	0.97	0.97	0.96	0.95	0.94	0.93
25	0.95	0.95	0.94	0.94	0.92	0.90	0.88
30	0.94	0.94	0.93	0.92	0.90	0.88	0.85

*Calculated at 90 °F condensing temperature.



Data sheet | Thermostatic expansion valves, type TGE 10, TGE 20, TGE 40

Capacity in kW. -40 – 15 °C
Opening superheat sh = 4 K

SI units R452B

Valve type	Orifice no.	Cond. temp. [°C]	Evaporating temperature [°C]						
			-40	-30	-20	-10	0	10	15
TGE 10	3	25	5.49	6.90	8.40	9.86	10.9	11.24	10.8
	4	25	7.44	9.36	11.4	13.4	15.0	15.39	14.7
	6	25	11.0	13.9	17.0	20.0	22.3	22.89	21.9
	8	25	14.9	18.9	23.1	27.1	30.2	30.73	29.3
	9	25	17.4	22.1	27.1	31.9	35.7	36.55	34.9
	11	25	21.9	28.1	34.6	40.3	43.7	42.75	39.8
	12.5	25	23.5	29.6	36.4	43.1	48.2	49.1	46.7
TGE 20	12.5	25	21.7	28.5	36.3	44.5	51.8	54.9	53.0
	16	25	27.1	35.6	45.5	56.1	65.7	69.9	67.8
	20	25	33.2	43.5	55.2	67.3	77.7	81.3	77.9
	21	25	44.3	57.6	71.0	82.9	90.2	88.6	82.3
TGE 40	26	25	44.6	60.1	78.0	97.6	116	125	123
	30	25	50.6	68.2	88.7	111	131	142	139
	40	25	60.5	81.6	107	137	164	176	170
	42	25	91.5	118	146	172	187	186	175

Capacity in TR. -40 – 60 °F
Opening superheat sh = 7.2 °F

US units R452B

Valve type	Orifice no.	Cond. temp. [°F]	Evaporating temperature [°F]						
			-40	-20	0	20	40	50	60
TGE 10	3	75	1.56	2.00	2.47	2.90	3.14	3.12	2.91
	4	75	2.11	2.72	3.36	3.95	4.30	4.27	3.99
	6	75	3.13	4.04	5.01	5.89	6.40	6.35	5.93
	8	75	4.26	5.51	6.82	7.99	8.63	8.53	7.93
	9	75	4.96	6.43	7.99	9.42	10.2	10.2	9.46
	11	75	6.24	8.18	10.2	11.8	12.3	11.8	10.7
	12.5	75	6.69	8.63	10.8	12.7	13.8	13.6	12.7
TGE 20	12.5	75	6.18	8.33	10.8	13.3	15.1	15.3	14.4
	16	75	7.71	10.4	13.6	16.9	19.3	19.5	18.5
	20	75	9.47	12.8	16.4	20.1	22.6	22.6	21.2
	21	75	12.6	16.7	20.9	24.2	25.4	24.5	22.2
TGE 40	26	75	12.8	17.7	23.4	29.5	34.3	35.0	33.5
	30	75	14.5	20.1	26.7	33.6	38.9	39.7	37.9
	40	75	17.3	24.1	32.4	41.5	48.4	48.9	45.7
	42	75	25.9	34.4	42.9	50.0	52.9	51.6	47.2

Capacity in kW. -40 – 15 °C
Opening superheat sh = 4 K

SI units R452B

Valve type	Orifice no.	Cond. temp. [°C]	Evaporating temperature [°C]						
			-40	-30	-20	-10	0	10	15
TGE 10	3	35	5.45	6.91	8.54	10.2	11.8	12.9	13.2
	4	35	7.33	9.32	11.5	13.9	16.0	17.6	18.0
	6	35	10.7	13.7	16.9	20.4	23.6	26.0	26.6
	8	35	14.5	18.5	22.9	27.5	31.8	34.8	35.4
	9	35	16.7	21.5	26.7	32.2	37.4	41.2	42.0
	11	35	21.0	27.5	34.6	41.5	47.1	49.8	49.4
	12.5	35	22.4	28.5	35.7	43.3	50.6	55.6	56.4
TGE 20	12.5	35	26.2	33.4	41.6	50.3	58.7	64.6	65.7
	16	35	21.0	27.7	35.6	44.6	53.9	61.4	63.4
	20	35	25.9	34.3	44.3	55.7	67.7	77.6	80.4
	21	35	31.7	41.9	53.7	66.9	80.3	91.0	93.7
TGE 40	26	35	44.1	58.0	72.7	86.9	98.5	101	103
	26	35	41.7	56.5	74.1	94.2	115	134	141
	30	35	47.1	63.9	83.9	107	131	152	159
	40	35	56.2	76.2	102	132	166	196	204
	42	35	92.8	121	151	180	204	217	217

Capacity in TR. -40 – 60 °F
Opening superheat sh = 7.2 °F

US units R452B

Valve type	Orifice no.	Cond. temp. [°F]	Evaporating temperature [°F]						
			-40	-20	0	20	40	50	60
TGE 10	3	95	1.55	2.01	2.53	3.06	3.52	3.67	3.75
	4	95	2.08	2.71	3.42	4.15	4.78	5.00	5.11
	6	95	3.05	3.99	5.04	6.12	7.06	7.39	7.55
	8	95	4.10	5.38	6.80	8.24	9.46	9.88	10.1
	9	95	4.75	6.25	7.94	9.67	11.2	11.7	12.0
	11	95	5.97	8.02	10.3	12.4	13.8	14.1	14.0
	12.5	95	6.35	8.32	10.6	13.0	15.1	15.8	16.0
TGE 20	12.5	95	7.44	9.73	12.4	15.1	17.6	18.4	18.6
	16	95	5.97	8.11	10.7	13.6	16.4	17.5	18.0
	20	95	7.36	10.0	13.3	17.0	20.6	22.1	22.9
	21	95	9.01	12.2	16.0	20.3	24.4	25.9	26.6
TGE 40	26	95	12.5	16.9	21.6	25.9	28.9	29.5	29.1
	26	95	11.8	16.6	22.3	28.7	35.3	38.2	40.2
	30	95	13.4	18.7	25.2	32.6	40.0	43.2	45.4
	40	95	16.0	22.4	30.6	40.7	51.2	55.6	58.2
	42	95	26.4	35.3	44.8	53.7	60.2	61.8	61.6

Subcooling correction factor 'fsub'

Subcooling [K]	2	4	10	15	20	25	30
Correction factor	0.98	1.00	1.06	1.11	1.16	1.21	1.26

Subcooling correction factor 'fsub'

Subcooling [°F]	2	7	10	20	30	40	50
Correction factor	0.98	1.00	1.02	1.07	1.13	1.18	1.24

Distributer correction factor 'fp' *

Pressure drop [bar] Δp	Evaporating temperature [°C]						
	-40	-30	-20	-10	0	10	15
0	1	1	1	1	1	1	1
1	0.97	0.97	0.97	0.96	0.96	0.94	0.93
1.5	0.95	0.95	0.95	0.94	0.93	0.92	0.90
2	0.94	0.94	0.93	0.92	0.91	0.89	0.86

*Calculated at 32 °C condensing temperature.

Distributer correction factor 'fp' *

Pressure drop [psi] Δp	Evaporating temperature [°F]						
	-40	-20	0	20	40	50	60
0	1	1	1	1	1	1	1
15	0.97	0.97	0.96	0.96	0.95	0.94	0.93
25	0.95	0.94	0.94	0.93	0.92	0.90	0.88
30	0.94	0.93	0.93	0.92	0.90	0.88	0.86

*calculated at 90 °F condensing temperature.



Data sheet | Thermostatic expansion valves, type TGE 10, TGE 20, TGE 40

Capacity in kW. -40 – 15 °C
Opening superheat sh = 4 K

SI units R452B

Valve type	Orifice no.	Cond. temp. [°C]	Evaporating temperature [°C]						
			-40	-30	-20	-10	0	10	15
TGE 10	3	45	5.30	6.76	8.41	10.2	12.0	13.5	14.2
	4	45	7.07	9.05	11.3	13.7	16.1	18.3	19.2
	6	45	10.2	13.1	16.4	20.0	23.6	26.8	28.1
	8	45	13.6	17.6	22.0	26.7	31.4	35.6	37.2
	9	45	15.7	20.3	25.5	31.2	36.8	42.0	44.0
	11	45	19.7	26.1	33.4	40.9	47.6	52.4	53.7
	12.5	45	20.7	26.7	33.6	41.5	49.6	56.9	59.5
TGE 20	12.5	45	19.9	26.3	33.9	42.7	52.5	62.	66.0
	16	45	24.3	32.2	41.7	52.8	65.3	77.6	82.9
	20	45	29.6	39.2	50.4	63.4	77.7	91.6	97.5
	21	45	42.9	56.9	72.0	87.3	101	111	113
TGE 40	26	45	38.2	51.9	68.3	87.3	108	130	139
	30	45	42.9	58.4	77.0	98.6	122	146	157
	40	45	51.2	69.6	93.0	122	156	193	209
	42	45	92.4	121	152	183	211	232	237

Capacity in TR. -40 – 60 °F
Opening superheat sh = 7.2 °F

US units R452B

Valve type	Orifice no.	Cond. temp. [°F]	Evaporating temperature [°F]						
			-40	-20	0	20	40	50	60
TGE 10	3	115	1.50	1.96	2.49	3.05	3.60	3.85	4.05
	4	115	2.00	2.62	3.34	4.11	4.86	5.20	5.49
	6	115	2.88	3.81	4.86	5.99	7.10	7.60	8.02
	8	115	3.84	5.08	6.49	8.00	9.45	10.1	10.6
	9	115	4.42	5.87	7.54	9.34	11.1	11.9	12.6
	11	115	5.56	7.59	9.90	12.3	14.2	14.9	15.3
	12.5	115	5.82	7.70	9.94	12.5	15.0	16.1	17.0
TGE 20	12.5	115	5.61	7.62	10.1	13.0	16.1	17.5	18.8
	16	115	6.84	9.33	12.4	16.0	20.0	21.9	23.6
	20	115	8.32	11.4	15.0	19.2	23.7	25.9	27.8
	21	115	12.1	16.6	21.4	26.2	30.2	31.6	32.3
TGE 40	26	115	10.7	15.1	20.3	26.5	33.2	36.5	39.7
	30	115	12.0	17.0	22.9	29.9	37.5	41.2	44.7
	40	115	14.4	20.2	27.8	37.3	49.0	54.3	59.6
	42	115	26.2	35.3	45.1	54.8	63.0	66.0	67.9

Capacity in kW. -40 – 15 °C
Opening superheat sh = 4 K

SI units R452B

Valve type	Orifice no.	Cond. temp. [°C]	Evaporating temperature [°C]						
			-40	-30	-20	-10	0	10	15
TGE 10	3	55	5.07	6.49	8.10	9.85	11.7	13.4	14.2
	4	55	6.71	8.62	10.8	13.2	15.6	18.0	19.1
	6	55	9.58	12.4	15.5	19.0	22.6	26.0	27.6
	8	55	12.6	16.4	20.6	25.2	29.9	34.4	36.4
	9	55	14.5	18.8	23.8	29.2	34.9	40.4	42.9
	11	55	18.2	24.3	31.4	39.0	46.2	52.0	54.2
	12.5	55	18.7	24.2	30.7	38.2	46.2	54.2	57.7
TGE 20	12.5	55	21.9	28.4	35.9	44.4	53.9	63.4	67.8
	12.5	55	18.5	24.3	31.3	39.5	48.7	58.3	62.9
	16	55	22.3	29.5	38.1	48.4	60.0	72.3	78.2
	20	55	27.0	35.8	46.0	58.0	71.4	85.6	92.4
TGE 40	21	55	40.9	54.5	69.4	84.7	99.3	111	115
	26	55	34.5	47.0	61.8	79.0	98.2	119	129
	30	55	38.5	52.6	69.4	88.9	111	134	145
	40	55	46.0	62.5	83.4	109	141	177	195
	42	55	90.7	119	150	181	210	234	243

Capacity in TR. -40 – 60 °F
Opening superheat sh = 7.2 °F

US units R452B

Valve type	Orifice no.	Cond. temp. [°F]	Evaporating temperature [°F]						
			-40	-20	0	20	40	50	60
TGE 10	3	135	1.42	1.87	2.38	2.94	3.51	3.78	4.03
	4	135	1.88	2.48	3.17	3.92	4.69	5.07	5.41
	6	135	2.67	3.55	4.55	5.65	6.77	7.31	7.82
	8	135	3.52	4.69	6.02	7.47	8.94	9.63	10.3
	9	135	4.02	5.39	6.96	8.68	10.5	11.3	12.1
	11	135	5.06	6.99	9.24	11.6	13.8	14.7	15.4
	12.5	135	5.18	6.89	8.95	11.3	13.9	15.1	16.2
TGE 20	12.5	135	6.06	8.07	10.44	13.2	16.2	17.7	19.1
	12.5	135	5.14	6.96	9.17	11.8	14.7	16.2	17.6
	16	135	6.19	8.43	11.2	14.4	18.2	20.1	21.9
	20	135	7.50	10.2	13.5	17.3	21.5	23.7	25.9
TGE 40	21	135	11.5	15.7	20.4	25.3	29.6	31.3	32.6
	26	135	9.56	13.5	18.1	23.6	29.7	32.9	36.0
	30	135	10.7	15.1	20.4	26.5	33.4	37.0	40.5
	40	135	12.7	17.9	24.5	33.0	43.3	48.9	54.6
	42	135	25.6	34.5	44.2	54.0	62.7	66.3	69.2

Subcooling correction factor 'fsub'

Subcooling [K]	2	4	10	15	20	25	30
Correction factor	0.98	1.00	1.06	1.11	1.16	1.21	1.26

Subcooling correction factor 'fsub'

Subcooling [°F]	2	7	10	20	30	40	50
Correction factor	0.98	1.00	1.02	1.07	1.13	1.18	1.24

Distributer correction factor 'fp' *

Pressure drop [bar] Δp	Evaporating temperature [°C]						
	-40	-30	-20	-10	0	10	15
0	1	1	1	1	1	1	1
1	0.97	0.97	0.97	0.96	0.96	0.94	0.93
1.5	0.95	0.95	0.95	0.94	0.93	0.92	0.90
2	0.94	0.94	0.93	0.92	0.91	0.89	0.86

*Calculated at 32 °C condensing temperature.

Distributer correction factor 'fp' *

Pressure drop [psi] Δp	Evaporating temperature [°F]						
	-40	-20	0	20	40	50	60
0	1	1	1	1	1	1	1
15	0.97	0.97	0.96	0.96	0.95	0.94	0.93
25	0.95	0.94	0.94	0.93	0.92	0.90	0.88
30	0.94	0.93	0.93	0.92	0.90	0.88	0.86

*calculated at 90 °F condensing temperature.



Data sheet | Thermostatic expansion valves, type TGE 10, TGE 20, TGE 40

Capacity in kW. -40 – 15 °C
Opening superheat sh = 4 K

SI units R454B

Valve type	Orifice no.	Cond. temp. [°C]	Evaporating temperature [°C]						
			-40	-30	-20	-10	0	10	15
TGE 10	3	25	6.54	8.24	10.0	11.7	12.8	12.7	11.7
	4	25	8.84	11.2	13.6	15.9	17.5	17.3	15.9
	6	25	13.1	16.5	20.2	23.6	26.0	25.7	23.6
	8	25	17.7	22.4	27.4	32.0	35.0	34.3	31.4
	9	25	20.6	26.2	32.1	37.6	41.4	40.8	37.5
	11	25	26.1	33.5	40.9	47.1	50.1	47.1	42.2
	12.5	25	27.4	35.0	43.2	50.9	56.2	55.4	50.9
TGE 20	12.5	25	28.3	36.6	45.8	55.2	62.7	63.7	59.3
	16	25	34.2	44.3	55.7	67.5	77.2	79.0	73.8
	20	25	41.9	54.0	67.2	80.4	90.6	91.0	83.9
	21	25	56.3	71.2	85.6	97.4	103	97.4	87.4
TGE 40	26	25	54.4	70.7	89.5	109	126	131	123
	30	25	61.8	80.4	102	124	144	149	140
	40	25	74.1	96.4	123	153	178	182	168
	42	25	109	136	164	188	202	193	175

Capacity in TR. -40 – 60 °F
Opening superheat sh = 7.2 °F

US units R454B

Valve type	Orifice no.	Cond. temp. [°F]	Evaporating temperature [°F]						
			-40	-20	0	20	40	50	60
TGE 10	3	75	1.85	2.39	2.94	3.42	3.61	3.49	3.10
	4	75	2.51	3.24	4.00	4.66	4.94	4.77	4.24
	6	75	3.71	4.80	5.94	6.92	7.33	7.07	6.29
	8	75	5.04	6.52	8.05	9.35	9.83	9.45	8.35
	9	75	5.86	7.62	9.45	11.0	11.7	11.3	9.99
	11	75	7.43	9.72	12.0	13.6	13.8	12.9	11.2
	12.5	75	7.81	10.2	12.8	15.0	15.9	15.3	13.6
TGE 20	12.5	75	8.07	10.7	13.6	16.4	18.0	17.6	15.8
	16	75	9.74	12.9	16.5	20.1	22.2	21.8	19.8
	20	75	11.9	15.8	19.9	23.8	25.8	25.1	22.4
	21	75	15.9	20.6	25.0	28.1	28.5	26.8	23.2
TGE 40	26	75	15.5	20.7	26.7	32.7	36.6	36.3	33.0
	30	75	17.6	23.5	30.4	37.3	41.6	41.2	37.4
	40	75	21.1	28.3	36.9	45.8	51.2	50.1	44.7
	42	75	30.7	39.3	47.8	54.4	56.0	53.1	46.4

Capacity in kW. -40 – 15 °C
Opening superheat sh = 4 K

SI units R454B

Valve type	Orifice no.	Cond. temp. [°C]	Evaporating temperature [°C]						
			-40	-30	-20	-10	0	10	15
TGE 10	3	35	6.56	8.36	10.3	12.4	14.2	15.3	15.3
	4	35	8.81	11.3	13.9	16.7	19.2	20.8	20.8
	6	35	12.9	16.5	20.5	24.6	28.3	30.6	30.6
	8	35	17.3	22.2	27.5	33.0	37.9	40.6	40.5
	9	35	20.0	25.8	32.1	38.7	44.7	48.2	48.2
	11	35	25.4	33.2	41.6	49.7	55.7	57.3	55.7
	12.5	35	26.2	34.0	42.7	51.8	60.0	64.9	65.0
TGE 20	12.5	35	27.5	35.7	45.2	55.8	66.1	73.7	74.9
	16	35	33.0	42.9	54.6	67.7	80.9	90.8	92.6
	20	35	40.3	52.3	65.9	80.9	95.6	106	107
	21	35	56.6	72.6	88.8	104	115	118	115
TGE 40	26	35	51.7	67.6	86.5	108	131	148	152
	30	35	58.4	76.5	98.1	123	148	168	172
	40	35	70.1	91.7	119	152	187	213	217
	42	35	111	141	172	202	226	236	232

Capacity in TR. -40 – 60 °F
Opening superheat sh = 7.2 °F

US units R454B

Valve type	Orifice no.	Cond. temp. [°F]	Evaporating temperature [°F]						
			-40	-20	0	20	40	50	60
TGE 10	3	95	1.86	2.43	3.06	3.69	4.20	4.33	4.33
	4	95	2.50	3.28	4.14	5.00	5.71	5.90	5.90
	6	95	3.65	4.80	6.07	7.36	8.40	8.68	8.67
	8	95	4.91	6.46	8.17	9.88	11.2	11.5	11.5
	9	95	5.68	7.51	9.54	11.6	13.3	13.7	13.7
	11	95	7.22	9.70	12.4	14.8	16.2	16.3	15.7
	12.5	95	7.44	9.91	12.7	15.5	17.8	18.4	18.4
TGE 20	12.5	95	7.80	10.4	13.5	16.8	19.9	20.9	21.3
	16	95	9.36	12.5	16.3	20.5	24.4	25.8	26.3
	20	95	11.4	15.3	19.6	24.4	28.7	30.1	30.4
	21	95	16.1	21.1	26.2	30.7	33.4	33.6	32.6
TGE 40	26	95	14.7	19.7	25.9	32.9	39.6	42.1	43.2
	30	95	16.6	22.4	29.3	37.3	44.9	47.7	48.9
	40	95	19.9	26.8	35.7	46.4	57.0	60.6	61.6
	42	95	31.6	41.0	50.8	59.9	66.1	67.0	65.6

Subcooling correction factor 'fsub'

Subcooling [K]	2	4	10	15	20	25	30
Correction factor	0.98	1.00	1.06	1.12	1.17	1.22	1.27

Subcooling correction factor 'fsub'

Subcooling [°F]	2	7	10	20	30	40	50
Correction factor	0.97	1.00	1.02	1.08	1.13	1.19	1.25

Distributor correction factor 'fp' *

Pressure drop [bar] Δp	Evaporating temperature [°C]						
	-40	-30	-20	-10	0	10	15
0	1	1	1	1	1	1	1
1	0.97	0.97	0.97	0.96	0.96	0.94	0.93
1.5	0.96	0.95	0.95	0.94	0.93	0.91	0.89
2	0.94	0.94	0.93	0.92	0.91	0.88	0.85

*Calculated at 32 °C condensing temperature.

Distributor correction factor 'fp' *

Pressure drop [psi] Δp	Evaporating temperature [°F]						
	-40	-20	0	20	40	50	60
0	1	1	1	1	1	1	1
15	0.97	0.97	0.96	0.96	0.95	0.94	0.93
25	0.95	0.95	0.94	0.93	0.91	0.90	0.87
30	0.94	0.93	0.93	0.92	0.90	0.88	0.85

*calculated at 90 °F condensing temperature.



Data sheet | Thermostatic expansion valves, type TGE 10, TGE 20, TGE 40

Capacity in kW. -40 – 15 °C
Opening superheat sh = 4 K

SI units R454B

Valve type	Orifice no.	Cond. temp. [°C]	Evaporating temperature [°C]						
			-40	-30	-20	-10	0	10	15
TGE 10	3	45	6.44	8.25	10.3	12.5	14.6	16.5	17.1
	4	45	8.57	11.0	13.8	16.8	19.7	22.2	23.1
	6	45	12.4	15.9	20.0	24.4	28.8	32.5	33.7
	8	45	16.4	21.3	26.7	32.5	38.3	43.0	44.5
	9	45	18.9	24.6	31.0	37.9	44.9	50.8	52.7
	11	45	24.0	31.9	40.8	49.9	57.9	62.7	63.2
	12.5	45	24.4	31.9	40.6	50.0	59.5	67.4	70.1
TGE 20	12.5	45	26.1	33.9	43.1	53.6	64.9	75.3	79.4
	16	45	31.0	40.5	51.7	64.7	78.9	92.4	97.8
	20	45	37.8	49.2	62.4	77.4	93.6	109	115
	21	45	55.7	72.0	89.0	106	120	129	130
TGE 40	26	45	47.9	62.8	80.7	102	125	149	158
	30	45	53.9	70.8	91.2	115	142	168	179
	40	45	64.6	84.7	110	142	181	220	235
	42	45	112	142	175	208	238	259	263

Capacity in TR. -40 – 60 °F
Opening superheat sh = 7.2 °F

US units R454B

Valve type	Orifice no.	Cond. temp. [°F]	Evaporating temperature [°F]						
			-40	-20	0	20	40	50	60
TGE 10	3	115	1.82	2.40	3.05	3.75	4.41	4.69	4.89
	4	115	2.42	3.20	4.08	5.04	5.95	6.33	6.61
	6	115	3.49	4.62	5.92	7.33	8.68	9.23	9.64
	8	115	4.63	6.16	7.89	9.75	11.5	12.2	12.7
	9	115	5.32	7.11	9.17	11.4	13.5	14.4	15.1
	11	115	6.76	9.27	12.1	15.0	17.2	17.9	18.1
	12.5	115	6.85	9.24	12.0	15.0	17.9	19.1	20.0
TGE 20	12.5	115	7.35	9.82	12.8	16.2	19.7	21.3	22.6
	16	115	8.74	11.7	15.3	19.6	24.1	26.2	27.9
	20	115	10.6	14.2	18.5	23.3	28.5	30.9	32.8
	21	115	15.8	20.9	26.3	31.5	35.5	36.8	37.2
TGE 40	26	115	13.5	18.2	23.9	30.8	38.4	42.0	45.1
	30	115	15.1	20.5	27.0	34.8	43.4	47.4	50.9
	40	115	18.2	24.5	32.8	43.5	56.0	62.1	67.2
	42	115	31.8	41.4	51.8	62.2	70.9	73.9	75.4

Capacity in kW. -40 – 15 °C
Opening superheat sh = 4 K

SI units R454B

Valve type	Orifice no.	Cond. temp. [°C]	Evaporating temperature [°C]						
			-40	-30	-20	-10	0	10	15
TGE 10	3	55	6.19	7.96	9.96	12.2	14.4	16.5	17.4
	4	55	8.16	10.5	13.2	16.2	19.3	22.2	23.4
	6	55	11.6	15.0	19.0	23.3	27.8	32.0	33.8
	8	55	15.2	19.8	25.0	30.7	36.6	42.1	44.3
	9	55	17.4	22.8	28.9	35.7	42.8	49.5	52.3
	11	55	22.0	29.7	38.5	47.9	56.8	63.5	65.4
	12.5	55	22.1	29.2	37.4	46.5	56.0	64.9	68.7
TGE 20	12.5	55	24.3	31.5	40.0	49.8	60.6	71.5	76.5
	16	55	28.7	37.3	47.6	59.7	73.1	87.1	93.6
	20	55	34.8	45.3	57.4	71.4	86.9	103	111
	21	55	53.7	69.8	86.8	104	119	131	135
TGE 40	26	55	43.5	56.9	73.2	92.5	115	138	149
	30	55	48.7	63.9	82.3	104	129	156	168
	40	55	58.3	76.2	99.0	128	164	206	226
	42	55	111	141	174	208	240	266	274

Capacity in TR. -40 – 60 °F
Opening superheat sh = 7.2 °F

US units R454B

Valve type	Orifice no.	Cond. temp. [°F]	Evaporating temperature [°F]						
			-40	-20	0	20	40	50	60
TGE 10	3	135	1.74	2.29	2.93	3.63	4.34	4.66	4.94
	4	135	2.29	3.03	3.89	4.83	5.79	6.24	6.63
	6	135	3.24	4.32	5.56	6.93	8.34	8.99	9.56
	8	135	4.24	5.68	7.32	9.13	11.0	11.8	12.5
	9	135	4.84	6.52	8.46	10.6	12.8	13.8	14.7
	11	135	6.11	8.53	11.3	14.3	16.9	17.9	18.6
	12.5	135	6.13	8.34	10.9	13.8	16.7	18.1	19.3
TGE 20	12.5	135	6.76	9.02	11.7	14.8	18.2	19.9	21.5
	16	135	7.97	10.7	13.9	17.8	22.0	24.2	26.3
	20	135	9.66	12.9	16.8	21.2	26.1	28.7	31.1
	21	135	15.1	20.1	25.5	30.8	35.3	37.0	38.2
TGE 40	26	135	12.0	16.2	21.4	27.5	34.6	38.2	41.7
	30	135	13.5	18.2	24.0	31.0	39.0	43.1	47.0
	40	135	16.1	21.7	28.9	38.4	50.3	56.9	63.4
	42	135	31.2	40.8	51.2	61.8	71.5	75.3	78.1

Subcooling correction factor 'fsub'

Subcooling [K]	2	4	10	15	20	25	30
Correction factor	0.98	1.00	1.06	1.12	1.17	1.22	1.27

Subcooling correction factor 'fsub'

Subcooling [°F]	2	7	10	20	30	40	50
Correction factor	0.97	1.00	1.02	1.08	1.13	1.19	1.25

Distributor correction factor 'fp' *

Pressure drop [bar] Δp	Evaporating temperature [°C]						
	-40	-30	-20	-10	0	10	15
0	1	1	1	1	1	1	1
1	0.97	0.97	0.97	0.96	0.96	0.94	0.93
1.5	0.96	0.95	0.95	0.94	0.93	0.91	0.89
2	0.94	0.94	0.93	0.92	0.91	0.88	0.85

*Calculated at 32 °C condensing temperature.

Distributor correction factor 'fp' *

Pressure drop [psi] Δp	Evaporating temperature [°F]						
	-40	-20	0	20	40	50	60
0	1	1	1	1	1	1	1
15	0.97	0.97	0.96	0.96	0.95	0.94	0.93
25	0.95	0.95	0.94	0.93	0.91	0.90	0.87
30	0.94	0.93	0.93	0.92	0.90	0.88	0.85

*calculated at 90 °F condensing temperature.



Data sheet | Thermostatic expansion valves, type TGE 10, TGE 20, TGE 40

Capacity in kW. -40 – 15 °C
Opening superheat sh = 4 K

SI units R22

Valve type	Orifice no.	Cond. temp. [°C]	Evaporating temperature [°C]						
			-40	-30	-20	-10	0	10	15
TGE 10	3	25	4.39	5.68	7.02	8.22	8.97	8.70	7.90
	4	25	5.94	7.70	9.54	11.2	12.2	11.9	10.8
	6	25	8.76	11.4	14.1	16.6	18.1	17.5	15.9
	8	25	11.9	15.5	19.1	22.3	24.2	23.2	20.9
	9	25	13.9	18.1	22.5	26.4	28.8	27.7	25.0
	11	25	17.7	23.1	28.4	32.4	33.8	31.1	27.7
	12.5	25	17.8	23.2	29.0	34.2	37.5	36.4	32.7
TGE 20	12.5	25	16.5	21.9	28.0	34.1	38.7	38.9	36.0
	16	25	20.7	27.5	35.3	43.2	49.2	49.8	46.2
	20	25	25.6	33.7	42.7	51.5	57.7	57.1	52.3
	21	25	33.6	43.5	53.1	61.0	64.7	60.3	53.4
TGE 40	26	25	34.6	46.5	60.2	74.5	85.9	87.4	80.8
	30	25	39.4	52.9	68.6	84.8	97.7	99.1	91.5
	40	25	47.3	63.7	83.3	104	121	121	109
	42	25	67.2	86.8	107	124	132	125	111

Capacity in TR. -40 – 60 °F
Opening superheat sh = 7.2 °F

US units R22

Valve type	Orifice no.	Cond. temp. [°F]	Evaporating temperature [°F]						
			-40	-20	0	20	40	50	60
TGE 10	3	75	1.24	1.65	2.06	2.40	2.50	2.39	2.09
	4	75	1.68	2.24	2.80	3.27	3.42	3.27	2.86
	6	75	2.49	3.31	4.15	4.84	5.06	4.82	4.21
	8	75	3.38	4.50	5.62	6.51	6.74	6.39	5.54
	9	75	3.96	5.28	6.62	7.71	8.03	7.63	6.59
	11	75	5.02	6.73	8.30	9.31	9.21	8.55	7.33
	12.5	75	5.07	6.77	8.56	10.0	10.5	10.0	8.57
TGE 20	12.5	75	4.70	6.40	8.32	10.1	11.0	10.7	9.58
	16	75	5.89	8.05	10.5	12.8	14.1	13.7	12.3
	20	75	7.28	9.85	12.7	15.2	16.3	15.8	13.9
	21	75	9.51	12.6	15.5	17.6	17.8	16.6	14.0
TGE 40	26	75	9.86	13.6	18.0	22.3	24.7	24.1	21.5
	30	75	11.2	15.5	20.5	25.4	28.0	27.4	24.3
	40	75	13.5	18.7	25.0	31.3	34.5	33.2	28.9
	42	75	19.0	25.1	31.2	35.8	36.4	34.1	29.1

Capacity in kW. -40 – 15 °C
Opening superheat sh = 4 K

SI units R22

Valve type	Orifice no.	Cond. temp. [°C]	Evaporating temperature [°C]						
			-40	-30	-20	-10	0	10	15
TGE 10	3	35	4.44	5.81	7.30	8.79	10.1	10.7	10.6
	4	35	5.96	7.82	9.86	11.9	13.6	14.5	14.4
	6	35	8.69	11.4	14.5	17.5	20.0	21.3	21.1
	8	35	11.7	15.4	19.4	23.4	26.7	28.1	27.6
	9	35	13.6	18.0	22.7	27.6	31.6	33.6	33.2
	11	35	17.3	23.2	29.3	34.8	38.2	38.4	36.9
	12.5	35	17.3	22.9	29.2	35.4	40.6	43.2	43.0
TGE 20	12.5	35	16.3	21.7	28.1	35.1	41.8	46.1	46.5
	16	35	20.2	27.0	35.1	44.1	52.8	58.6	59.3
	20	35	25.0	33.1	42.5	52.8	62.4	68.1	68.2
	21	35	34.1	44.6	55.6	65.8	73.2	75.0	72.7
TGE 40	26	35	33.0	44.6	58.6	74.5	90.4	102	104
	30	35	37.4	50.6	66.5	84.6	103	115	117
	40	35	45.0	61.0	81.2	105	130	146	146
	42	35	69.3	90.4	113	134	151	156	152

Capacity in TR. -40 – 60 °F
Opening superheat sh = 7.2 °F

US units R22

Valve type	Orifice no.	Cond. temp. [°F]	Evaporating temperature [°F]						
			-40	-20	0	20	40	50	60
TGE 10	3	95	1.26	1.70	2.17	2.63	2.96	3.03	2.99
	4	95	1.69	2.28	2.93	3.56	4.03	4.12	4.07
	6	95	2.47	3.34	4.30	5.23	5.91	6.04	5.96
	8	95	3.32	4.49	5.77	6.99	7.84	7.98	7.82
	9	95	3.85	5.25	6.77	8.25	9.33	9.54	9.39
	11	95	4.92	6.78	8.70	10.3	11.0	10.9	10.4
	12.5	95	4.93	6.70	8.69	10.6	12.0	12.3	12.2
TGE 20	12.5	95	4.63	6.34	8.41	10.6	12.5	13.1	13.2
	16	95	5.75	7.90	10.5	13.4	15.9	16.7	16.8
	20	95	7.09	9.67	12.7	16.0	18.6	19.4	19.3
	21	95	9.67	13.0	16.5	19.5	21.3	21.3	20.5
TGE 40	26	95	9.37	13.1	17.6	22.7	27.4	28.9	29.4
	30	95	10.6	14.8	20.0	25.8	31.1	32.7	33.2
	40	95	12.8	17.9	24.5	32.3	39.3	41.3	41.3
	42	95	19.7	26.4	33.5	39.9	44.0	44.2	42.8

Subcooling correction factor 'fsub'

Subcooling [K]	2	4	10	15	20	25	30
Correction factor	0.98	1.00	1.05	1.10	1.14	1.18	1.23

Subcooling correction factor 'fsub'

Subcooling [°F]	2	7	10	20	30	40	50
Correction factor	0.98	1.00	1.01	1.06	1.11	1.16	1.21

Distributor correction factor 'fp' *

Pressure drop [bar] Δp	Evaporating temperature [°C]						
	-40	-30	-20	-10	0	10	15
0	1	1	1	1	1	1	1
1	0.96	0.95	0.95	0.94	0.93	0.91	0.89
1.5	0.93	0.93	0.92	0.91	0.90	0.86	0.82
2	0.91	0.90	0.90	0.88	0.86	0.81	0.76

*Calculated at 32 °C condensing temperature.

Distributor correction factor 'fp' *

Pressure drop [psi] Δp	Evaporating temperature [°F]						
	-40	-20	0	20	40	50	60
0	1	1	1	1	1	1	1
15	0.95	0.95	0.95	0.94	0.92	0.91	0.88
25	0.92	0.92	0.91	0.89	0.87	0.84	0.79
30	0.91	0.90	0.89	0.87	0.84	0.80	0.74

*calculated at 90 °F condensing temperature.



Data sheet | Thermostatic expansion valves, type TGE 10, TGE 20, TGE 40

Capacity in kW. -40 – 15 °C
Opening superheat sh = 4 K

SI units R22

Valve type	Orifice no.	Cond. temp. [°C]	Evaporating temperature [°C]						
			-40	-30	-20	-10	0	10	15
TGE 10	3	45	4.39	5.79	7.35	9.00	10.6	11.8	12.1
	4	45	5.84	7.73	9.85	12.1	14.3	15.9	16.4
	6	45	8.40	11.2	14.3	17.6	20.8	23.2	23.8
	8	45	11.2	14.9	19.0	23.4	27.5	30.5	31.2
	9	45	12.9	17.3	22.2	27.4	32.5	36.4	37.4
	11	45	16.5	22.5	29.1	35.5	40.6	42.9	42.7
	12.5	45	16.3	21.9	28.3	35.1	41.4	46.2	47.8
TGE 20	12.5	45	15.7	20.9	27.2	34.5	42.1	48.8	51.2
	16	45	19.4	25.8	33.7	42.9	52.8	61.6	64.8
	20	45	23.8	31.6	40.9	51.5	62.7	72.4	75.5
	21	45	33.8	44.7	56.3	67.9	77.8	83.6	84.2
TGE 40	26	45	30.8	41.7	55.1	71.0	88.5	105	111
	30	45	34.7	47.1	62.3	80.4	100	119	126
	40	45	41.7	56.7	76.1	101	129	155	164
	42	45	70.1	91.9	116	140	161	175	176

Capacity in TR. -40 – 60 °F
Opening superheat sh = 7.2 °F

US units R22

Valve type	Orifice no.	Cond. temp. [°F]	Evaporating temperature [°F]						
			-40	-20	0	20	40	50	60
TGE 10	3	115	1.24	1.69	2.19	2.71	3.19	3.37	3.48
	4	115	1.65	2.25	2.93	3.65	4.30	4.55	4.70
	6	115	2.37	3.25	4.25	5.30	6.26	6.61	6.83
	8	115	3.15	4.33	5.65	7.04	8.26	8.70	8.93
	9	115	3.63	5.02	6.60	8.26	9.79	10.4	10.7
	11	115	4.65	6.56	8.66	10.6	12.0	12.3	12.3
	12.5	115	4.59	6.36	8.42	10.6	12.4	13.2	13.7
TGE 20	12.5	115	4.45	6.08	8.11	10.5	12.9	13.9	14.7
	16	115	5.46	7.50	10.1	13.1	16.2	17.5	18.6
	20	115	6.72	9.17	12.2	15.6	19.1	20.6	21.6
	21	115	9.57	13.0	16.7	20.3	23.1	23.9	24.2
TGE 40	26	115	8.66	12.1	16.4	21.6	27.2	29.7	31.8
	30	115	9.76	13.7	18.6	24.5	30.8	33.6	35.9
	40	115	11.7	16.5	22.8	30.9	40.0	44.1	46.9
	42	115	19.9	26.9	34.5	42.1	48.1	50.0	50.6

Capacity in kW. -40 – 15 °C
Opening superheat sh = 4 K

SI units R22

Valve type	Orifice no.	Cond. temp. [°C]	Evaporating temperature [°C]						
			-40	-30	-20	-10	0	10	15
TGE 10	3	55	4.26	5.64	7.21	8.91	10.6	12.2	12.7
	4	55	5.61	7.46	9.57	11.9	14.2	16.3	17.1
	6	55	7.95	10.6	13.7	17.1	20.5	23.6	24.7
	8	55	10.4	14.0	18.1	22.5	27.0	30.9	32.2
	9	55	11.9	16.2	21.0	26.3	31.7	36.6	38.5
	11	55	15.3	21.2	27.9	34.8	40.9	44.9	45.7
	12.5	55	14.8	20.2	26.5	33.4	40.3	46.4	49.0
TGE 20	12.5	55	14.9	19.7	25.6	32.7	40.5	48.2	51.5
	16	55	18.2	24.1	31.5	40.3	50.3	60.2	64.6
	20	55	22.3	29.5	38.2	48.4	59.9	71.2	76.0
	21	55	32.9	43.7	55.6	67.7	78.9	87.3	89.6
TGE 40	26	55	28.2	38.1	50.4	65.3	82.4	100	109
	30	55	31.6	42.9	56.8	73.7	93.1	113	123
	40	55	37.8	51.4	69.1	92.1	120	151	165
	42	55	69.9	91.8	116	142	165	183	189

Capacity in TR. -40 – 60 °F
Opening superheat sh = 7.2 °F

US units R22

Valve type	Orifice no.	Cond. temp. [°F]	Evaporating temperature [°F]						
			-40	-20	0	20	40	50	60
TGE 10	3	135	1.20	1.64	2.14	2.68	3.22	3.45	3.64
	4	135	1.57	2.16	2.83	3.57	4.30	4.63	4.90
	6	135	2.22	3.07	4.05	5.13	6.19	6.66	7.05
	8	135	2.91	4.04	5.33	6.75	8.13	8.72	9.18
	9	135	3.32	4.65	6.19	7.87	9.57	10.3	11.0
	11	135	4.26	6.13	8.26	10.4	12.2	12.8	13.1
	12.5	135	4.09	5.78	7.80	10.0	12.1	13.1	14.0
TGE 20	12.5	135	4.19	5.68	7.57	9.84	12.3	13.5	14.6
	16	135	5.08	6.93	9.30	12.2	15.3	16.9	18.3
	20	135	6.22	8.46	11.2	14.6	18.2	20.0	21.6
	21	135	9.26	12.7	16.5	20.3	23.6	24.8	25.6
TGE 40	26	135	7.83	10.9	14.8	19.7	25.2	28.0	30.6
	30	135	8.77	12.3	16.7	22.2	28.4	31.6	34.6
	40	135	10.5	14.7	20.4	28.0	37.4	42.3	46.8
	42	135	19.8	26.7	34.5	42.5	49.6	52.3	54.1

Subcooling correction factor 'fsub'

Subcooling [K]	2	4	10	15	20	25	30
Correction factor	0.98	1.00	1.05	1.10	1.14	1.18	1.23

Subcooling correction factor 'fsub'

Subcooling [°F]	2	7	10	20	30	40	50
Correction factor	0.98	1.00	1.01	1.06	1.11	1.16	1.21

Distributor correction factor 'fp' *

Pressure drop [bar] Δp	Evaporating temperature [°C]						
	-40	-30	-20	-10	0	10	15
0	1	1	1	1	1	1	1
1	0.96	0.95	0.95	0.94	0.93	0.91	0.89
1.5	0.93	0.93	0.92	0.91	0.90	0.86	0.82
2	0.91	0.90	0.90	0.88	0.86	0.81	0.76

*Calculated at 32 °C condensing temperature.

Distributor correction factor 'fp' *

Pressure drop [psi] Δp	Evaporating temperature [°F]						
	-40	-20	0	20	40	50	60
0	1	1	1	1	1	1	1
15	0.95	0.95	0.95	0.94	0.92	0.91	0.88
25	0.92	0.92	0.91	0.89	0.87	0.84	0.79
30	0.91	0.90	0.89	0.87	0.84	0.80	0.74

*Calculated at 90 °F condensing temperature.



Data sheet | Thermostatic expansion valves, type TGE 10, TGE 20, TGE 40

Capacity in kW. -40 – 15 °C.
Opening superheat sh = 4 K

SI units R134a

Valve type	Orifice no.	Cond. temp. [°C]	Evaporating temperature [°C]						
			-40	-30	-20	-10	0	10	15
TGE 10	3	25	2.44	3.10	3.85	4.62	5.23	5.31	4.92
	4	25	3.33	4.24	5.27	6.33	7.18	7.30	6.77
	6	25	5.00	6.37	7.92	9.52	10.8	11.0	10.2
	8	25	6.90	8.78	10.9	13.1	14.7	14.9	13.7
	9	25	8.11	10.3	12.8	15.4	17.5	17.8	16.4
	11	25	10.5	13.0	16.1	19.1	21.2	20.8	18.9
	12.5	25	11.2	14.1	17.5	21.0	23.8	24.2	22.3
TGE 20	12.5	25	10.6	14.0	17.9	22.3	26.1	27.3	25.6
	16	25	13.4	17.6	22.7	28.4	33.4	35.0	32.9
	20	25	16.6	21.8	27.8	34.2	39.6	40.8	37.9
	21	25	21.0	27.1	33.9	40.5	45.0	44.0	39.8
TGE 40	26	25	22.1	29.1	37.6	47.2	55.9	59.2	56.0
	30	25	25.3	33.3	43.0	53.9	63.8	67.5	63.8
	40	25	30.5	40.0	51.7	65.0	77.5	81.9	76.6
	42	25	39.7	50.8	63.7	76.7	86.1	85.7	78.2

Capacity in TR. -40 – 60 °F
Opening superheat sh = 7.2 °F

US units R134a

Valve type	Orifice no.	Cond. temp. [°F]	Evaporating temperature [°F]						
			-40	-20	0	20	40	50	60
TGE 10	3	75	0.69	0.90	1.14	1.36	1.49	1.46	1.30
	4	75	0.94	1.23	1.56	1.87	2.05	2.01	1.79
	6	75	1.42	1.85	2.34	2.81	3.08	3.01	2.69
	8	75	1.96	2.55	3.22	3.85	4.20	4.09	3.64
	9	75	2.30	2.99	3.79	4.56	5.00	4.90	4.33
	11	75	2.89	3.77	4.74	5.61	5.95	5.70	4.98
	12.5	75	3.19	4.10	5.16	6.20	6.80	6.66	5.89
TGE 20	12.5	75	3.02	4.07	5.35	6.68	7.56	7.51	6.81
	16	75	3.81	5.16	6.79	8.51	9.68	9.65	8.77
	20	75	4.71	6.36	8.27	10.2	11.4	11.2	10.1
	21	75	5.94	7.86	10.0	11.9	12.6	12.1	10.5
TGE 40	26	75	6.30	8.53	11.3	14.2	16.3	16.4	15.0
	30	75	7.20	9.76	12.9	16.2	18.6	18.7	17.0
	40	75	8.70	11.7	15.5	19.6	22.6	22.6	20.3
	42	75	11.2	14.7	18.8	22.6	24.3	23.5	20.6

Capacity in kW. -40 – 15 °C.
Opening superheat sh = 4 K

SI units R134a

Valve type	Orifice no.	Cond. temp. [°C]	Evaporating temperature [°C]						
			-40	-30	-20	-10	0	10	15
TGE 10	3	35	2.46	3.16	3.99	4.92	5.84	6.49	6.59
	4	35	3.34	4.29	5.43	6.70	7.97	8.89	9.02
	6	35	4.96	6.39	8.09	10.0	11.9	13.3	13.5
	8	35	6.79	8.75	11.1	13.6	16.5	17.9	18.1
	9	35	7.99	10.3	13.0	16.1	19.1	21.2	21.5
	11	35	9.95	12.9	16.4	20.2	23.6	25.4	25.3
	12.5	35	11.0	13.9	17.6	21.6	25.7	28.6	29.0
TGE 20	12.5	35	10.5	13.8	18.0	22.9	28.2	32.4	33.3
	16	35	13.1	17.3	22.6	29.0	35.7	41.3	42.6
	20	35	16.1	21.4	27.7	35.0	42.6	48.4	49.5
	21	35	21.2	27.7	35.3	43.3	50.2	53.8	53.4
TGE 40	26	35	21.2	28.1	36.9	47.4	59.0	68.7	71.3
	30	35	24.1	32.1	42.0	54.1	67.2	78.3	81.1
	40	35	29.2	38.6	50.6	65.5	82.3	96.6	99.9
	42	35	40.7	52.7	67.0	82.6	96.8	105	106

Capacity in TR. -40 – 60 °F
Opening superheat sh = 7.2 °F

US units R134a

Valve type	Orifice no.	Cond. temp. [°F]	Evaporating temperature [°F]						
			-40	-20	0	20	40	50	60
TGE 10	3	95	0.70	0.92	1.19	1.49	1.76	1.84	1.87
	4	95	0.95	1.25	1.62	2.03	2.40	2.52	2.56
	6	95	1.41	1.87	2.41	3.03	3.58	3.77	3.82
	8	95	1.93	2.55	3.30	4.12	4.86	5.09	5.14
	9	95	2.27	2.99	3.88	4.86	5.73	6.02	6.10
	11	95	2.83	3.77	4.89	6.08	7.02	7.23	7.15
	12.5	95	3.11	4.06	5.23	6.54	7.72	8.11	8.24
TGE 20	12.5	95	2.97	4.04	5.40	7.01	8.60	9.19	9.47
	16	95	3.71	5.07	6.80	8.87	10.9	11.7	12.1
	20	95	4.58	6.25	8.30	10.7	12.9	13.7	14.1
	21	95	6.02	8.10	10.5	13.0	14.9	15.3	15.1
TGE 40	26	95	6.02	8.23	11.1	14.6	18.1	19.5	20.3
	30	95	6.85	9.38	12.7	16.6	20.6	22.22	23.1
	40	95	8.29	11.3	15.2	20.2	25.4	27.4	28.4
	42	95	11.6	15.4	20.0	24.9	28.9	29.9	29.9

Subcooling correction factor 'fsub'

Subcooling [K]	2	4	10	15	20	25	30
Correction factor	0.98	1.00	1.06	1.11	1.16	1.21	1.26

Subcooling correction factor 'fsub'

Subcooling [°F]	2	7	10	20	30	40	50
Correction factor	0.97	1.00	1.02	1.07	1.13	1.19	1.24

Distributor correction factor 'fp' *

Pressure drop [bar] Δp	Evaporating temperature [°C]						
	-40	-30	-20	-10	0	10	15
0	1	1	1	1	1	1	1
1	0.93	0.93	0.92	0.92	0.90	0.87	0.83
1.5	0.90	0.89	0.88	0.87	0.84	0.79	0.74
2	0.86	0.85	0.84	0.82	0.79	0.71	0.62

*Calculated at 32 °C condensing temperature.

Distributor correction factor 'fp' *

Pressure drop [psi] Δp	Evaporating temperature [°F]						
	-40	-20	0	20	40	50	60
0	1	1	1	1	1	1	1
15	0.93	0.93	0.92	0.91	0.89	0.86	0.82
25	0.88	0.87	0.86	0.84	0.80	0.76	0.68
30	0.86	0.85	0.83	0.81	0.75	0.70	0.60

*Calculated at 90 °F condensing temperature.



Data sheet | Thermostatic expansion valves, type TGE 10, TGE 20, TGE 40

Capacity in kW. -40 – 15 °C.
Opening superheat sh = 4 K

SI units R134a

Valve type	Orifice no.	Cond. temp. [°C]	Evaporating temperature [°C]						
			-40	-30	-20	-10	0	10	15
TGE 10	3	45	2.41	3.12	3.98	5.00	6.10	7.13	7.52
	4	45	3.25	4.21	5.39	6.78	8.29	9.71	10.3
	6	45	4.78	6.21	7.96	10.0	12.3	14.4	15.2
	8	45	6.48	8.44	10.8	13.5	16.6	19.4	20.4
	9	45	7.60	9.85	12.7	15.0	19.5	22.7	23.9
	11	45	9.44	12.4	16.1	20.3	24.6	28.1	29.0
	12.5	45	10.3	13.3	17.0	21.3	26.1	30.4	32.1
TGE 20	16	45	12.1	15.6	19.9	24.9	30.3	35.3	37.1
	12.5	45	10.0	13.3	17.4	22.5	28.3	34.2	36.6
	16	45	12.4	16.5	21.7	28.1	35.6	43.3	46.5
	20	45	15.3	20.3	26.5	34.0	42.6	51.1	54.5
TGE 40	21	45	20.8	27.4	35.5	44.3	52.8	59.2	60.9
	26	45	19.7	26.2	34.7	45.3	58.0	71.0	76.7
	30	45	22.3	29.8	39.4	51.6	65.9	80.7	87.1
	40	45	27.0	35.9	47.6	62.7	81.4	102	110
	42	45	40.6	52.9	68.0	85.3	103	117	121

Capacity in TR. -40 – 60 °F
Opening superheat sh = 7.2 °F

US units R134a

Valve type	Orifice no.	Cond. temp. [°F]	Evaporating temperature [°F]						
			-40	-20	0	20	40	50	60
TGE 10	3	115	0.68	0.91	1.19	1.52	1.88	2.04	2.16
	4	115	0.92	1.23	1.61	2.06	2.55	2.77	2.95
	6	115	1.35	1.81	2.37	3.05	3.78	4.10	4.36
	8	115	1.83	2.45	3.22	4.13	5.09	5.52	5.85
	9	115	2.14	2.86	3.78	4.86	5.98	6.47	6.87
	11	115	2.66	3.61	4.80	6.18	7.51	8.02	8.33
	12.5	115	2.90	3.84	5.05	6.48	7.99	8.66	9.20
TGE 20	16	115	3.40	4.51	5.91	7.55	9.27	10.0	10.7
	12.5	115	2.83	3.85	5.20	6.88	8.79	9.72	10.5
	16	115	3.50	4.79	6.48	8.62	11.1	12.3	13.3
	20	115	4.30	5.89	7.92	10.4	13.2	14.5	15.6
TGE 40	21	115	5.88	8.00	10.6	13.4	16.0	16.9	17.5
	26	115	5.53	7.61	10.4	13.9	18.1	20.1	22.0
	30	115	6.26	8.64	11.8	15.8	20.5	22.9	24.9
	40	115	7.59	10.4	14.2	19.3	25.6	28.9	31.6
	42	115	11.5	15.4	20.4	25.9	31.2	33.3	34.8

Capacity in kW. -40 – 15 °C.
Opening superheat sh = 4 K

SI units R134a

Valve type	Orifice no.	Cond. temp. [°C]	Evaporating temperature [°C]						
			-40	-30	-20	-10	0	10	15
TGE 10	3	55	2.31	3.00	3.86	4.89	6.07	7.29	7.85
	4	55	3.09	4.02	5.18	6.59	8.20	9.88	10.6
	6	55	4.48	5.86	7.57	9.65	12.0	14.5	15.7
	8	55	6.00	7.88	10.2	13.0	16.2	19.5	20.9
	9	55	6.95	9.11	11.9	15.2	19.0	22.8	24.6
	11	55	8.68	11.6	15.2	19.6	24.4	28.8	30.5
	12.5	55	9.30	12.1	15.7	20.1	25.2	30.3	32.7
TGE 20	16	55	10.9	14.2	18.4	23.5	29.3	35.3	38.0
	12.5	55	9.41	12.4	16.3	21.1	27.0	33.5	36.6
	16	55	11.5	15.3	20.1	26.2	33.7	42.0	46.1
	20	55	14.1	18.7	24.6	31.8	40.4	49.9	54.4
TGE 40	21	55	19.7	26.3	34.4	43.7	53.1	61.2	64.3
	26	55	17.7	23.7	31.5	41.5	53.9	68.0	74.9
	30	55	20.0	26.8	35.6	47.0	61.1	77.1	85.0
	40	55	24.2	32.3	43.0	57.2	75.9	98.5	110
	42	55	39.3	51.6	67.0	85.0	104.0	121	128

Capacity in TR. -40 – 60 °F
Opening superheat sh = 7.2 °F

US units R134a

Valve type	Orifice no.	Cond. temp. [°F]	Evaporating temperature [°F]						
			-40	-20	0	20	40	50	60
TGE 10	3	135	0.65	0.87	1.14	1.48	1.87	2.06	2.25
	4	135	0.86	1.16	1.53	2.00	2.52	2.79	3.04
	6	135	1.25	1.68	2.24	2.92	3.70	4.10	4.46
	8	135	1.67	2.26	3.00	3.92	4.96	5.48	5.96
	9	135	1.92	2.60	3.49	4.60	5.83	6.44	7.01
	11	135	2.41	3.32	4.49	5.92	7.46	8.16	8.71
	12.5	135	2.56	3.45	4.61	6.06	7.71	8.54	9.30
TGE 20	16	135	3.00	4.05	5.40	7.08	8.98	9.93	10.8
	12.5	135	2.62	3.56	4.81	6.41	8.35	9.39	10.4
	16	135	3.21	4.37	5.93	7.96	10.4	11.8	13.1
	20	135	3.91	5.37	7.24	9.60	12.4	14.0	15.4
TGE 40	21	135	5.51	7.59	10.2	13.2	16.1	17.4	18.4
	26	135	4.90	6.76	9.27	12.6	16.7	18.9	21.2
	30	135	5.51	7.63	10.5	14.2	18.9	21.5	24.0
	40	135	6.67	9.20	12.7	17.4	23.8	27.5	31.2
	42	135	11.0	15.0	20.0	25.8	31.8	34.5	36.9

Subcooling correction factor 'fsub'

Subcooling [K]	2	4	10	15	20	25	30
Correction factor	0.98	1.00	1.06	1.11	1.16	1.21	1.26

Subcooling correction factor 'fsub'

Subcooling [°F]	2	7	10	20	30	40	50
Correction factor	0.97	1.00	1.02	1.07	1.13	1.19	1.24

Distributor correction factor 'fp' *

Pressure drop [bar] Δp	Evaporating temperature [°C]						
	-40	-30	-20	-10	0	10	15
0	1	1	1	1	1	1	1
1	0.93	0.93	0.92	0.92	0.90	0.87	0.83
1.5	0.90	0.89	0.88	0.87	0.84	0.79	0.74
2	0.86	0.85	0.84	0.82	0.79	0.71	0.62

*Calculated at 32 °C condensing temperature.

Distributor correction factor 'fp' *

Pressure drop [psi] Δp	Evaporating temperature [°F]						
	-40	-20	0	20	40	50	60
0	1	1	1	1	1	1	1
15	0.93	0.93	0.92	0.91	0.89	0.86	0.82
25	0.88	0.87	0.86	0.84	0.80	0.76	0.68
30	0.86	0.85	0.83	0.81	0.75	0.70	0.60

*Calculated at 90 °F condensing temperature.



Data sheet | Thermostatic expansion valves, type TGE 10, TGE 20, TGE 40

Capacity in kW. -30 – 10 °C.

Opening superheat sh = 4 K

SI units R1234ze

Valve type	Orifice no.	Cond. temp. [°C]	Evaporating temperature [°C]				
			-30	-20	-10	0	10
TGE 10	3	25	2.45	3.20	3.94	4.51	4.56
	4	25	3.33	4.36	5.39	6.19	6.28
	6	25	4.97	6.52	8.07	9.25	9.35
	8	25	6.79	8.91	11.0	12.6	12.6
	9	25	7.94	10.5	13.0	14.9	15.0
	11	25	10.0	13.2	16.1	18.0	17.4
	12.5	25	10.7	14.2	17.7	20.3	20.5
TGE 20	12.5	25	5.52	9.56	14.2	18.7	20.7
	16	25	6.86	12.0	18.0	23.8	26.6
	20	25	8.82	15.3	22.1	28.3	31.0
	21	25	9.57	19.0	27.2	32.9	33.8
TGE 40	26	25	20.1	28.1	37.1	45.6	48.8
	30	25	22.9	32.0	42.4	52.0	55.6
	40	25	27.5	38.5	51.3	63.4	67.4
	42	25	35.6	47.7	59.8	68.7	69.1

Capacity in TR. -22 – 50 °F

Opening superheat sh = 7.2 °F

US units R1234ze

Valve type	Orifice no.	Cond. temp. [°F]	Evaporating temperature [°F]					
			-30	-20	0	20	40	50
TGE 10	3	75	0.61	0.72	0.95	1.17	1.28	1.25
	4	75	0.82	0.97	1.30	1.60	1.77	1.72
	6	75	1.23	1.46	1.94	2.40	2.64	2.57
	8	75	1.68	1.99	2.66	3.27	3.57	3.46
	9	75	1.96	2.33	3.12	3.86	4.24	4.12
	11	75	2.48	2.95	3.93	4.75	5.02	4.76
	12.5	75	2.63	3.14	4.23	5.26	5.80	5.63
TGE 20	12.5	75	1.13	1.69	2.99	4.46	5.60	5.71
	16	75	1.40	2.10	3.77	5.65	7.15	7.32
	20	75	1.78	2.71	4.76	6.86	8.41	8.54
	21	75	1.49	3.03	5.93	8.28	9.48	9.29
TGE 40	26	75	4.88	5.97	8.53	11.4	13.4	13.5
	30	75	5.56	6.80	9.73	13.0	15.3	15.3
	40	75	6.67	8.16	11.7	15.7	18.6	18.5
	42	75	8.65	10.4	14.2	17.8	19.5	18.9

Capacity in kW. -30 – 10 °C.

Opening superheat sh = 4 K

SI units R1234ze

Valve type	Orifice no.	Cond. temp. [°C]	Evaporating temperature [°C]				
			-30	-20	-10	0	10
TGE 10	3	35	2.46	3.28	4.17	5.01	5.60
	4	35	3.32	4.44	5.66	6.83	7.65
	6	35	4.90	6.59	8.42	10.2	11.4
	8	35	6.64	8.93	11.4	13.7	15.3
	9	35	7.72	10.4	13.4	16.2	18.2
	11	35	9.82	13.3	17.0	20.1	21.5
	12.5	35	10.2	14.0	18.0	22.0	24.6
TGE 20	12.5	35	5.35	9.41	14.4	19.8	24.4
	16	35	6.55	11.7	18.0	25.0	31.0
	20	35	8.06	14.7	22.1	29.8	36.2
	21	35	9.04	19.3	28.7	36.6	41.4
TGE 40	26	35	19.1	27.0	36.7	47.4	56.7
	30	35	21.6	30.6	41.7	54.0	64.4
	40	35	25.9	36.9	50.8	66.9	80.6
	42	35	36.3	49.6	64.0	77.3	85.5

Capacity in TR. -22 – 50 °F

Opening superheat sh = 7.2 °F

US units R1234ze

Valve type	Orifice no.	Cond. temp. [°F]	Evaporating temperature [°F]					
			-30	-20	0	20	40	50
TGE 10	3	95	0.60	0.72	0.99	1.27	1.51	1.59
	4	95	0.82	0.98	1.34	1.72	2.06	2.17
	6	95	1.20	1.44	1.98	2.56	3.07	3.23
	8	95	1.62	1.95	2.69	3.47	4.14	4.34
	9	95	1.88	2.27	3.14	4.08	4.90	5.15
	11	95	2.38	2.89	4.02	5.15	5.96	6.10
	12.5	95	2.49	3.02	4.21	5.51	6.64	6.99
TGE 20	12.5	95	1.09	1.63	2.96	4.59	6.27	6.94
	16	95	1.31	2.01	3.69	5.76	7.93	8.81
	20	95	1.54	2.48	4.62	7.00	9.35	10.3
	21	95	1.25	2.89	6.09	8.97	11.1	11.8
TGE 40	26	95	4.58	5.64	8.23	11.4	14.8	16.1
	30	95	5.18	6.39	9.35	13.0	16.8	18.3
	40	95	6.21	7.66	11.3	15.9	20.9	22.9
	42	95	8.80	10.7	15.0	19.5	23.3	24.3

Subcooling correction factor 'fsub'

Subcooling [K]	2	4	10	15	20	25	30
Correction factor	0.98	1.00	1.06	1.12	1.17	1.22	1.29

Subcooling correction factor 'fsub'

Subcooling [°F]	2	7	10	20	30	40	50
Correction factor	0.97	1.00	1.02	1.08	1.14	1.20	1.27

Distributer correction factor 'fp' *

Pressure drop [bar] Δp	Evaporating temperature [°C]				
	-30	-20	-10	0	10
0	1	1	1	1	1
1	0.90	0.90	0.89	0.86	0.82
1.5	0.85	0.84	0.82	0.79	0.71
2	0.80	0.78	0.75	0.70	0.59

*Calculated at 32 °C condensing temperature.

Distributer correction factor 'fp' *

Pressure drop [psi] Δp	Evaporating temperature [°F]					
	-30	-20	0	20	40	50
0	1	1	1	1	1	1
15	0.90	0.90	0.89	0.88	0.85	0.81
25	0.83	0.83	0.81	0.78	0.72	0.66
30	0.80	0.79	0.77	0.73	0.65	0.57

*Calculated at 90 °F condensing temperature.



Data sheet | Thermostatic expansion valves, type TGE 10, TGE 20, TGE 40

Capacity in kW. -30 – 10 °C.
Opening superheat sh = 4 K

SI units R1234ze

Valve type	Orifice no.	Cond. temp. [°C]	Evaporating temperature [°C]				
			-30	-20	-10	0	10
TGE 10	3	45	2.40	3.24	4.20	5.20	6.10
	4	45	3.22	4.37	5.67	7.03	8.27
	6	45	4.68	6.39	8.34	10.4	12.2
	8	45	6.27	8.58	11.2	14.0	16.4
	9	45	7.24	9.97	13.1	16.4	19.4
	11	45	9.25	12.9	17.0	20.9	23.7
	12.5	45	9.46	13.2	17.4	22.0	26.1
TGE 20	12.5	45	5.02	8.96	13.9	19.5	25.3
	16	45	6.07	11.0	17.2	24.4	31.7
	20	45	7.02	13.5	21.0	29.2	37.3
	21	45	8.12	18.7	29.0	38.1	45.3
TGE 40	26	45	17.5	25.0	34.4	45.7	57.4
	30	45	19.7	28.3	39.0	51.8	65.1
	40	45	23.6	34.0	47.6	64.9	83.6
	42	45	36.1	50.0	65.5	81.4	94.4

Capacity in TR. -22 – 50 °F
Opening superheat sh = 7.2 °F

US units R1234ze

Valve type	Orifice no.	Cond. temp. [°F]	Evaporating temperature [°F]					
			-30	-20	0	20	40	50
TGE 10	3	115	0.58	0.70	0.98	1.29	1.60	1.74
	4	115	0.78	0.94	1.31	1.73	2.16	2.36
	6	115	1.13	1.37	1.92	2.55	3.20	3.49
	8	115	1.51	1.83	2.58	3.43	4.29	4.66
	9	115	1.73	2.12	3.00	4.01	5.05	5.51
	11	115	2.20	2.71	3.89	5.19	6.35	6.76
	12.5	115	2.25	2.76	3.96	5.35	6.78	7.40
TGE 20	12.5	115	1.00	1.52	2.81	4.42	6.27	7.16
	16	115	1.18	1.84	3.45	5.49	7.83	8.98
	20	115	1.23	2.15	4.24	6.67	9.30	10.6
	21	115	0.91	2.61	5.96	9.12	11.9	12.9
TGE 40	26	115	4.14	5.12	7.55	10.7	14.4	16.2
	30	115	4.66	5.77	8.54	12.1	16.3	18.4
	40	115	5.56	6.90	10.3	14.9	20.7	23.7
	42	115	8.69	10.6	15.1	20.2	25.0	27.0

Capacity in kW. -30 – 10 °C.
Opening superheat sh = 4 K

SI units R1234ze

Valve type	Orifice no.	Cond. temp. [°C]	Evaporating temperature [°C]				
			-30	-20	-10	0	10
TGE 10	3	55	2.28	3.11	4.07	5.13	6.18
	4	55	3.05	4.18	5.48	6.90	8.32
	6	55	4.34	6.00	7.94	10.1	12.2
	8	55	5.74	7.97	10.57	13.4	16.2
	9	55	6.58	9.21	12.3	15.7	19.1
	11	55	8.41	12.0	16.2	20.5	24.1
	12.5	55	8.45	12.0	16.1	20.8	25.4
TGE 20	12.5	55	4.61	8.31	12.9	18.4	24.2
	16	55	5.47	10.1	15.8	22.7	30.1
	20	55	5.80	12.0	19.2	27.2	35.7
	21	55	6.95	17.7	28.2	37.9	46.3
TGE 40	26	55	15.7	22.4	31.1	41.7	53.7
	30	55	17.6	25.2	35.1	47.1	60.6
	40	55	20.9	30.2	42.7	59.0	78.8
	42	55	35.2	49.0	64.9	81.8	97.4

Capacity in TR. -22 – 50 °F
Opening superheat sh = 7.2 °F

US units R1234ze

Valve type	Orifice no.	Cond. temp. [°F]	Evaporating temperature [°F]					
			-30	-20	0	20	40	50
TGE 10	3	135	0.54	0.66	0.93	1.24	1.58	1.75
	4	135	0.73	0.89	1.25	1.67	2.12	2.35
	6	135	1.02	1.25	1.79	2.41	3.10	3.43
	8	135	1.34	1.65	2.37	3.21	4.11	4.55
	9	135	1.53	1.90	2.74	3.73	4.82	5.36
	11	135	1.94	2.43	3.59	4.93	6.26	6.82
	12.5	135	1.95	2.43	3.55	4.90	6.38	7.11
TGE 20	12.5	135	0.90	1.38	2.58	4.08	5.85	6.76
	16	135	1.03	1.64	3.13	5.00	7.22	8.38
	20	135	0.88	1.75	3.73	6.04	8.62	9.95
	21	135	0.53	2.23	5.61	8.87	11.8	13.1
TGE 40	26	135	3.64	4.51	6.68	9.52	13.0	14.8
	30	135	4.06	5.05	7.51	10.7	14.7	16.8
	40	135	4.82	5.99	9.00	13.1	18.7	21.8
	42	135	8.38	10.3	14.8	19.9	25.2	27.7

Subcooling correction factor 'fsub'

Subcooling [K]	2	4	10	15	20	25	30
Correction factor	0.98	1.00	1.06	1.12	1.17	1.22	1.29

Subcooling correction factor 'fsub'

Subcooling [°F]	2	7	10	20	30	40	50
Correction factor	0.97	1.00	1.02	1.08	1.14	1.20	1.27

Distributer correction factor 'fp' *

Pressure drop [bar] Δp	Evaporating temperature [°C]				
	-30	-20	-10	0	10
0	1	1	1	1	1
1	0.90	0.90	0.89	0.86	0.82
1.5	0.85	0.84	0.82	0.79	0.71
2	0.80	0.78	0.75	0.70	0.59

*Calculated at 32 °C condensing temperature.

Distributer correction factor 'fp' *

Pressure drop [psi] Δp	Evaporating temperature [°F]					
	-30	-20	0	20	40	50
0	1	1	1	1	1	1
15	0.90	0.90	0.89	0.88	0.85	0.81
25	0.83	0.83	0.81	0.78	0.72	0.66
30	0.80	0.79	0.77	0.73	0.65	0.57

*Calculated at 90 °F condensing temperature.



Data sheet | Thermostatic expansion valves, type TGE 10, TGE 20, TGE 40

Capacity in kW. -40 – 15 °C.
Opening superheat sh = 4 K

SI units R407F

Valve type	Orifice no.	Cond. temp. [°C]	Evaporating temperature [°C]						
			-40	-30	-20	-10	0	10	15
TGE 10	3	25	4.75	5.89	7.19	8.52	9.61	9.98	9.64
	4	25	6.42	7.97	9.75	11.6	13.1	13.6	13.2
	6	25	9.46	11.8	14.4	17.1	19.3	20.1	19.5
	8	25	12.9	16.0	19.5	23.1	25.9	26.8	25.8
	9	25	15.0	18.7	22.9	27.2	30.7	31.9	30.8
	11	25	19.0	23.8	29.1	34.0	37.1	36.8	34.7
	12.5	25	20.0	25.0	30.7	36.5	41.4	43.1	41.8
TGE 20	12.5	25	19.4	24.7	31.0	37.9	44.3	47.8	47.1
	16	25	24.2	30.9	38.9	47.8	56.1	60.8	60.2
	20	25	29.8	37.7	47.1	57.0	65.9	70.1	68.6
	21	25	39.8	49.7	60.3	69.9	76.2	75.6	71.3
TGE 40	26	25	39.0	49.9	63.3	78.3	92.7	102	101
	30	25	44.3	56.8	72.0	89.0	105	115	115
	40	25	53.3	68.5	87.6	110	132	143	139
	42	25	78.0	96.6	117	137	151	152	144

Capacity in TR. -40 – 60 °F
Opening superheat sh = 7.2 °F

US units R407F

Valve type	Orifice no.	Cond. temp. [°F]	Evaporating temperature [°F]						
			-40	-20	0	20	40	50	60
TGE 10	3	75	1.35	1.71	2.12	2.52	2.77	2.78	2.63
	4	75	1.82	2.32	2.88	3.42	3.78	3.79	3.60
	6	75	2.69	3.42	4.26	5.07	5.59	5.60	5.32
	8	75	3.66	4.65	5.76	6.82	7.47	7.46	7.06
	9	75	4.27	5.44	6.77	8.05	8.88	8.89	8.44
	11	75	5.40	6.92	8.56	9.94	10.5	10.2	9.44
	12.5	75	5.69	7.28	9.09	10.9	12.0	12.0	11.5
TGE 20	12.5	75	5.53	7.21	9.23	11.4	13.1	13.4	12.9
	16	75	6.90	9.02	11.6	14.4	16.6	17.0	16.6
	20	75	8.49	11.0	14.0	17.1	19.3	19.6	18.8
	21	75	11.3	14.4	17.7	20.4	21.6	21.0	19.4
TGE 40	26	75	11.1	14.6	18.9	23.7	27.6	28.5	28.0
	30	75	12.7	16.6	21.5	27.0	31.3	32.3	31.7
	40	75	15.2	20.1	26.3	33.3	39.0	39.7	38.0
	42	75	22.1	28.0	34.3	40.1	43.1	42.3	39.2

Capacity in kW. -40 – 15 °C.
Opening superheat sh = 4 K

SI units R407F

Valve type	Orifice no.	Cond. temp. [°C]	Evaporating temperature [°C]						
			-40	-30	-20	-10	0	10	15
TGE 10	3	35	4.68	5.85	7.24	8.76	10.2	11.2	11.5
	4	35	6.28	7.88	9.76	11.8	13.8	15.3	15.6
	6	35	9.17	11.5	14.3	17.4	20.3	22.4	22.8
	8	35	12.4	15.5	19.3	23.3	27.1	29.7	30.2
	9	35	14.4	18.1	22.5	27.4	32.0	35.2	35.9
	11	35	18.3	23.3	29.1	35.0	39.7	41.8	41.5
	12.5	35	18.9	23.9	29.9	36.5	42.7	47.2	48.2
TGE 20	12.5	35	18.7	23.9	30.3	37.7	45.3	51.6	53.6
	16	35	23.1	29.6	37.8	47.2	57.0	65.2	67.9
	20	35	28.4	36.2	45.8	56.5	67.4	76.0	78.5
	21	35	39.3	49.7	61.2	72.5	81.7	86.0	85.6
TGE 40	26	35	36.6	47.2	60.5	76.2	92.8	107	112
	30	35	41.5	53.5	68.7	86.5	105	121	127
	40	35	49.3	63.8	82.6	106	133	157	163
	42	35	78.2	97.7	120	143	163	174	174

Capacity in TR. -40 – 60 °F
Opening superheat sh = 7.2 °F

US units R407F

Valve type	Orifice no.	Cond. temp. [°F]	Evaporating temperature [°F]						
			-40	-20	0	20	40	50	60
TGE 10	3	95	1.33	1.70	2.15	2.63	3.05	3.19	3.26
	4	95	1.78	2.29	2.90	3.56	4.13	4.33	4.43
	6	95	2.60	3.36	4.25	5.22	6.06	6.35	6.49
	8	95	3.51	4.52	5.72	6.99	8.07	8.43	8.57
	9	95	4.08	5.27	6.70	8.22	9.55	10.0	10.2
	11	95	5.19	6.78	8.63	10.4	11.7	11.9	11.8
	12.5	95	5.37	6.97	8.89	11.0	12.8	13.4	13.7
TGE 20	12.5	95	5.30	6.97	9.05	11.4	13.7	14.7	15.3
	16	95	6.55	8.65	11.3	14.3	17.3	18.5	19.4
	20	95	8.05	10.7	13.7	17.1	20.4	21.6	22.4
	21	95	11.2	14.5	18.1	21.6	24.0	24.4	24.3
TGE 40	26	95	10.4	13.8	18.1	23.2	28.3	30.5	32.0
	30	95	11.8	15.6	20.6	26.4	32.1	34.5	36.2
	40	95	14.0	18.6	24.8	32.7	41.2	44.6	46.5
	42	95	22.2	28.4	35.5	42.6	48.1	49.5	49.5

Subcooling correction factor 'fsub'

Subcooling [K]	2	4	10	15	20	25	30
Correction factor	0.98	1.00	1.06	1.12	1.17	1.22	1.27

Subcooling correction factor 'fsub'

Subcooling [°F]	2	7	10	20	30	40	50
Correction factor	0.97	1.00	1.02	1.08	1.14	1.20	1.25

Distributor correction factor 'fp' *

Pressure drop [bar] Δp	Evaporating temperature [°C]						
	-40	-30	-20	-10	0	10	15
0	1	1	1	1	1	1	1
1	0.97	0.96	0.96	0.96	0.95	0.94	0.93
1.5	0.95	0.95	0.94	0.94	0.93	0.91	0.89
2	0.93	0.93	0.92	0.91	0.90	0.87	0.85

*Calculated at 32 °C condensing temperature.

Distributor correction factor 'fp' *

Pressure drop [psi] Δp	Evaporating temperature [°F]						
	-40	-20	0	20	40	50	60
0	1	1	1	1	1	1	1
15	0.96	0.96	0.96	0.95	0.95	0.94	0.93
25	0.94	0.94	0.93	0.92	0.91	0.89	0.87
30	0.93	0.92	0.92	0.91	0.89	0.87	0.84

*Calculated at 90 °F condensing temperature.



Data sheet | Thermostatic expansion valves, type TGE 10, TGE 20, TGE 40

Capacity in kW. -40 – 15 °C.
Opening superheat sh = 4 K

SI units R407F

Valve type	Orifice no.	Cond. temp. [°C]	Evaporating temperature [°C]						
			-40	-30	-20	-10	0	10	15
TGE 10	3	45	4.46	5.63	7.04	8.64	10.3	11.7	12.3
	4	45	5.94	7.52	9.43	11.6	13.8	15.8	16.6
	6	45	8.59	10.9	13.7	16.9	20.2	23.0	24.1
	8	45	11.5	14.6	18.3	22.5	26.8	30.4	31.7
	9	45	13.3	16.9	21.3	26.4	31.5	36.0	37.7
	11	45	16.9	21.9	27.9	34.4	40.3	44.2	45.0
	12.5	45	17.2	22.1	28.0	34.8	41.8	47.9	50.2
TGE 20	12.5	45	17.3	22.3	28.5	35.9	43.9	51.5	54.8
	16	45	21.3	27.4	35.3	44.6	54.8	64.6	68.9
	20	45	26.1	33.6	42.8	53.6	65.2	76.1	80.6
	21	45	37.7	48.1	59.9	72.2	83.2	90.6	92.3
TGE 40	26	45	33.1	43.0	55.6	71.0	88.1	105	112
	30	45	37.4	48.6	62.9	80.3	99.8	119	127
	40	45	44.2	57.3	74.8	97.8	126	157	170
	42	45	76.3	95.9	119	144	167	184	189

Capacity in TR. -40 – 60 °F
Opening superheat sh = 7.2 °F

US units R407F

Valve type	Orifice no.	Cond. temp. [°F]	Evaporating temperature [°F]						
			-40	-20	0	20	40	50	60
TGE 10	3	115	1.26	1.63	2.09	2.60	3.11	3.33	3.50
	4	115	1.67	2.17	2.79	3.49	4.19	4.49	4.73
	6	115	2.41	3.15	4.05	5.08	6.09	6.53	6.88
	8	115	3.22	4.20	5.41	6.77	8.08	8.63	9.06
	9	115	3.72	4.88	6.31	7.93	9.53	10.2	10.8
	11	115	4.75	6.33	8.28	10.3	12.0	12.6	12.8
	12.5	115	4.82	6.36	8.27	10.5	12.6	13.6	14.3
TGE 20	12.5	115	4.87	6.44	8.46	10.9	13.4	14.6	15.6
	16	115	5.96	7.92	10.5	13.5	16.7	18.3	19.6
	20	115	7.31	9.68	12.7	16.2	19.8	21.5	23.0
	21	115	10.6	13.9	17.7	21.6	24.7	25.8	26.4
TGE 40	26	115	9.28	12.4	16.5	21.5	27.0	29.6	32.0
	30	115	10.5	14.0	18.7	24.4	30.5	33.5	36.1
	40	115	12.4	16.5	22.2	30.0	39.5	44.3	48.5
	42	115	21.6	27.8	35.2	43.1	50.0	52.5	54.1

Capacity in kW. -40 – 15 °C.
Opening superheat sh = 4 K

SI units R407F

Valve type	Orifice no.	Cond. temp. [°C]	Evaporating temperature [°C]						
			-40	-30	-20	-10	0	10	15
TGE 10	3	55	4.11	5.23	6.60	8.19	9.91	11.5	12.3
	4	55	5.43	6.92	8.76	10.9	13.2	15.5	16.5
	6	55	7.73	9.89	12.6	15.7	19.1	22.4	23.8
	8	55	10.2	13.1	16.7	20.8	25.3	29.4	31.2
	9	55	11.7	15.1	19.3	24.2	29.6	34.7	36.9
	11	55	15.0	19.7	25.6	32.4	39.0	44.1	45.7
	12.5	55	14.9	19.4	24.9	31.5	38.7	45.7	48.7
TGE 20	12.5	55	15.5	20.0	25.7	32.7	40.5	48.4	52.1
	16	55	18.8	24.4	31.5	40.2	50.1	60.3	65.1
	20	55	23.0	29.8	38.3	48.5	59.9	71.4	76.8
	21	55	34.8	44.9	56.7	69.3	81.1	90.3	93.4
TGE 40	26	55	28.7	37.4	48.7	62.9	79.2	96.4	105
	30	55	32.3	42.1	54.9	71.0	89.5	109	118
	40	55	38.4	49.8	65.0	85.5	113	145	161
	42	55	72.3	91.5	114	140	165	185	193

Capacity in TR. -40 – 60 °F
Opening superheat sh = 7.2 °F

US units R407F

Valve type	Orifice no.	Cond. temp. [°F]	Evaporating temperature [°F]						
			-40	-20	0	20	40	50	60
TGE 10	3	135	1.14	1.49	1.93	2.45	2.99	3.24	3.47
	4	135	1.50	1.97	2.56	3.25	3.99	4.34	4.66
	6	135	2.13	2.80	3.66	4.67	5.75	6.26	6.71
	8	135	2.80	3.70	4.84	6.18	7.57	8.22	8.80
	9	135	3.21	4.27	5.61	7.20	8.90	9.69	10.4
	11	135	4.10	5.57	7.47	9.65	11.6	12.4	13.0
	12.5	135	4.07	5.45	7.22	9.35	11.6	12.7	13.7
TGE 20	12.5	135	4.26	5.66	7.49	9.73	12.2	13.4	14.6
	16	135	5.15	6.88	9.16	12.0	15.1	16.7	18.2
	20	135	6.29	8.40	11.1	14.4	18.0	19.8	21.5
	21	135	9.66	12.8	16.6	20.5	24.1	25.4	26.5
TGE 40	26	135	7.83	10.5	14.1	18.7	23.9	26.6	29.2
	30	135	8.78	11.8	15.9	21.1	27.0	30.1	33.0
	40	135	10.51	14.0	18.9	25.7	34.7	39.9	45.0
	42	135	20.2	26.3	33.6	41.6	49.3	52.4	54.8

Subcooling correction factor 'fsub'

Subcooling [K]	2	4	10	15	20	25	30
Correction factor	0.98	1.00	1.06	1.12	1.17	1.22	1.27

Subcooling correction factor 'fsub'

Subcooling [°F]	2	7	10	20	30	40	50
Correction factor	0.97	1.00	1.02	1.08	1.14	1.20	1.25

Distributer correction factor 'fp' *

Pressure drop [bar] Δp	Evaporating temperature [°C]						
	-40	-30	-20	-10	0	10	15
0	1	1	1	1	1	1	1
1	0.97	0.96	0.96	0.96	0.95	0.94	0.93
1.5	0.95	0.95	0.94	0.94	0.93	0.91	0.89
2	0.93	0.93	0.92	0.91	0.90	0.87	0.85

*Calculated at 32 °C condensing temperature.

Distributer correction factor 'fp' *

Pressure drop [psi] Δp	Evaporating temperature [°F]						
	-40	-20	0	20	40	50	60
0	1	1	1	1	1	1	1
15	0.96	0.96	0.96	0.95	0.95	0.94	0.93
25	0.94	0.94	0.93	0.92	0.91	0.89	0.87
30	0.93	0.92	0.92	0.91	0.89	0.87	0.84

*Calculated at 90 °F condensing temperature.



Data sheet | Thermostatic expansion valves, type TGE 10, TGE 20, TGE 40

Capacity in kW. -40 – 15 °C
Opening superheat sh = 4 K

SI units R407A

Valve type	Orifice no.	Cond. temp. [°C]	Evaporating temperature [°C]						
			-40	-30	-20	-10	0	10	15
TGE 10	3	25	3.89	4.95	6.15	7.35	8.33	8.72	8.52
	4	25	5.26	6.70	8.34	9.99	11.4	11.9	11.6
	6	25	7.77	9.90	12.3	14.8	16.8	17.6	17.2
	8	25	10.5	13.4	16.7	20.0	22.6	23.5	22.9
	9	25	12.6	16.0	19.8	23.8	27.2	28.4	27.5
	11	25	15.6	20.0	24.9	29.4	32.4	32.4	30.9
	12.5	25	16.7	21.3	26.7	32.2	36.8	38.5	37.4
TGE 20	12.5	25	15.8	20.6	26.4	32.8	38.5	41.7	41.3
	16	25	19.6	25.8	33.2	41.3	48.9	53.2	52.9
	20	25	24.2	31.6	40.2	49.4	57.5	61.5	60.5
	21	25	33.0	42.2	52.1	61.3	67.4	67.4	63.7
TGE 40	26	25	31.5	40.9	52.5	65.7	78.6	86.9	86.9
	30	25	35.9	46.6	59.8	74.8	89.4	98.6	98.6
	40	25	43.2	56.2	72.4	91.7	110.9	122	120
	42	25	62.4	78.6	96.8	115	128	131	125

Capacity in TR. -40 – 60 °F
Opening superheat sh = 7.2 °F

US units R407A

Valve type	Orifice no.	Cond. temp. [°F]	Evaporating temperature [°F]						
			-40	-20	0	20	40	50	60
TGE 10	3	75	1.11	1.44	1.82	2.18	2.41	2.43	2.34
	4	75	1.50	1.95	2.47	2.96	3.29	3.32	3.20
	6	75	2.22	2.89	3.66	4.39	4.87	4.91	4.73
	8	75	3.01	3.93	4.95	5.93	6.54	6.56	6.28
	9	75	3.58	4.66	5.89	7.09	7.88	7.92	7.54
	11	75	4.45	5.85	7.37	8.65	9.19	9.02	8.46
	12.5	75	4.76	6.24	7.93	9.60	10.7	10.8	10.3
TGE 20	12.5	75	4.50	6.05	7.92	9.87	11.4	11.7	11.4
	16	75	5.61	7.57	9.95	12.5	14.5	14.9	14.6
	20	75	6.93	9.26	12.0	14.8	16.9	17.2	16.7
	21	75	9.38	12.3	15.4	18.0	19.2	18.8	17.3
TGE 40	26	75	9.01	12.0	15.8	19.9	23.5	24.4	24.0
	30	75	10.3	13.7	18.0	22.7	26.7	27.7	27.3
	40	75	12.4	16.5	21.8	27.9	33.1	34.0	32.8
	42	75	17.7	22.8	28.5	33.8	36.7	36.4	34.0

Capacity in kW. -40 – 15 °C
Opening superheat sh = 4 K

SI units R407A

Valve type	Orifice no.	Cond. temp. [°C]	Evaporating temperature [°C]						
			-40	-30	-20	-10	0	10	15
TGE 10	3	35	3.74	4.81	6.09	7.48	8.81	9.78	10.0
	4	35	5.01	6.47	8.21	10.1	11.9	13.3	13.6
	6	35	7.32	9.46	12.0	14.8	17.5	19.5	20.0
	8	35	9.85	12.7	16.2	19.9	23.5	25.9	26.5
	9	35	11.9	15.3	19.4	23.8	28.1	31.2	31.9
	11	35	14.5	19.1	24.4	29.9	34.4	36.6	36.5
	12.5	35	15.6	20.3	25.8	31.9	37.7	42.0	43.0
TGE 20	12.5	35	14.7	19.3	25.2	32.0	39.1	45.0	46.8
	16	35	18.1	24.0	31.3	40.0	49.1	56.9	59.5
	20	35	22.3	29.4	38.0	48.0	58.2	66.5	68.9
	21	35	32.3	41.8	52.4	63.1	71.8	76.3	76.2
TGE 40	26	35	29.4	38.4	49.9	63.6	78.3	91.4	96.2
	30	35	33.3	43.6	56.7	72.2	88.9	104	109
	40	35	39.7	52.0	68.0	88.3	112	133	139
	42	35	62.0	78.8	98.4	119	138	149	150

Capacity in TR. -40 – 60 °F
Opening superheat sh = 7.2 °F

US units R407A

Valve type	Orifice no.	Cond. temp. [°F]	Evaporating temperature [°F]						
			-40	-20	0	20	40	50	60
TGE 10	3	95	1.06	1.40	1.82	2.26	2.64	2.78	2.85
	4	95	1.42	1.89	2.45	3.05	3.58	3.77	3.88
	6	95	2.08	2.76	3.58	4.48	5.27	5.54	5.68
	8	95	2.80	3.72	4.82	6.00	7.03	7.36	7.52
	9	95	3.38	4.47	5.77	7.18	8.43	8.86	9.08
	11	95	4.13	5.57	7.27	8.96	10.2	10.4	10.3
	12.5	95	4.44	5.91	7.70	9.63	11.3	11.9	12.2
TGE 20	12.5	95	4.17	5.66	7.56	9.77	11.9	12.8	13.3
	16	95	5.15	7.01	9.41	12.2	15.0	16.2	16.9
	20	95	6.34	8.58	11.4	14.6	17.7	18.9	19.6
	21	95	9.17	12.2	15.6	18.8	21.1	21.7	21.6
TGE 40	26	95	8.34	11.2	15.0	19.4	24.0	26.0	27.5
	30	95	9.46	12.8	17.0	22.1	27.2	29.4	31.1
	40	95	11.3	15.2	20.5	27.2	34.7	37.8	39.7
	42	95	17.6	23.0	29.2	35.7	40.8	42.3	42.7

Subcooling correction factor 'fsub'

Subcooling [K]	2	4	10	15	20	25	30
Correction factor	0.98	1.00	1.07	1.12	1.18	1.24	1.29

Distributer correction factor 'fp' *

Pressure drop [bar] Δp	Evaporating temperature [°C]						
	-40	-30	-20	-10	0	10	15
0	1	1	1	1	1	1	1
1	0.96	0.96	0.96	0.96	0.95	0.94	0.92
1.5	0.95	0.94	0.94	0.93	0.92	0.90	0.88
2	0.93	0.92	0.92	0.91	0.89	0.87	0.84

*Calculated at 32 °C condensing temperature.

Subcooling correction factor 'fsub'

Subcooling [°F]	2	7	10	20	30	40	50
Correction factor	0.97	1.00	1.02	1.08	1.15	1.21	1.27

Distributer correction factor 'fp' *

Pressure drop [psi] Δp	Evaporating temperature [°F]						
	-40	-20	0	20	40	50	60
0	1	1	1	1	1	1	1
15	0.96	0.96	0.96	0.95	0.94	0.93	0.92
25	0.94	0.93	0.93	0.92	0.90	0.89	0.86
30	0.92	0.92	0.91	0.90	0.88	0.86	0.83

*Calculated at 90 °F condensing temperature.



Data sheet | Thermostatic expansion valves, type TGE 10, TGE 20, TGE 40

Capacity in kW. -40 – 15 °C
Opening superheat sh = 4 K

SI units R407A

Valve type	Orifice no.	Cond. temp. [°C]	Evaporating temperature [°C]						
			-40	-30	-20	-10	0	10	15
TGE 10	3	45	3.45	4.49	5.76	7.22	8.73	10.1	10.6
	4	45	4.59	5.99	7.70	9.68	11.8	13.6	14.3
	6	45	6.63	8.66	11.2	14.1	17.1	19.8	20.9
	8	45	8.83	11.5	14.9	18.8	22.8	26.2	27.5
	9	45	10.9	14.1	18.1	22.8	27.5	31.7	33.3
	11	45	13.0	17.3	22.7	28.7	34.3	38.1	39.0
	12.5	45	14.0	18.5	23.9	30.1	36.6	42.3	44.5
TGE 20	12.5	45	13.2	17.4	22.8	29.5	37.0	44.3	47.4
	16	45	16.1	21.4	28.2	36.6	46.1	55.5	59.6
	20	45	19.8	26.2	34.2	44.0	54.9	65.4	69.8
	21	45	30.5	39.9	50.9	62.3	72.5	79.7	81.7
TGE 40	26	45	26.4	34.7	45.5	58.7	73.8	88.9	95.8
	30	45	29.8	39.2	51.5	66.6	83.6	101	108
	40	45	35.3	46.5	61.2	80.6	105	132	144
	42	45	59.7	76.6	96.6	119	140	157	162

Capacity in TR. -40 – 60 °F
Opening superheat sh = 7.2 °F

US units R407A

Valve type	Orifice no.	Cond. temp. [°F]	Evaporating temperature [°F]						
			-40	-20	0	20	40	50	60
TGE 10	3	115	0.97	1.30	1.71	2.18	2.65	2.86	3.03
	4	115	1.29	1.73	2.28	2.92	3.57	3.86	4.09
	6	115	1.86	2.50	3.31	4.25	5.20	5.61	5.95
	8	115	2.47	3.33	4.41	5.66	6.90	7.42	7.83
	9	115	3.04	4.08	5.37	6.85	8.33	8.97	9.50
	11	115	3.62	5.00	6.73	8.64	10.3	11.0	11.1
	12.5	115	3.93	5.33	7.08	9.10	11.1	12.0	12.7
TGE 20	12.5	115	3.69	5.02	6.79	8.97	11.4	12.5	13.5
	16	115	4.51	6.16	8.37	11.1	14.2	15.6	16.9
	20	115	5.54	7.54	10.1	13.3	16.8	18.4	19.9
	21	115	8.59	11.6	15.1	18.7	21.6	22.7	23.3
TGE 40	26	115	7.37	10.0	13.5	17.9	22.7	25.0	27.3
	30	115	8.32	11.3	15.3	20.2	25.7	28.4	30.8
	40	115	9.88	13.4	18.2	24.7	32.9	37.2	41.0
	42	115	16.9	22.2	28.7	35.7	42.0	44.5	46.3

Capacity in kW. -40 – 15 °C
Opening superheat sh = 4 K

SI units R407A

Valve type	Orifice no.	Cond. temp. [°C]	Evaporating temperature [°C]						
			-40	-30	-20	-10	0	10	15
TGE 10	3	55	3.07	4.01	5.20	6.61	8.16	9.67	10.3
	4	55	4.04	5.30	6.89	8.80	10.9	13.0	14.0
	6	55	5.74	7.56	9.87	12.6	15.7	18.7	20.1
	8	55	7.56	9.98	13.0	16.7	20.8	24.7	26.3
	9	55	9.41	12.4	16.2	20.6	25.5	30.2	32.3
	11	55	11.0	14.9	20.0	26.0	32.1	37.0	38.6
	12.5	55	12.0	16.0	21.0	27.0	33.6	40.0	42.9
TGE 20	12.5	55	11.4	15.0	19.8	25.8	32.9	40.4	44.0
	16	55	13.8	18.2	24.2	31.7	40.7	50.2	54.8
	20	55	16.9	22.3	29.4	38.1	48.5	59.5	64.7
	21	55	27.7	36.7	47.4	58.9	69.9	78.7	81.8
TGE 40	26	55	22.5	29.8	39.4	51.5	65.7	80.9	88.5
	30	55	25.3	33.6	44.5	58.2	74.3	91.5	100
	40	55	30.3	39.9	52.7	69.9	92.6	120	134
	42	55	55.6	71.9	91.6	114	136	156	163

Capacity in TR. -40 – 60 °F
Opening superheat sh = 7.2 °F

US units R407A

Valve type	Orifice no.	Cond. temp. [°F]	Evaporating temperature [°F]						
			-40	-20	0	20	40	50	60
TGE 10	3	135	0.84	1.14	1.51	1.97	2.46	2.70	2.91
	4	135	1.11	1.50	2.01	2.62	3.28	3.61	3.90
	6	135	1.57	2.13	2.86	3.76	4.73	5.20	5.62
	8	135	2.06	2.81	3.78	4.96	6.23	6.83	7.37
	9	135	2.56	3.50	4.70	6.13	7.67	8.40	9.08
	11	135	2.99	4.21	5.82	7.73	9.58	10.3	10.9
	12.5	135	3.24	4.48	6.09	8.03	10.1	11.1	12.0
TGE 20	12.5	135	3.11	4.22	5.74	7.69	9.97	11.1	12.3
	16	135	3.76	5.12	7.00	9.44	12.3	13.8	15.3
	20	135	4.60	6.27	8.48	11.3	14.6	16.4	18.0
	21	135	7.64	10.5	13.9	17.5	20.8	22.1	23.1
TGE 40	26	135	6.12	8.4	11.4	15.3	19.9	22.3	24.7
	30	135	6.86	9.4	12.9	17.3	22.5	25.2	27.9
	40	135	8.24	11.2	15.3	21.0	28.6	33.0	37.5
	42	135	15.4	20.6	26.9	34.0	40.9	43.8	46.3

Subcooling correction factor 'fsub'

Subcooling [K]	2	4	10	15	20	25	30
Correction factor	0.98	1.00	1.07	1.12	1.18	1.24	1.29

Distributer correction factor 'fp' *

Pressure drop [bar] Δp	Evaporating temperature [°C]						
	-40	-30	-20	-10	0	10	15
	Correction factor						
0	1	1	1	1	1	1	1
1	0.96	0.96	0.96	0.96	0.95	0.94	0.92
1.5	0.95	0.94	0.94	0.93	0.92	0.90	0.88
2	0.93	0.92	0.92	0.91	0.89	0.87	0.84

*Calculated at 32 °C condensing temperature.

Subcooling correction factor 'fsub'

Subcooling [°F]	2	7	10	20	30	40	50
Correction factor	0.97	1.00	1.02	1.08	1.15	1.21	1.27

Distributer correction factor 'fp' *

Pressure drop [psi] Δp	Evaporating temperature [°F]						
	-40	-20	0	20	40	50	60
	Correction factor						
0	1	1	1	1	1	1	1
15	0.96	0.96	0.96	0.95	0.94	0.93	0.92
25	0.94	0.93	0.93	0.92	0.90	0.89	0.86
30	0.92	0.92	0.91	0.90	0.88	0.86	0.83

*Calculated at 90 °F condensing temperature.



Data sheet | Thermostatic expansion valves, type TGE 10, TGE 20, TGE 40

Capacity in kW. -40 – 15 °C
Opening superheat sh = 4 K

SI units R404A/R507

Valve type	Orifice no.	Cond. temp. [°C]	Evaporating temperature [°C]						
			-40	-30	-20	-10	0	10	15
TGE 10	3	25	3.13	4.03	5.00	5.92	6.53	6.41	5.88
	4	25	4.24	5.47	6.80	8.06	8.92	8.77	8.04
	6	25	6.27	8.10	10.1	12.0	13.2	13.0	11.9
	8	25	8.54	11.0	13.7	16.2	17.8	17.3	15.8
	9	25	10.0	12.9	16.0	19.0	21.0	20.8	19.0
	11	25	12.7	16.4	20.2	23.5	25.1	23.5	21.0
	12.5	25	13.4	17.3	21.7	25.8	28.5	28.3	25.9
TGE 20	16	25	15.7	20.2	25.2	29.8	33.0	32.6	29.8
	12.5	25	12.9	17.1	21.9	26.8	30.5	30.8	28.6
	16	25	16.2	21.5	27.6	33.9	38.9	39.5	36.7
	20	25	19.9	26.1	33.2	40.3	45.5	45.12	41.5
TGE 40	21	25	26.2	33.6	41.2	47.6	50.7	47.8	42.6
	26	25	26.3	34.8	44.8	55.3	64.0	66.7	62.9
	30	25	30.0	39.6	51.0	63.0	72.8	75.7	71.3
	40	25	36.0	47.8	62.1	77.7	90.4	91.8	84.4
	42	25	51.0	65.0	79.9	93.2	101	95.9	85.7

Capacity in TR. -40 – 60 °F
Opening superheat sh = 7.2 °F

US units R404A/R507

Valve type	Orifice no.	Cond. temp. [°F]	Evaporating temperature [°F]						
			-40	-20	0	20	40	50	60
TGE 10	3	75	0.89	1.18	1.48	1.74	1.84	1.77	1.57
	4	75	1.21	1.60	2.01	2.37	2.52	2.42	2.15
	6	75	1.79	2.37	2.99	3.53	3.74	3.59	3.18
	8	75	2.44	3.22	4.05	4.76	5.00	4.79	4.21
	9	75	2.87	3.77	4.75	5.60	5.96	5.75	5.05
	11	75	3.63	4.79	5.96	6.84	6.93	6.49	5.58
	12.5	75	3.84	5.08	6.43	7.61	8.11	7.84	6.91
TGE 20	16	75	4.50	5.93	7.47	8.81	9.36	9.02	7.92
	12.5	75	3.70	5.03	6.55	7.99	8.74	8.53	7.65
	16	75	4.63	6.32	8.26	10.2	11.2	11.0	9.85
	20	75	5.69	7.69	9.92	12.0	13.0	12.5	11.1
TGE 40	21	75	7.47	9.79	12.1	13.8	14.1	13.2	11.3
	26	75	7.54	10.2	13.4	16.6	18.7	18.6	16.9
	30	75	8.59	11.7	15.3	18.9	21.2	21.1	19.2
	40	75	10.3	14.1	18.7	23.4	26.1	25.4	22.5
	42	75	14.5	19.0	23.5	27.2	28.0	26.42	22.6

Capacity in kW. -40 – 15 °C
Opening superheat sh = 4 K

SI units R404A/R507

Valve type	Orifice no.	Cond. temp. [°C]	Evaporating temperature [°C]						
			-40	-30	-20	-10	0	10	15
TGE 10	3	35	2.91	3.83	4.87	5.98	6.97	7.52	7.50
	4	35	3.92	5.16	6.58	8.10	9.47	10.2	10.2
	6	35	5.74	7.57	9.67	11.9	13.9	15.1	15.0
	8	35	7.75	10.2	13.0	16.0	18.6	20.0	19.8
	9	35	9.23	12.1	15.3	18.7	21.7	23.4	23.5
	11	35	11.6	15.3	19.5	23.6	26.9	27.8	26.9
	12.5	35	12.2	16.1	20.6	25.2	29.3	31.6	31.7
TGE 20	16	35	14.3	18.9	24.0	29.4	34.0	36.7	36.8
	12.5	35	11.7	15.7	20.5	26.0	31.4	35.0	35.3
	16	35	14.5	19.5	25.7	32.7	39.6	44.4	45.0
	20	35	17.8	23.8	31.0	39.0	46.7	51.5	51.6
TGE 40	21	35	24.7	32.3	40.5	48.2	53.9	55.6	54.5
	26	35	23.7	31.8	41.7	52.9	63.8	72.0	74.1
	30	35	27.0	36.1	47.4	60.1	72.4	81.6	83.8
	40	35	31.9	43.0	57.1	74.3	92.2	104	105
	42	35	48.5	63.0	79.1	95.0	107	112	111

Capacity in TR. -40 – 60 °F
Opening superheat sh = 7.2 °F

US units R404A/R507

Valve type	Orifice no.	Cond. temp. [°F]	Evaporating temperature [°F]						
			-40	-20	0	20	40	50	60
TGE 10	3	95	0.83	1.12	1.45	1.80	2.07	2.14	2.12
	4	95	1.11	1.51	1.96	2.44	2.82	2.91	2.89
	6	95	1.63	2.21	2.89	3.59	4.14	4.28	4.25
	8	95	2.20	2.98	3.88	4.81	5.52	5.67	5.61
	9	95	2.62	3.52	4.57	5.62	6.43	6.64	6.65
	11	95	3.28	4.47	5.80	7.06	7.84	7.88	7.60
	12.5	95	3.47	4.70	6.14	7.58	8.68	8.97	8.98
TGE 20	16	95	4.07	5.50	7.15	8.81	10.1	10.4	10.4
	12.5	95	3.31	4.59	6.16	7.92	9.46	9.92	10.0
	16	95	4.11	5.72	7.70	9.95	12.0	12.6	12.8
	20	95	5.05	6.97	9.28	11.8	14.0	14.6	14.6
TGE 40	21	95	7.01	9.41	12.0	14.3	15.7	15.8	15.4
	26	95	6.73	9.30	12.5	16.1	19.3	20.4	21.1
	30	95	7.65	10.6	14.2	18.3	21.9	23.2	23.8
	40	95	9.05	12.6	17.2	22.8	28.1	29.6	29.9
	42	95	13.8	18.4	23.5	28.3	31.4	31.9	31.3

Subcooling correction factor 'fsub'

Subcooling [K]	2	4	10	15	20	25	30
Correction factor	0.97	1.00	1.08	1.15	1.22	1.29	1.36

Distributer correction factor 'fp' *

Pressure drop [bar] Δp	Evaporating temperature [°C]						
	-40	-30	-20	-10	0	10	15
0	1	1	1	1	1	1	1
1	0.96	0.96	0.96	0.95	0.94	0.92	0.91
1.5	0.94	0.94	0.94	0.93	0.91	0.88	0.86
2	0.92	0.92	0.91	0.90	0.88	0.84	0.80

*Calculated at 32 °C condensing temperature.

Subcooling correction factor 'fsub'

Subcooling [°F]	2	7	10	20	30	40	50
Correction factor	0.96	1.00	1.02	1.10	1.18	1.25	1.33

Distributer correction factor 'fp' *

Pressure drop [psi] Δp	Evaporating temperature [°F]						
	-40	-20	0	20	40	50	60
0	1	1	1	1	1	1	1
15	0.96	0.96	0.96	0.95	0.93	0.92	0.90
25	0.94	0.93	0.92	0.91	0.89	0.87	0.83
30	0.92	0.92	0.91	0.89	0.86	0.84	0.79

*Calculated at 90 °F condensing temperature.



Data sheet | Thermostatic expansion valves, type TGE 10, TGE 20, TGE 40

Capacity in kW. -40 – 15 °C
Opening superheat sh = 4 K

SI units R404A/R507

Valve type	Orifice no.	Cond. temp. [°C]	Evaporating temperature [°C]						
			-40	-30	-20	-10	0	10	15
TGE 10	3	45	2.57	3.44	4.47	5.64	6.83	7.81	8.10
	4	45	3.43	4.61	6.00	7.58	9.22	10.6	11.0
	6	45	4.98	6.70	8.74	11.1	13.5	15.4	16.0
	8	45	6.67	8.97	11.7	14.8	17.9	20.4	21.1
	9	45	8.01	10.7	13.9	17.4	20.8	23.6	24.5
	11	45	9.94	13.5	17.7	22.2	26.4	29.1	29.4
	12.5	45	10.5	14.1	18.5	23.3	27.9	31.6	32.8
TGE 20	12.5	45	10.0	13.6	18.1	23.5	29.4	34.7	36.6
	16	45	12.3	16.8	22.4	29.2	36.8	43.8	46.3
	20	45	15.1	20.6	27.2	35.0	43.7	51.4	54.0
	21	45	22.1	29.4	37.7	46.0	53.1	57.5	58.4
TGE 40	26	45	20.2	27.5	36.6	47.5	58.9	69.4	73.9
	30	45	22.9	31.1	41.6	53.9	66.8	78.6	83.5
	40	45	26.8	36.5	49.4	65.9	85.5	104	110
	42	45	44.0	58.0	74.1	91.1	106	117	119

Capacity in TR. -40 – 60 °F
Opening superheat sh = 7.2 °F

US units R404A/R507

Valve type	Orifice no.	Cond. temp. [°F]	Evaporating temperature [°F]						
			-40	-20	0	20	40	50	60
TGE 10	3	115	0.72	0.99	1.32	1.70	2.06	2.21	2.31
	4	115	0.96	1.33	1.77	2.28	2.78	2.99	3.12
	6	115	1.39	1.93	2.58	3.33	4.06	4.36	4.55
	8	115	1.85	2.58	3.45	4.43	5.39	5.76	5.99
	9	115	2.23	3.06	4.09	5.20	6.24	6.65	6.95
	11	115	2.76	3.89	5.23	6.65	7.87	8.23	8.34
	12.5	115	2.91	4.05	5.45	6.97	8.37	8.92	9.33
TGE 20	12.5	115	2.78	3.91	5.36	7.10	8.96	9.78	10.4
	16	115	3.42	4.84	6.64	8.85	11.2	12.3	13.1
	20	115	4.20	5.90	8.02	10.6	13.3	14.5	15.3
	21	115	6.16	8.47	11.1	13.7	15.7	16.3	16.6
TGE 40	26	115	5.60	7.89	10.8	14.3	17.9	19.5	21.0
	30	115	6.34	8.94	12.3	16.3	20.3	22.1	23.7
	40	115	7.42	10.5	14.7	20.1	26.5	29.3	31.4
	42	115	12.3	16.7	21.9	27.2	31.6	33.1	34.0

Capacity in kW. -40 – 15 °C
Opening superheat sh = 4 K

SI units R404A/R507

Valve type	Orifice no.	Cond. temp. [°C]	Evaporating temperature [°C]						
			-40	-30	-20	-10	0	10	15
TGE 10	3	55	2.13	2.91	3.83	4.92	6.11	7.25	7.72
	4	55	2.82	3.86	5.11	6.57	8.19	9.75	10.4
	6	55	4.04	5.55	7.36	9.49	11.9	14.1	15.0
	8	55	5.36	7.37	9.77	12.6	15.7	18.6	19.8
	9	55	6.39	8.72	11.6	14.9	18.4	21.6	23.0
	11	55	7.95	11.2	15.0	19.3	23.7	27.3	28.4
	12.5	55	8.25	11.4	15.3	19.8	24.5	28.8	30.7
TGE 20	12.5	55	8.07	11.1	14.9	19.6	25.0	30.7	33.3
	16	55	9.86	13.6	18.3	24.2	31.1	38.4	41.7
	20	55	12.1	16.7	22.2	29.1	37.1	45.6	49.3
	21	55	18.3	25.0	32.8	41.0	48.5	54.3	56.3
TGE 40	26	55	15.8	21.9	29.7	39.3	50.1	61.0	66.2
	30	55	17.8	24.7	33.6	44.5	56.7	69.0	74.9
	40	55	21.0	29.0	39.6	53.8	72.0	92.2	101
	42	55	37.1	49.9	65.2	81.9	98.0	111	116

Capacity in TR. -40 – 60 °F
Opening superheat sh = 7.2 °F

US units R404A/R507

Valve type	Orifice no.	Cond. temp. [°F]	Evaporating temperature [°F]						
			-40	-20	0	20	40	50	60
TGE 10	3	135	0.57	0.81	1.10	1.44	1.81	1.99	2.14
	4	135	0.76	1.08	1.47	1.93	2.43	2.67	2.87
	6	135	1.08	1.54	2.11	2.78	3.51	3.86	4.15
	8	135	1.43	2.04	2.79	3.68	4.63	5.08	5.45
	9	135	1.69	2.40	3.31	4.36	5.43	5.93	6.38
	11	135	2.12	3.10	4.29	5.65	6.99	7.52	7.87
	12.5	135	2.18	3.13	4.36	5.78	7.23	7.89	8.49
TGE 20	12.5	135	2.16	3.08	4.25	5.73	7.45	8.33	9.13
	16	135	2.63	3.77	5.23	7.08	9.27	10.4	11.4
	20	135	3.22	4.61	6.34	8.50	11.0	12.4	13.5
	21	135	4.91	6.96	9.40	12.0	14.2	15.0	15.7
TGE 40	26	135	4.16	6.00	8.46	11.5	14.8	16.5	18.2
	30	135	4.68	6.77	9.56	13.0	16.8	18.7	20.6
	40	135	5.57	7.99	11.3	15.9	21.8	25.0	27.9
	42	135	10.0	14.0	18.8	24.0	28.8	30.8	32.4

Subcooling correction factor 'fsub'

Subcooling [K]	2	4	10	15	20	25	30
Correction factor	0.97	1.00	1.08	1.15	1.22	1.29	1.36

Subcooling correction factor 'fsub'

Subcooling [°F]	2	7	10	20	30	40	50
Correction factor	0.96	1.00	1.02	1.10	1.18	1.25	1.33

Distributer correction factor 'fp'*

Pressure drop [bar] Δp	Evaporating temperature [°C]						
	-40	-30	-20	-10	0	10	15
	Correction factor						
0	1	1	1	1	1	1	1
1	0.96	0.96	0.96	0.95	0.94	0.92	0.91
1.5	0.94	0.94	0.94	0.93	0.91	0.88	0.86
2	0.92	0.92	0.91	0.90	0.88	0.84	0.80

*Calculated at 32 °C condensing temperature.

Distributer correction factor 'fp'*

Pressure drop [psi] Δp	Evaporating temperature [°F]						
	-40	-20	0	20	40	50	60
	Correction factor						
0	1	1	1	1	1	1	1
15	0.96	0.96	0.96	0.95	0.93	0.92	0.90
25	0.94	0.93	0.92	0.91	0.89	0.87	0.83
30	0.92	0.92	0.91	0.89	0.86	0.84	0.79

*Calculated at 90 °F condensing temperature.



Data sheet | Thermostatic expansion valves, type TGE 10, TGE 20, TGE 40

Capacity in kW. -40 – 15 °C.
Opening superheat sh = 4 K

SI units R407C

Valve type	Orifice no.	Cond. temp. [°C]	Evaporating temperature [°C]						
			-40	-30	-20	-10	0	10	15
TGE 10	3	25	4.13	5.24	6.49	7.76	8.80	9.24	9.07
	4	25	5.58	7.09	8.80	10.6	12.0	12.6	12.4
	6	25	8.23	10.5	13.0	15.6	17.8	18.7	18.3
	8	25	11.2	14.2	17.6	21.1	23.9	24.9	24.3
	9	25	13.3	16.9	21.0	25.2	28.7	30.1	29.3
	11	25	16.5	21.2	26.3	31.1	34.2	34.4	32.9
	12.5	25	17.7	22.6	28.2	34.0	38.9	40.9	39.8
TGE 20	12.5	25	16.7	21.8	27.9	34.6	40.7	44.2	44.0
	16	25	20.8	27.2	35.0	43.6	51.6	56.4	56.3
	20	25	25.7	33.4	42.5	52.2	60.8	65.2	64.4
	21	25	35.0	44.6	55.0	64.7	71.3	71.5	67.9
TGE 40	26	25	33.4	43.3	55.4	69.4	83.0	92.1	92.6
	30	25	38.1	49.3	63.1	79.0	94.4	105	105
	40	25	45.8	59.4	76.5	96.8	117	129	127
	42	25	66.1	83.1	102	121	136	139	133

Capacity in TR. -40 – 60 °F
Opening superheat sh = 7.2 °F

US units R407C

Valve type	Orifice no.	Cond. temp. [°F]	Evaporating temperature [°F]						
			-40	-20	0	20	40	50	60
TGE 10	3	75	1.17	1.52	1.92	2.30	2.55	2.57	2.49
	4	75	1.59	2.07	2.61	3.13	3.48	3.52	3.41
	6	75	2.35	3.05	3.86	4.63	5.15	5.21	5.04
	8	75	3.19	4.15	5.23	6.26	6.91	6.95	6.70
	9	75	3.79	4.92	6.21	7.48	8.34	8.40	8.04
	11	75	4.72	6.18	7.77	9.13	9.72	9.57	9.02
	12.5	75	5.04	6.59	8.37	10.1	11.3	11.4	10.9
TGE 20	12.5	75	4.76	6.39	8.35	10.4	12.0	12.4	12.2
	16	75	5.94	8.00	10.5	13.2	15.3	15.8	15.6
	20	75	7.33	9.79	12.7	15.7	17.9	18.2	17.8
	21	75	9.93	13.0	16.2	19.0	20.3	19.9	18.5
TGE 40	26	75	9.54	12.7	16.6	21.0	24.8	25.8	25.6
	30	75	10.9	14.5	18.9	23.9	28.2	29.3	29.1
	40	75	13.1	17.5	23.0	29.5	35.0	36.0	34.9
	42	75	18.7	24.1	30.1	35.7	38.8	38.6	36.2

Capacity in kW. -40 – 15 °C.
Opening superheat sh = 4 K

SI units R407C

Valve type	Orifice no.	Cond. temp. [°C]	Evaporating temperature [°C]						
			-40	-30	-20	-10	0	10	15
TGE 10	3	35	4.00	5.14	6.49	7.96	9.36	10.4	10.7
	4	35	5.37	6.91	8.74	10.8	12.7	14.1	14.5
	6	35	7.84	10.1	12.8	15.8	18.6	20.8	21.3
	8	35	10.5	13.6	17.2	21.2	24.9	27.6	28.2
	9	35	12.7	16.3	20.6	25.3	29.8	33.2	34.0
	11	35	15.6	20.3	26.0	31.8	36.6	38.9	38.9
	12.5	35	16.7	21.6	27.5	33.9	40.1	44.7	45.8
TGE 20	12.5	35	15.7	20.6	26.8	34.0	41.5	47.8	49.9
	16	35	19.4	25.6	33.4	42.5	52.2	60.5	63.3
	20	35	23.9	31.3	40.5	51.0	61.9	70.7	73.3
	21	35	34.6	44.6	55.8	67.1	76.3	81.2	81.2
TGE 40	26	35	31.5	41.0	53.1	67.6	83.2	97.2	103
	30	35	35.7	46.5	60.3	76.8	94.4	110	116
	40	35	42.5	55.6	72.5	93.9	119	142	148
	42	35	66.3	84.1	105	127	146	158	160

Capacity in TR. -40 – 60 °F
Opening superheat sh = 7.2 °F

US units R407C

Valve type	Orifice no.	Cond. temp. [°F]	Evaporating temperature [°F]						
			-40	-20	0	20	40	50	60
TGE 10	3	95	1.14	1.50	1.93	2.40	2.81	2.95	3.04
	4	95	1.52	2.02	2.61	3.24	3.81	4.01	4.13
	6	95	2.23	2.95	3.82	4.76	5.60	5.90	6.06
	8	95	2.99	3.97	5.13	6.38	7.47	7.83	8.01
	9	95	3.62	4.77	6.15	7.64	8.96	9.43	9.67
	11	95	4.42	5.94	7.74	9.53	10.8	11.1	11.0
	12.5	95	4.75	6.31	8.20	10.2	12.1	12.7	13.0
TGE 20	12.5	95	4.46	6.04	8.05	10.4	12.7	13.6	14.2
	16	95	5.51	7.48	10.0	13.0	16.0	17.2	18.1
	20	95	6.79	9.16	12.1	15.5	18.8	20.1	20.9
	21	95	9.81	13.0	16.6	20.0	22.5	23.1	23.0
TGE 40	26	95	8.93	12.0	16.0	20.7	25.5	27.6	29.2
	30	95	10.1	13.6	18.1	23.5	28.9	31.3	33.1
	40	95	12.1	16.3	21.8	29.0	36.8	40.2	42.3
	42	95	18.8	24.5	31.1	37.9	43.4	45.0	45.4

Subcooling correction factor 'fsub'

Subcooling [K]	2	4	10	15	20	25	30
Correction factor	0.98	1.00	1.06	1.12	1.17	1.22	1.27

Subcooling correction factor 'fsub'

Subcooling [°F]	2	7	10	20	30	40	50
Correction factor	0.97	1.00	1.02	1.08	1.14	1.19	1.25

Distributor correction factor 'fp' *

Pressure drop [bar] Δp	Evaporating temperature [°C]						
	-40	-30	-20	-10	0	10	15
0	1	1	1	1	1	1	1
1	0.96	0.96	0.96	0.95	0.95	0.93	0.92
1.5	0.94	0.94	0.94	0.93	0.92	0.90	0.88
2	0.92	0.92	0.91	0.91	0.89	0.86	0.84

*Calculated at 32 °C condensing temperature.

Distributor correction factor 'fp' *

Pressure drop [psi] Δp	Evaporating temperature [°F]						
	-40	-20	0	20	40	50	60
0	1	1	1	1	1	1	1
15	0.96	0.96	0.96	0.95	0.94	0.93	0.92
25	0.93	0.93	0.93	0.92	0.90	0.88	0.86
30	0.92	0.92	0.91	0.90	0.88	0.86	0.83

*Calculated at 90 °C condensing temperature.



Data sheet | Thermostatic expansion valves, type TGE 10, TGE 20, TGE 40

Capacity in kW. -40 – 15 °C.
Opening superheat sh = 4 K

SI units R407C

Valve type	Orifice no.	Cond. temp. [°C]	Evaporating temperature [°C]						
			-40	-30	-20	-10	0	10	15
TGE 10	3	45	3.75	4.85	6.20	7.75	9.36	10.8	11.4
	4	45	4.98	6.47	8.29	10.4	12.6	14.6	15.4
	6	45	7.19	9.35	12.0	15.1	18.4	21.3	22.4
	8	45	9.57	12.5	16.0	20.2	24.4	28.1	29.5
	9	45	11.8	15.3	19.5	24.4	29.5	33.9	35.7
	11	45	14.1	18.7	24.4	30.8	36.8	40.8	41.8
	12.5	45	15.2	19.9	25.7	32.4	39.3	45.4	47.7
TGE 20	12.5	45	14.3	18.8	24.6	31.7	39.7	47.4	50.8
	16	45	17.5	23.1	30.3	39.3	49.4	59.5	63.8
	20	45	21.5	28.3	36.8	47.2	58.9	70.1	74.8
	21	45	33.1	43.2	54.8	66.9	77.8	85.4	87.6
TGE 40	26	45	28.6	37.5	49.0	63.1	79.1	95.2	103
	30	45	32.3	42.4	55.4	71.5	89.6	108	116
	40	45	38.3	50.2	65.9	86.6	113	141	154
	42	45	64.8	82.7	104	127	150	168	174

Capacity in TR. -40 – 60 °F
Opening superheat sh = 7.2 °F

US units R407C

Valve type	Orifice no.	Cond. temp. [°F]	Evaporating temperature [°F]						
			-40	-20	0	20	40	50	60
TGE 10	3	115	1.05	1.40	1.84	2.34	2.84	3.07	3.25
	4	115	1.40	1.87	2.46	3.14	3.83	4.14	4.39
	6	115	2.02	2.70	3.56	4.56	5.58	6.02	6.38
	8	115	2.68	3.60	4.75	6.08	7.40	7.96	8.40
	9	115	3.30	4.41	5.79	7.37	8.94	9.63	10.2
	11	115	3.94	5.41	7.26	9.29	11.0	11.6	11.9
	12.5	115	4.27	5.76	7.63	9.78	11.9	12.9	13.6
TGE 20	12.5	115	4.01	5.43	7.31	9.64	12.2	13.4	14.5
	16	115	4.90	6.66	9.02	12.0	15.2	16.8	18.2
	20	115	6.02	8.15	10.9	14.3	18.0	19.8	21.3
	21	115	9.33	12.5	16.3	20.0	23.2	24.3	25.0
TGE 40	26	115	8.01	10.8	14.6	19.2	24.3	26.9	29.2
	30	115	9.04	12.2	16.5	21.7	27.6	30.4	33.1
	40	115	10.7	14.5	19.6	26.6	35.3	39.9	44.0
	42	115	18.3	24.0	30.9	38.3	45.1	47.8	49.6

Capacity in kW. -40 – 15 °C.
Opening superheat sh = 4 K

SI units R407C

Valve type	Orifice no.	Cond. temp. [°C]	Evaporating temperature [°C]						
			-40	-30	-20	-10	0	10	15
TGE 10	3	55	3.39	4.41	5.68	7.20	8.86	10.5	11.2
	4	55	4.46	5.82	7.54	9.59	11.8	14.1	15.0
	6	55	6.35	8.31	10.8	13.8	17.1	20.3	21.7
	8	55	8.36	11.0	14.3	18.2	22.6	26.7	28.5
	9	55	10.4	13.6	17.7	22.5	27.7	32.7	35.0
	11	55	12.2	16.4	21.9	28.3	34.8	40.1	41.8
	12.5	55	13.2	17.5	23.0	29.5	36.5	43.4	46.4
TGE 20	12.5	55	12.6	16.5	21.6	28.1	35.8	43.8	47.7
	16	55	15.3	20.0	26.4	34.5	44.2	54.4	59.4
	20	55	18.7	24.5	32.1	41.5	52.6	64.4	70.0
	21	55	30.6	40.3	51.8	64.2	75.9	85.3	88.7
TGE 40	26	55	24.9	32.8	43.1	56.1	71.3	87.7	95.8
	30	55	28.0	36.9	48.6	63.4	80.7	99.1	108
	40	55	33.5	43.8	57.6	76.1	101	130	145
	42	55	61.5	79.0	100	124	148	169	177

Capacity in TR. -40 – 60 °F
Opening superheat sh = 7.2 °F

US units R407C

Valve type	Orifice no.	Cond. temp. [°F]	Evaporating temperature [°F]						
			-40	-20	0	20	40	50	60
TGE 10	3	135	0.94	1.25	1.66	2.15	2.68	2.93	3.16
	4	135	1.23	1.65	2.20	2.86	3.58	3.92	4.24
	6	135	1.74	2.35	3.14	4.10	5.15	5.66	6.11
	8	135	2.29	3.10	4.15	5.42	6.78	7.43	8.01
	9	135	2.85	3.86	5.16	6.70	8.35	9.14	9.87
	11	135	3.32	4.64	6.39	8.44	10.4	11.2	11.80
	12.5	135	3.60	4.95	6.69	8.77	11.0	12.1	13.1
TGE 20	12.5	135	3.46	4.66	6.30	8.40	10.9	12.1	13.4
	16	135	4.18	5.65	7.69	10.3	13.4	15.0	16.6
	20	135	5.12	6.92	9.31	12.4	15.9	17.8	19.6
	21	135	8.49	11.6	15.2	19.1	22.6	24.0	25.1
TGE 40	26	135	6.80	9.24	12.5	16.7	21.6	24.2	26.8
	30	135	7.63	10.4	14.1	18.9	24.5	27.4	30.3
	40	135	9.16	12.4	16.8	22.9	31.1	35.9	40.7
	42	135	17.2	22.7	29.5	37.1	44.5	47.7	50.3

Subcooling correction factor 'fsub'

Subcooling [K]	2	4	10	15	20	25	30
Correction factor	0.98	1.00	1.06	1.12	1.17	1.22	1.27

Subcooling correction factor 'fsub'

Subcooling [°F]	2	7	10	20	30	40	50
Correction factor	0.97	1.00	1.02	1.08	1.14	1.19	1.25

Distributer correction factor 'fp' *

Pressure drop [bar] Δp	Evaporating temperature [°C]						
	-40	-30	-20	-10	0	10	15
0	1	1	1	1	1	1	1
1	0.96	0.96	0.96	0.95	0.95	0.93	0.92
1.5	0.94	0.94	0.94	0.93	0.92	0.90	0.88
2	0.92	0.92	0.91	0.91	0.89	0.86	0.84

*Calculated at 32 °C condensing temperature.

Distributer correction factor 'fp' *

Pressure drop [psi] Δp	Evaporating temperature [°F]						
	-40	-20	0	20	40	50	60
0	1	1	1	1	1	1	1
15	0.96	0.96	0.96	0.95	0.94	0.93	0.92
25	0.93	0.93	0.93	0.92	0.90	0.88	0.86
30	0.92	0.92	0.91	0.90	0.88	0.86	0.83

*Calculated at 90 °F condensing temperature.



Data sheet | Thermostatic expansion valves, type TGE 10, TGE 20, TGE 40

Capacity in kW. -40 – 15 °C
Opening superheat sh = 4 K

SI units R290

Valve type	Orifice no.	Cond. temp. [°C]	Evaporating temperature [°C]						
			-40	-30	-20	-10	0	10	15
TGE 10	3	25	4.76	5.99	7.27	8.42	9.14	8.85	8.03
	4	25	6.47	8.15	9.90	11.5	12.5	12.1	11.0
	6	25	9.60	12.1	14.7	17.1	18.6	18.0	16.3
	8	25	13.1	16.5	20.0	23.1	25.0	24.0	21.6
	9	25	15.3	19.4	23.6	27.5	29.9	29.0	26.0
	11	25	19.5	24.5	29.5	33.4	35.0	32.5	28.7
	12.5	25	19.9	25.1	30.6	35.8	39.0	38.0	34.3
TGE 20	12.5	25	23.3	29.3	35.6	41.4	45.0	43.7	39.3
	12.5	25	18.5	23.7	29.6	35.4	39.7	39.7	36.5
	16	25	23.2	29.9	37.4	45.0	50.7	50.9	47.0
	20	25	28.7	36.6	45.3	53.7	59.7	58.8	53.6
TGE 40	21	25	36.6	45.9	55.4	63.3	67.1	63.0	55.8
	26	25	39.3	51.2	64.5	78.1	89.0	90.5	83.9
	30	25	44.8	58.4	73.6	89.1	101	103	95.2
	40	25	53.9	70.2	89.3	109	125	125	114
	42	25	72.9	91.5	111	128	136	129	115

Capacity in TR. -40 – 60 °F
Opening superheat sh = 7.2 °F

US units R290

Valve type	Orifice no.	Cond. temp. [°F]	Evaporating temperature [°F]						
			-40	-20	0	20	40	50	60
TGE 10	3	75	1.35	1.74	2.13	2.45	2.55	2.44	2.12
	4	75	1.84	2.37	2.90	3.35	3.49	3.34	2.91
	6	75	2.73	3.52	4.32	4.99	5.19	4.95	4.31
	8	75	3.73	4.79	5.87	6.74	6.96	6.61	5.72
	9	75	4.37	5.63	6.94	8.03	8.37	7.98	6.85
	11	75	5.54	7.12	8.61	9.63	9.59	8.92	7.58
	12.5	75	5.65	7.29	9.02	10.5	11.0	10.5	9.03
TGE 20	12.5	75	6.63	8.51	10.5	12.1	12.6	12.0	10.3
	12.5	75	5.26	6.91	8.76	10.5	11.3	10.9	9.71
	16	75	6.62	8.73	11.1	13.3	14.5	14.1	12.5
	20	75	8.17	10.7	13.4	15.8	16.9	16.2	14.2
TGE 40	21	75	10.4	13.3	16.2	18.3	18.5	17.3	14.7
	26	75	11.2	15.0	19.2	23.3	25.6	25.0	22.3
	30	75	12.8	17.1	21.9	26.5	29.1	28.5	25.3
	40	75	15.4	20.6	26.6	32.6	35.6	34.4	30.1
	42	75	20.7	26.5	32.4	37.0	37.8	35.5	30.3

Capacity in kW. -40 – 15 °C
Opening superheat sh = 4 K

SI units R290

Valve type	Orifice no.	Cond. temp. [°C]	Evaporating temperature [°C]						
			-40	-30	-20	-10	0	10	15
TGE 10	3	35	4.68	5.98	7.40	8.84	10.1	10.8	10.7
	4	35	6.32	8.08	10.0	12.0	13.7	14.7	14.6
	6	35	9.30	11.9	14.8	17.7	20.3	21.6	21.4
	8	35	12.6	16.1	20.0	23.8	27.1	28.7	28.4
	9	35	14.8	19.0	23.6	28.2	32.1	34.1	34.0
	11	35	18.8	24.2	29.8	35.1	38.8	39.6	38.3
	12.5	35	19.0	24.4	30.4	36.5	41.7	44.5	44.3
TGE 20	16	35	22.3	28.5	35.4	42.4	48.3	51.5	51.2
	12.5	35	17.7	23.0	29.2	36.0	42.6	46.9	47.2
	16	35	22.2	28.8	36.7	45.5	54.0	59.8	60.4
	20	35	27.3	35.3	44.5	54.4	63.8	69.6	69.7
TGE 40	21	35	36.4	46.3	56.8	66.7	74.0	76.3	74.6
	26	35	36.8	48.6	62.3	77.6	92.8	104	106
	30	35	41.9	55.3	70.9	88.3	106	118	120
	40	35	50.5	66.5	86.1	109	132	147	148
	42	35	73.3	93.1	115	135	151	157	155

Capacity in TR. -40 – 60 °F
Opening superheat sh = 7.2 °F

US units R290

Valve type	Orifice no.	Cond. temp. [°F]	Evaporating temperature [°F]						
			-40	-20	0	20	40	50	60
TGE 10	3	95	1.33	1.74	2.19	2.64	2.98	3.05	3.02
	4	95	1.79	2.35	2.97	3.59	4.06	4.16	4.12
	6	95	2.64	3.47	4.39	5.30	5.99	6.14	6.07
	8	95	3.57	4.69	5.92	7.12	7.99	8.16	8.02
	9	95	4.21	5.53	7.00	8.42	9.46	9.69	9.62
	11	95	5.33	7.04	8.81	10.4	11.3	11.2	10.8
	12.5	95	5.40	7.10	9.03	10.9	12.3	12.6	12.6
TGE 20	16	95	6.33	8.30	10.5	12.7	14.3	14.6	14.5
	12.5	95	5.03	6.71	8.71	10.9	12.8	13.3	13.4
	16	95	6.29	8.41	11.0	13.8	16.2	17.0	17.1
	20	95	7.76	10.3	13.2	16.4	19.1	19.8	19.7
TGE 40	21	95	10.3	13.5	16.8	19.8	21.5	21.7	21.1
	26	95	10.5	14.2	18.6	23.5	28.0	29.5	30.0
	30	95	11.9	16.2	21.2	26.8	31.8	33.5	34.0
	40	95	14.3	19.4	25.8	33.2	39.9	41.8	41.9
	42	95	20.8	27.1	33.9	40.2	44.2	44.7	43.7

Subcooling correction factor 'fsub'

Subcooling [K]	2	4	10	15	20	25	30
Correction factor	0.98	1.00	1.06	1.11	1.16	1.21	1.26

Subcooling correction factor 'fsub'

Subcooling [°F]	2	7	10	20	30	40	50
Correction factor	0.97	1.00	1.02	1.07	1.13	1.18	1.24

Distributer correction factor 'fp' *

Pressure drop [bar] Δp	Evaporating temperature [°C]						
	-40	-30	-20	-10	0	10	15
	Correction factor						
0	1	1	1	1	1	1	1
1	0.95	0.95	0.94	0.93	0.92	0.89	0.87
1.5	0.92	0.92	0.91	0.90	0.88	0.84	0.79
2	0.90	0.89	0.88	0.86	0.83	0.77	0.71

*Calculated at 32 °C condensing temperature.

Distributer correction factor 'fp' *

Pressure drop [psi] Δp	Evaporating temperature [°F]						
	-40	-20	0	20	40	50	60
	Correction factor						
0	1	1	1	1	1	1	1
15	0.95	0.94	0.94	0.93	0.91	0.89	0.86
25	0.91	0.91	0.90	0.88	0.84	0.81	0.75
30	0.89	0.89	0.87	0.85	0.81	0.77	0.69

*Calculated at 90 °F condensing temperature.



Data sheet | Thermostatic expansion valves, type TGE 10, TGE 20, TGE 40

Capacity in kW. -40 – 15 °C
Opening superheat sh = 4 K

SI units R290

Valve type	Orifice no.	Cond. temp. [°C]	Evaporating temperature [°C]						
			-40	-30	-20	-10	0	10	15
TGE 10	3	45	4.48	5.78	7.25	8.85	10.4	11.7	12.1
	4	45	6.00	7.76	9.76	11.9	14.1	15.9	16.4
	6	45	8.73	11.3	14.3	17.5	20.7	23.2	24.0
	8	45	11.7	15.2	19.2	23.4	27.6	30.8	31.6
	9	45	13.8	18.0	22.7	27.7	32.5	36.2	37.4
	11	45	17.5	23.0	29.0	35.0	40.3	43.4	43.7
	12.5	45	17.5	22.8	29.0	35.7	42.0	46.9	48.5
TGE 20	12.5	45	16.5	21.6	27.7	34.8	42.4	49.2	51.7
	16	45	20.5	26.8	34.5	43.6	53.4	62.3	65.6
	20	45	25.3	32.9	41.9	52.4	63.4	73.2	76.6
	21	45	35.0	45.1	56.3	67.4	76.9	83.0	84.2
TGE 40	26	45	33.5	44.6	57.8	73.3	90.3	107	113
	30	45	37.9	50.6	65.6	83.2	103	121	128
	40	45	45.8	60.8	79.7	103	130	155	163
	42	45	71.5	91.8	115	138	158	172	175

Capacity in TR. -40 – 60 °F
Opening superheat sh = 7.2 °F

US units R290

Valve type	Orifice no.	Cond. temp. [°F]	Evaporating temperature [°F]						
			-40	-20	0	20	40	50	60
TGE 10	3	115	1.26	1.67	2.15	2.66	3.14	3.33	3.46
	4	115	1.69	2.25	2.89	3.59	4.25	4.52	4.70
	6	115	2.46	3.28	4.23	5.26	6.23	6.62	6.87
	8	115	3.30	4.40	5.67	7.02	8.28	8.76	9.06
	9	115	3.88	5.19	6.72	8.31	9.74	10.3	10.7
	11	115	4.91	6.65	8.57	10.5	12.0	12.4	12.5
	12.5	115	4.92	6.60	8.59	10.7	12.6	13.3	13.9
TGE 20	12.5	115	4.65	6.24	8.22	10.5	12.9	14.0	14.8
	16	115	5.76	7.76	10.3	13.2	16.3	17.7	18.8
	20	115	7.10	9.51	12.4	15.8	19.3	20.8	21.9
	21	115	9.89	13.1	16.6	20.1	22.8	23.7	24.1
TGE 40	26	115	9.39	12.9	17.2	22.2	27.6	30.2	32.2
	30	115	10.6	14.6	19.5	25.2	31.4	34.2	36.5
	40	115	12.8	17.6	23.7	31.5	40.1	43.9	46.7
	42	115	20.2	26.7	33.9	41.2	47.1	49.1	50.3

Capacity in kW. -40 – 15 °C
Opening superheat sh = 4 K

SI units R290

Valve type	Orifice no.	Cond. temp. [°C]	Evaporating temperature [°C]						
			-40	-30	-20	-10	0	10	15
TGE 10	3	55	4.16	5.42	6.87	8.49	10.2	11.8	12.5
	4	55	5.54	7.23	9.19	11.4	13.7	15.9	16.8
	6	55	7.97	10.4	13.3	16.5	19.9	23.1	24.4
	8	55	10.6	13.9	17.7	22.0	26.4	30.5	32.2
	9	55	12.4	16.3	21.0	26.1	31.3	35.9	37.9
	11	55	15.7	21.1	27.1	33.4	39.5	44.2	45.5
	12.5	55	15.5	20.5	26.5	33.2	40.1	46.3	48.9
TGE 20	12.5	55	15.0	19.7	25.3	32.2	39.9	47.8	51.3
	16	55	18.5	24.3	31.4	40.0	49.9	60.0	64.7
	20	55	22.7	29.7	38.2	48.2	59.5	71.0	76.1
	21	55	32.6	42.6	53.8	65.4	76.2	84.6	87.6
TGE 40	26	55	29.5	39.6	51.8	66.3	83.1	101	110
	30	55	33.3	44.7	58.6	75.1	94.1	114	124
	40	55	40.3	53.6	70.8	93.0	120	150	163
	42	55	67.8	87.8	111	135	158	177	184

Capacity in TR. -40 – 60 °F
Opening superheat sh = 7.2 °F

US units R290

Valve type	Orifice no.	Cond. temp. [°F]	Evaporating temperature [°F]						
			-40	-20	0	20	40	50	60
TGE 10	3	135	1.16	1.55	2.01	2.53	3.07	3.32	3.54
	4	135	1.54	2.07	2.69	3.40	4.14	4.48	4.78
	6	135	2.21	2.98	3.89	4.93	6.00	6.50	6.94
	8	135	2.93	3.96	5.17	6.54	7.94	8.58	9.11
	9	135	3.39	4.64	6.12	7.76	9.37	10.1	10.8
	11	135	4.34	6.02	7.93	9.94	11.8	12.5	13.0
	12.5	135	4.25	5.81	7.73	9.88	12.0	13.0	13.9
TGE 20	12.5	135	4.16	5.60	7.42	9.62	12.1	13.4	14.5
	16	135	5.11	6.90	9.18	12.0	15.1	16.8	18.3
	20	135	6.28	8.46	11.1	14.4	18.0	19.8	21.5
	21	135	9.06	12.2	15.8	19.4	22.7	24.0	25.0
TGE 40	26	135	8.10	11.3	15.1	19.8	25.3	28.1	30.8
	30	135	9.12	12.7	17.1	22.4	28.6	31.8	34.9
	40	135	11.1	15.2	20.7	28.0	37.0	41.7	46.1
	42	135	18.9	25.3	32.6	40.2	47.2	50.1	52.4

Subcooling correction factor 'fsub'

Subcooling [K]	2	4	10	15	20	25	30
Correction factor	0.98	1.00	1.06	1.11	1.16	1.21	1.26

Subcooling correction factor 'fsub'

Subcooling [°F]	2	7	10	20	30	40	50
Correction factor	0.97	1.00	1.02	1.07	1.13	1.18	1.24

Distributer correction factor 'fp' *

Pressure drop [bar] Δp	Evaporating temperature [°C]						
	-40	-30	-20	-10	0	10	15
	Correction factor						
0	1	1	1	1	1	1	1
1	0.95	0.95	0.94	0.93	0.92	0.89	0.87
1.5	0.92	0.92	0.91	0.90	0.88	0.84	0.79
2	0.90	0.89	0.88	0.86	0.83	0.77	0.71

*Calculated at 32 °C condensing temperature.

Distributer correction factor 'fp' *

Pressure drop [psi] Δp	Evaporating temperature [°F]						
	-40	-20	0	20	40	50	60
	Correction factor						
0	1	1	1	1	1	1	1
15	0.95	0.94	0.94	0.93	0.91	0.89	0.86
25	0.91	0.91	0.90	0.88	0.84	0.81	0.75
30	0.89	0.89	0.87	0.85	0.81	0.77	0.69

*Calculated at 90 °F condensing temperature.



Data sheet | Thermostatic expansion valves, type TGE 10, TGE 20, TGE 40

Dimensions and weights

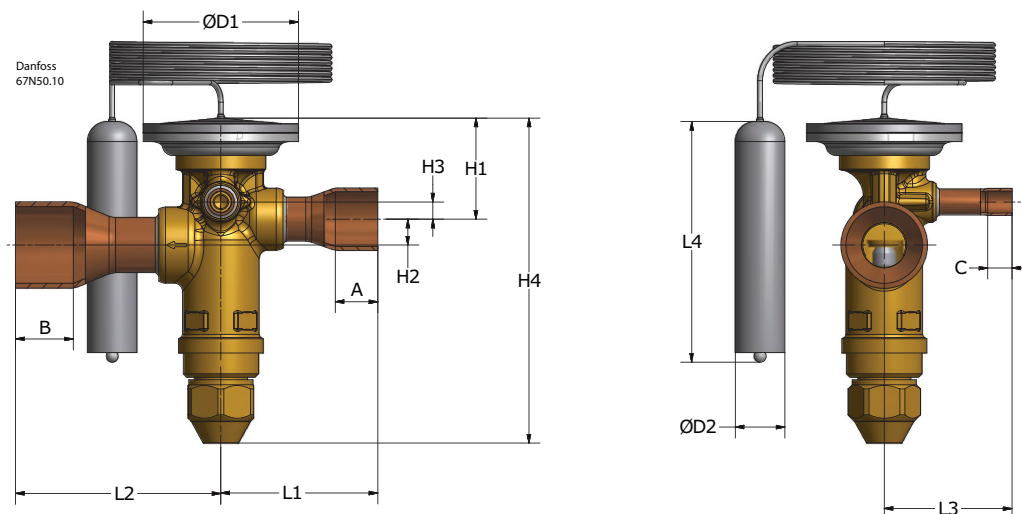

Dimensions and weight in SI units

Type	Connections. ODF solder inlet x outlet x equalization		Capillary tube length [m]	H1 [mm]	H2 [mm]	H3 [mm]	H4 [mm]	L1 [mm]	L2 [mm]	L3 [mm]	L4 [mm]	ØD1 [mm]	ØD2 [mm]	A [mm]	B [mm]	C [mm]	Weight [kg]
	[in.]	[mm]															
TGE 10	3/8 x 3/8 x 1/4	10 x 16 x 6	1.5	28.5	7.5	5.0	93.0	41.5	45.5	37.0	70	45	14.35	9.0	12	7	0.37
	1/2 x 3/8 x 1/4	12 x 16 x 6	1.5	28.5	7.5	5.0	93.0	41.5	45.5	37.0	70	45	14.35	10	12	7	0.37
	1/2 x 7/8 x 1/4	12 x 22 x 6	1.5	28.5	7.5	5.0	93.0	41.5	59.5	37.0	70	45	14.35	10	17	7	0.37
	5/8 x 3/8 x 1/4	16 x 16 x 6	1.5	28.5	7.5	5.0	93.0	45.5	45.5	37.0	70	45	14.35	12	12	7	0.37
	5/8 x 7/8 x 1/4	16 x 22 x 6	1.5	28.5	7.5	5.0	93.0	45.5	59.5	37.0	70	45	14.35	12	17	7	0.37
	3/4 x 1 1/8 x 1/4	16 x 28 x 6	1.5	28.5	7.5	5.0	93.0	45.5	59.5	37.0	70	45	14.35	12	20	7	0.37
	7/8 x 7/8 x 1/4	22 x 22 x 6	1.5	28.5	7.5	5.0	93.0	45.5	59.5	37.0	70	45	14.35	12	17	7	0.37
TGE 20	3/8 x 3/8 x 1/4	16 x 16 x 6	1.5	32.0	9.0	8.0	121	48.0	62.0	40.5	78	53	19.20	12	12	7	0.57
	5/8 x 3/8 x 1/4	16 x 22 x 6	1.5	32.0	9.0	8.0	121	48.0	62.0	40.5	78	53	19.20	12	17	7	0.57
	3/8 x 1 1/8 x 1/4	16 x 28 x 6	1.5	32.0	9.0	8.0	121	48.0	66.0	40.5	78	53	19.20	12	20	7	0.57
	7/8 x 7/8 x 1/4	22 x 22 x 6	1.5	32.0	9.0	8.0	121	62.0	62.0	40.5	78	53	19.20	17	17	7	0.57
	7/8 x 1 1/8 x 1/4	22 x 28 x 6	1.5	32.0	9.0	8.0	121	62.0	66.0	40.5	78	53	19.20	17	20	7	0.57
	7/8 x 1 3/8 x 1/4	22 x 35 x 6	1.5	32.0	9.0	8.0	121	62.0	66.0	40.5	78	53	19.20	17	24	7	0.57
	1 1/8 x 1 1/8 x 1/4	28 x 28 x 6	1.5	32.0	9.0	8.0	121	62.0	66.0	40.5	78	53	19.20	20	20	7	0.57
TGE 40	1 1/8 x 1 3/8 x 1/4	28 x 35 x 6	1.5	32.0	9.0	8.0	121	62.0	66.0	40.5	78	53	19.20	20	24	7	0.57
	7/8 x 7/8 x 1/4	22 x 22 x 6	3	39.0	15	11	148	65.5	69.5	43.5	78	60	19.20	17	20	7	0.93
	7/8 x 1 1/8 x 1/4	22 x 28 x 6	3	39.0	15	11	148	65.5	69.5	43.5	78	60	19.20	17	20	7	0.93
	7/8 x 1 3/8 x 1/4	22 x 35 x 6	3	39.0	15	11	148	65.5	74.5	43.5	78	60	19.20	17	25	7	0.93
TGE 40	1 1/8 x 1 1/8 x 1/4	28 x 28 x 6	3	39.0	15	11	148	69.5	69.5	43.5	78	60	19.20	20	20	7	0.93
	1 1/8 x 1 3/8 x 1/4	28 x 35 x 6	3	39.0	15	11	148	69.5	74.5	43.5	78	60	19.20	20	25	7	0.93

Dimensions and weights

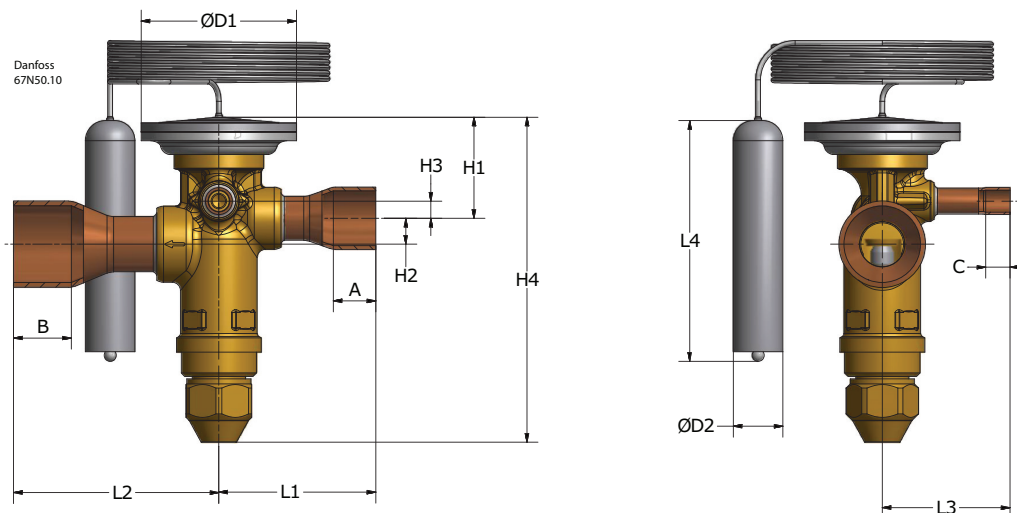

Dimensions and weight in US units

Type	Connections. ODF solder inlet x outlet x equalization		Capillary tube length [in.]	H1 [in.]	H2 [in.]	H3 [in.]	H4 [in.]	L1 [in.]	L2 [in.]	L3 [in.]	L4 [in.]	ØD1 [in.]	ØD2 [in.]	A [in.]	B [in.]	C [in.]	Weight [lbs]
	[in.]	[mm]															
TGE 10	3/8 x 5/8 x 1/4	10 x 16 x 6	59	1.12	0.30	0.20	3.66	1.63	1.79	1.46	2.76	1.77	0.56	0.36	0.48	0.28	0.81
	1/2 x 5/8 x 1/4	12 x 16 x 6	59	1.12	0.30	0.20	3.66	1.63	1.79	1.46	2.76	1.77	0.56	0.39	0.48	0.28	0.81
	1/2 x 7/8 x 1/4	12 x 22 x 6	59	1.12	0.30	0.20	3.66	1.63	2.34	1.46	2.76	1.77	0.56	0.39	0.66	0.28	0.81
	5/8 x 5/8 x 1/4	16 x 16 x 6	59	1.12	0.30	0.20	3.66	1.79	1.79	1.46	2.76	1.77	0.56	0.48	0.48	0.28	0.81
	5/8 x 7/8 x 1/4	16 x 22 x 6	59	1.12	0.30	0.20	3.66	1.79	2.34	1.46	2.76	1.77	0.56	0.48	0.66	0.28	0.81
	5/8 x 1 1/8 x 1/4	16 x 28 x 6	59	1.12	0.30	0.20	3.66	1.79	2.34	1.46	2.76	1.77	0.56	0.48	0.78	0.28	0.81
	7/8 x 7/8 x 1/4	22 x 22 x 6	59	1.12	0.30	0.20	3.66	1.79	2.34	1.46	2.76	1.77	0.56	0.48	0.66	0.28	0.81
TGE 20	7/8 x 1 1/8 x 1/4	22 x 28 x 6	59	1.12	0.30	0.20	3.66	1.79	2.34	1.46	2.76	1.77	0.56	0.48	0.78	0.28	0.81
	5/8 x 5/8 x 1/4	16 x 16 x 6	59	1.26	0.35	0.31	4.76	1.89	2.44	1.59	3.07	2.09	0.76	0.48	0.48	0.28	1.27
	5/8 x 7/8 x 1/4	16 x 22 x 6	59	1.26	0.35	0.31	4.76	1.89	2.44	1.59	3.07	2.09	0.76	0.48	0.66	0.28	1.27
	5/8 x 1 1/8 x 1/4	16 x 28 x 6	59	1.26	0.35	0.31	4.76	1.89	2.6	1.59	3.07	2.09	0.76	0.48	0.78	0.28	1.27
	7/8 x 7/8 x 1/4	22 x 22 x 6	59	1.26	0.35	0.31	4.76	2.44	2.44	1.59	3.07	2.09	0.76	0.66	0.66	0.28	1.27
	7/8 x 1 1/8 x 1/4	22 x 28 x 6	59	1.26	0.35	0.31	4.76	2.44	2.6	1.59	3.07	2.09	0.76	0.66	0.78	0.28	1.27
	7/8 x 1 3/8 x 1/4	22 x 35 x 6	59	1.26	0.35	0.31	4.76	2.44	2.6	1.59	3.07	2.09	0.76	0.66	0.98	0.28	1.27
TGE 40	1 1/8 x 1 1/8 x 1/4	28 x 28 x 6	59	1.26	0.35	0.31	4.76	2.44	2.6	1.59	3.07	2.09	0.76	0.78	0.78	0.28	1.27
	1 1/8 x 1 3/8 x 1/4	28 x 35 x 6	59	1.26	0.35	0.31	4.76	2.44	2.6	1.59	3.07	2.09	0.76	0.78	0.98	0.28	1.27
	7/8 x 7/8 x 1/4	22 x 22 x 6	118	1.54	0.59	0.43	5.83	2.58	2.74	1.71	3.07	2.36	0.76	0.66	0.78	0.28	2.05
	7/8 x 1 1/8 x 1/4	22 x 28 x 6	118	1.54	0.59	0.43	5.83	2.58	2.74	1.71	3.07	2.36	0.76	0.66	0.78	0.28	2.05
	7/8 x 1 3/8 x 1/4	22 x 35 x 6	118	1.54	0.59	0.43	5.83	2.58	2.93	1.71	3.07	2.36	0.76	0.66	0.98	0.28	2.05
TGE 40	1 1/8 x 1 1/8 x 1/4	28 x 28 x 6	118	1.54	0.59	0.43	5.83	2.74	2.74	1.71	3.07	2.36	0.76	0.78	0.78	0.28	2.05
	1 1/8 x 1 3/8 x 1/4	28 x 35 x 6	118	1.54	0.59	0.43	5.83	2.74	2.93	1.71	3.07	2.36	0.76	0.78	0.98	0.28	2.05

Danfoss can accept no responsibility for possible errors in catalogues, brochures and other printed material. Danfoss reserves the right to alter its products without notice. This also applies to products already on order provided that such alterations can be made without consequential changes being necessary in specifications already agreed. All trademarks in this material are property of the respective companies. Danfoss and the Danfoss logotype are trademarks of Danfoss A/S. All rights reserved.