



Compressor
Voltage Code : XC

FH4532Z-XC3A

High Temp. Commercial (HP)

220 - 240V 1~ 50 Hz

R452A / R404A / R448A / R449A

FH4532ZXC3A

Conditions	Frequency	Nominal Cooling Capacity		Sound Power ISO3745 / ISO 3743-1
		Watts	BTU/h	
EN12900 / R452A	50 Hz	6482	22104	74 dBA
EN12900 / R404A	50 Hz	6470	22061	74 dBA
EN12900 / R448A	50 Hz	6492	22139	74 dBA
EN12900 / R449A	50 Hz	6492	22139	74 dBA

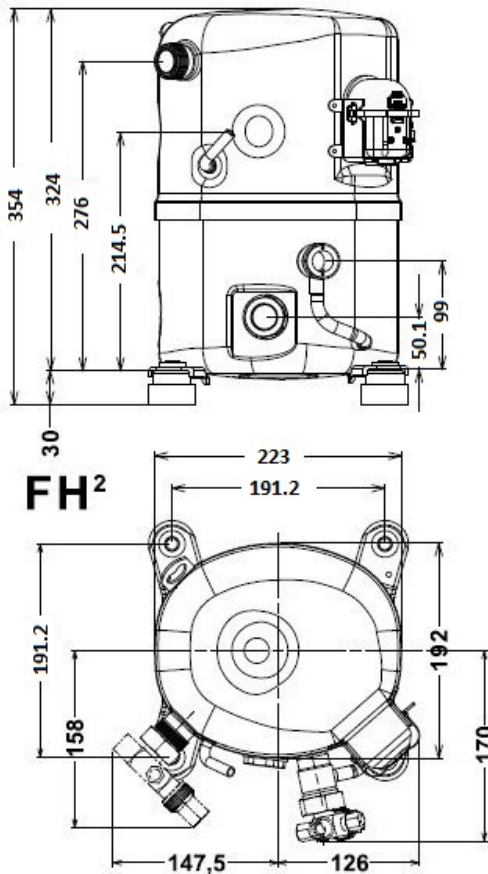

Displacement (cc)	50.6
Net Weight (Kg)	30.0
Oil Quantity (cc)	1140.0
Oil Type	Polyolester
Expansion Device	Capillary_Tube/Expansion_Valve
Cooling	Fan
Main Winding (Ohm)	0.83
Start Winding (Ohm)	2.52
Current	
RLA (A)	12.2
MCC (A)	21.5
LRA (A)	85
Electrical Equipment	CSR
Overload	Interne
Start Capacitor	125 µF / 330 V
Run Capacitor	50 µF / 400 V
Potential Relay	RVA4G**
Pick Up	180/195V
Drop Out	40/105V
Refrigerating connection for OD	
Suction Tube	22.2 (7/8")
Discharge Tube	12.7 (1/2")
Process Tube	6.35 (1/4")

* EN12900 : T°Cond. 50.0°C / T°Evap. 5.0°C / T°Return gas temp.. 20.0°C
T°Subcooling. 0.0K

Certificates :



Note : Tecumseh reserves the right to change information contained in this document without notification.



Tecumseh

FH4532Z-XC3A	Tension XC : 220 - 240V 1~ 50 Hz
---------------------	---

Les performances sont données dans les conditions EN12900 :	Gaz aspirés :	20.0 °C
Condition Dew	Sous refroidissement :	0.0 K
The performance data are in EN12900 conditions :	Return gas :	20.0 °C
Dew Condition	Subcooling :	0.0 K

© 2020 Tecumseh Products Company
All rights reserved

50 Hz R452A

N°User-210

4 T condensation	5 T évaporation	(°C)	-25	-20	-15	-10	-5	0	5	10	15
30	1 P frigorifique	(Watt)	2237	3041	3987	5097	6393	7898	9634	11622	13884
	2 P absorbée	(W)	1288	1436	1555	1651	1729	1793	1848	1899	1950
	3 I absorbée	(A)	5.94	6.57	7.09	7.50	7.80	8.00	8.11	8.13	8.07
40	1 P frigorifique	(Watt)		2365	3202	4166	5279	6563	8041	9735	11666
	2 P absorbée	(W)		1496	1676	1826	1950	2053	2140	2216	2286
	3 I absorbée	(A)		6.85	7.66	8.35	8.93	9.39	9.75	10.0	10.2
50	1 P frigorifique	(Watt)			2440	3260	4192	5259	6482	7884	9486
	2 P absorbée	(W)			1731	1947	2131	2286	2419	2533	2633
	3 I absorbée	(A)			7.90	8.90	9.77	10.5	11.2	11.7	12.1
60	1 P frigorifique	(Watt)				2376	3131	3982	4954	6066	7343
	2 P absorbée	(W)				2004	2260	2481	2672	2837	2982
	3 I absorbée	(A)				9.08	10.3	11.3	12.3	13.1	13.8

50 Hz R404A

N°User-209

4 T condensation	5 T évaporation	(°C)	-25	-20	-15	-10	-5	0	5	10	15
30	1 P frigorifique	(Watt)	2410	3208	4151	5261	6558	8063	9795	11776	14026
	2 P absorbée	(W)	1380	1528	1647	1740	1812	1864	1900	1923	1935
	3 I absorbée	(A)	6.36	7.00	7.51	7.90	8.17	8.31	8.34	8.24	8.02
40	1 P frigorifique	(Watt)	1807	2524	3347	4297	5395	6661	8116	9779	11671
	2 P absorbée	(W)	1389	1597	1773	1919	2040	2138	2215	2275	2321
	3 I absorbée	(A)	6.40	7.32	8.11	8.79	9.34	9.77	10.1	10.3	10.3
50	1 P frigorifique	(Watt)		1854	2561	3355	4258	5289	6470	7819	9358
	2 P absorbée	(W)		1606	1844	2050	2226	2375	2500	2604	2689
	3 I absorbée	(A)		7.34	8.42	9.38	10.2	10.9	11.5	12.0	12.4
60	1 P frigorifique	(Watt)			1790	2433	3144	3945	4855	5895	7085
	2 P absorbée	(W)			1867	2138	2376	2582	2760	2914	3045
	3 I absorbée	(A)			8.43	9.67	10.8	11.8	12.7	13.4	14.1

1 = cooling capacity 2 = power input 3 = current 4 = condensing temperature 5 = evaporating temperature

Nota : Tecumseh se réserve le droit de modifier les informations contenues dans ce document sans préavis.

Note : Tecumseh reserves the right to change information contained in this document without notification.



Tecumseh

FH4532Z-XC3A	Tension XC : 220 - 240V 1~ 50 Hz
---------------------	---

Les performances sont données dans les conditions EN12900 :	Gaz aspirés :	20.0 °C
Condition Dew	Sous refroidissement :	0.0 K
The performance data are in EN12900 conditions :	Return gas :	20.0 °C
Dew Condition	Subcooling :	0.0 K

© 2020 Tecumseh Products Company
All rights reserved

50 Hz R448A (*)

N°User-212

4 T condensation	5 T évaporation	(°C)	-25	-20	-15	-10	-5	0	5	10	15
30	1 P frigorifique	(Watt)	1992	2748	3655	4737	6018	7522	9274	11298	13618
	2 P absorbée	(W)	1215	1348	1460	1552	1626	1683	1725	1753	1769
	3 I absorbée	(A)	5.60	6.17	6.66	7.04	7.33	7.51	7.57	7.51	7.33
40	1 P frigorifique	(Watt)		2175	2979	3925	5038	6341	7858	9615	11634
	2 P absorbée	(W)		1413	1577	1717	1837	1936	2017	2081	2130
	3 I absorbée	(A)		6.48	7.22	7.86	8.41	8.85	9.18	9.40	9.49
50	1 P frigorifique	(Watt)			2322	3140	4092	5201	6492	7989	9717
	2 P absorbée	(W)			1644	1843	2017	2169	2298	2408	2499
	3 I absorbée	(A)			7.50	8.43	9.25	9.98	10.6	11.1	11.5
60	1 P frigorifique	(Watt)				2391	3190	4114	5186	6432	7875
	2 P absorbée	(W)				1923	2163	2376	2564	2730	2873
	3 I absorbée	(A)				8.70	9.83	10.9	11.8	12.6	13.3

50 Hz R449A (*)

N°User-211

4 T condensation	5 T évaporation	(°C)	-25	-20	-15	-10	-5	0	5	10	15
30	1 P frigorifique	(Watt)	1992	2748	3655	4737	6018	7522	9274	11298	13618
	2 P absorbée	(W)	1215	1348	1460	1552	1626	1683	1725	1753	1769
	3 I absorbée	(A)	5.60	6.17	6.66	7.04	7.33	7.51	7.57	7.51	7.33
40	1 P frigorifique	(Watt)		2175	2979	3925	5038	6341	7858	9615	11634
	2 P absorbée	(W)		1413	1577	1717	1837	1936	2017	2081	2130
	3 I absorbée	(A)		6.48	7.22	7.86	8.41	8.85	9.18	9.40	9.49
50	1 P frigorifique	(Watt)			2322	3140	4092	5201	6492	7989	9717
	2 P absorbée	(W)			1644	1843	2017	2169	2298	2408	2499
	3 I absorbée	(A)			7.50	8.43	9.25	9.98	10.6	11.1	11.5
60	1 P frigorifique	(Watt)				2391	3190	4114	5186	6432	7875
	2 P absorbée	(W)				1923	2163	2376	2564	2730	2873
	3 I absorbée	(A)				8.70	9.83	10.9	11.8	12.6	13.3

1 = cooling capacity 2 = power input 3 = current 4 = condensing temperature 5 = evaporating temperature

(*) Veuillez vous référer strictement aux Recommandations d'Utilisation et Bulletins Marketing Tecumseh du fait de la température de reflux élevée pour les applications LBP.

(*) Due to very high discharge temperature especially on LBP conditions, please strictly refer to Tecumseh Guidelines & Marketing Bulletin when using this refrigerant.

Nota : Tecumseh se réserve le droit de modifier les informations contenues dans ce document sans préavis.

Note : Tecumseh reserves the right to change information contained in this document without notification.